

Park Royal Intensification  
Final Report

# Hawkins\Brown

XXXXXXXXXXXXXXXXXXXX

WE MADE THAT

XXXXXXXXXXXXXXXXXXXX



**Hawkins\Brown**

Hawkins\Brown  
159 Saint John Street,  
London EC1V 4QJ

+44 (0) 020 7336 8030  
[www.hawkinsbrown.com](http://www.hawkinsbrown.com)

XXXXXXXXXXXXXXXXXXXX  
WE MADE THAT  
XXXXXXXXXXXXXXXXXXXX

We Made That  
Unit 21 Tower Workshops  
58 Riley Road  
London SE1 3DG

+44 (0)20 7249 6336  
[www.wemadethat.co.uk](http://www.wemadethat.co.uk)

 CUSHMAN &  
WAKEFIELD

Cushman & Wakefield  
125 Old Broad Street,  
London, EC2N 1AR

+44 (0)20 3296 3000  
[cushmanwakefield.co.uk](http://cushmanwakefield.co.uk)

**regeneris**  
ECONOMICS · RESEARCH · ANALYSIS

Regeneris  
3rd Floor  
65 St John's Street  
London  
EC1M 4AN  
0207 336 6188  
<http://www.regeneris.co.uk/>

# Contents

Section A - Context			Appendices		
1 Introduction	9		A Identifier Maps and Sites	1	
1.1 Purpose of this Document			A.1 Site Identification		
1.2 Evidence Base			A.2 Sites		
1.3 Methodology					
2 Context	13		B Long List	21	
2.1 Urban Fabric			B.1 Locations		
2.2 Businesses			B.2 Site Comments		
2.3 Market			B.3 Sites by Site Type		
2.4 Spatial Policy			B.4 Sites by Intensification Type		
2.4 Future Business Growth			B.5 Sites		
Section B Intensification Strategy and Principles			C Case Studies	21	
3 Intensification	33		C.1 Gorst Road Higher Development Capacity Option		
3.1 Intensification Strategy			C.2 Waxlow Road Higher Development Capacity Option		
3.2 Intensification Types			C.3 North Acton Road Higher Development Capacity Option		
3.3 Site Identification			C.4 (7-11) Minerva Road Higher Development Capacity Option		
4 Typologies	47		C.5 Origin Business Park Higher Development Capacity Option		
4.1 Design Principles			C.6 Bashley Road Comprehensive Development Options		
4.2 Case Studies			C.7 Site Identification Criteria		
4.3 Stakeholder Consultation Summary					
4.4 Viability Methodology			D Accommodation Schedule	79	
4.3 Viability Summary			C.1 Accommodation Schedule		
Section C Conclusions			E Typological Design Considerations	81	
5 Jobs	95		E.1 Typologies		
5.1 Methodology for Additional Employment Capacity Calculation					
5.2 Locations and Additional Employment Capacity			F Viability Appraisal Assumptions	83	
6 Delivery	105		F.1 Costs and Values		
6.1 Areas of Focus					
6.2 Recommended Next Steps					

# Executive Summary

# Executive Summary

This study develops typologies to intensify the designated strategic industrial location (SIL) across Park Royal. This work is directed towards two aims: to develop designs that are deliverable and commercially viable, and to provide a robust analysis of the likely uplift in floorspace and employment densities that this could achieve across Park Royal.

The study provides OPDC with appropriate tools to encourage the intensification of industrial land across Park Royal.

## Evidence Base

The study builds upon previous pieces of work that demonstrate the economic imperative to intensify industrial land across Park Royal and details the existing businesses and spatial conditions in Park Royal. This study examines in further detail the potential for increasing the floorspace and employment capacity of Park Royal, including scope for the estimated 4,000-4,500 new jobs identified in the Industrial Land Review.

The emerging industrial sectors appropriate to Park Royal are specified in the Future Employment Growth Sectors study, and this study uses these findings to understand the future spatial requirements of occupiers and their associated employment densities.

## Methodology

The methodology of this study involves two key work streams focussing on site assessment and the second is employment capacity. Stakeholder engagement was also a key part of considering design approaches/issues.

## Context

Existing strengths of the study area are:

- SIL Designation
- Location - Transport , Access to markets
- Established Clusters
- Spatial Diversity

The study area encompasses the western portion of OPDC's boundary, which is designated as SIL. This designation sets the long term imperative to intensify here, where intensification can give long-term benefits to Park Royal, OPDC and London at large.

It is estimated that the local economy employs 43,100 people across around 1,700 businesses, with the majority of activity currently located within Park Royal. The area has experienced growth in recent years both in the number of jobs and number of businesses.

The local economy area is noticeable for the structure of its business base: while the majority of businesses are micro sized (with around three-quarters of businesses employing between 0 and 4 people), this proportion is low when compared to other areas. Reflecting the nature of the area, there is a comparatively strong concentration of larger businesses in the area.

The local economy is currently focused around industrial sectors and activities. Analysis of latest employment data shows that the largest sectors in the OPDC area are wholesale (7,300 jobs), ICT, Media and Creative activities (6,700 jobs), public administration, education and health (6,400 jobs), retail (5,600 jobs), and business support services (5,900 jobs). Combined these five sectors account for 61% of all employment in the OPDC area.

Vacancy rates in Park Royal are very low. As such, large plots of land for new intensive development are few. Therefore strategies for delivering large industrial intensification projects in Park Royal need to be driven by delivery/phasing, looking to incentivise comprehensive re-development in Park Royal to deliver significant uplift in job numbers and floorspace.

Compared to other London industrial

estates, parts of Park Royal achieve very high employment densities, particularly areas of dense light industrial fabric.

The area is characterised by high demand for industrial space (including B1a, B2 and B8), but with limited supply of land for development as well as built space across all sizes and grades. Investors perceive Park Royal to be a strong location to invest in property due to its ability to attract good quality tenants.

Opportunities coming to the market are very scarce, but those opportunities that do come to the market are achieving values that are very high compared to other industrial locations in Greater London. There is particularly high demand for sites (with / without buildings) from owner occupiers.

Developers generally deliver larger units which tend to have lower management requirements. Smaller multi-let developments and Industrial / B1c workshop space with shared facilities are uncommon currently.

Park Royal has access to good transport links, including the A40 and A406 and other wider strategic assets (Heathrow), and access to the London market. Park Royal's position will ensure its continued attractiveness and mean that it remain

# Executive Summary

as a prominent industrial location over the longer term. As this is the case, opportunities for intensification arise from demand associated with Park Royal's location.

Growth in Park Royal is likely to be based around existing strengths listed above. Potential for economic intensification is greatest within the food and other manufacturing sectors as these deliver stronger employment densities than logistics and distribution.

## Intensification

Key drivers for intensification are:

- Protection of SIL Attracting the investment that will deliver intensification relies on protecting the area's SIL designation in the long term.
- Employment Density Multi-storey typologies can create significant increase in employment densities and accommodate a mixture of unit sizes for varying activities. There is an opportunity to exploit sites with good PTAL to increase density.
- Viability Higher average industrial rents and more favourable yields alongside current construction cost levels mean industrial is a viable use to deliver. Park Royal is not currently a recognised office location and rents achievable for new space are low relative to the cost of constructing new space.

- Place Architectural and urban approaches need to be developed to mitigate the impacts of higher density employment in Park Royal and improve the urban environment in order to make it attractive for a wider variety of occupiers.

## Design Principles

The intensification of industrial fabric requires new approaches to design, both at the individual site level and at the urban scale. This will intensify, create value and encourage development in Park Royal.

### Intensify

Creating a more intensive use of land in Park Royal can be achieved through stacking industrial building types into multi-storey developments. Sharing facilities wherever possible also provides incentives for businesses to work in closer proximity, and liberating space for further development.

### Create Value

Incorporating a wider variety of space types/ typologies to align with market demand can ensure the value of this space is maximised.

Separating access for different space types, exploiting high transport accessibility and creating better places can all ensure that the value is created to

incentivise intensification.

## Encourage

Overcoming the inertia to redevelopment of sites can be encouraged through phased redevelopment.

## Case Studies

Designs for intensive industrial typologies are developed for the following sites:

- Willen Field Road (New Provision on Vacant Plot)
- Gorst Road (Comprehensive Redevelopment)
- Waxlow Road (Horizontal Extension)
- North Acton Road (Horizontal Extension)
- Victoria Road (Vertical Extension/Infill)
- Minerva Road (Phased Comprehensive Redevelopment)
- Bashley Road (New Build on Vacant Land)
- Origin Business Park (Internal Subdivision)

## Stakeholder Consultations

Feedback on the design approaches from stakeholders focussed on demand, design, operation and management.

Stakeholders provided strong support for the potential to share facilities, particularly service yards, a diverse range of unit sizes and considered multi-storey typologies to

be attractive for occupiers.

It was thought intensification should also lead to an improved urban environment, with better access to green spaces, better cycle accessibility and connections to public transport. However, further congestion needs to be avoided.

## Viability

A number of the typologies developed proved to be viable. The study has established that viability can be reduced where:

- proposals include multi storey buildings, in particular where the following are required:
  1. Lifts
  2. Vehicle ramps
  3. Concrete frame buildings
- Sites have higher existing use values on a per acre basis make achieving viability more challenging.
- Proposals include a significant element of office space as values achievable are currently at levels which are low relative to the cost of construction. Opportunities exist to create value where limited office space is provided alongside industrial development, including as part of refurbishment of existing space.

# Executive Summary

## Jobs

Based on the design approaches developed in this study, future employment capacity of Park Royal could create an additional 5,100-7,900 jobs.

Place	Low Estimate	High Estimate
Park Royal	3,750 jobs	5,550 jobs
Old Park Royal	1,350 jobs	2,350 jobs
Total	5,100 jobs	7,900 jobs

Suitable intensification sites have a broad spread across Park Royal, reflecting the spatial diversity of the case study sites. Multiple sites in close proximity are identified along Abbey Road, Willen Field Road, Standard Road, Minerva Road and Chase Road.

Larger sites generate a significant part of the overall additional job and floorspace capacity in Park Royal. This is because their size and proportion is typical to the grain of Park Royal, and the size of site allows a compact mix of both industrial and ancillary office uses on a single site.

Design approaches with a higher proportion of B1 uses over a multi-storey building creates a very high density of employment within a single site, although

these sites are less typical in Park Royal.

## Delivery

Intensive development of this type, however, is currently not happening in Park Royal. Potential reasons for this are:

- Lack of sites
- Management risks
- Decant of existing businesses challenging

The most viable intensification strategies under current market conditions are:

- New provision on vacant land
- Partial refurbishment and infill
- Comprehensive redevelopment

The typologies that deliver the largest increase in additional employment and floorspace capacity suggests that a focus of industrial intensification strategies should be on multi-storey industrial typologies that allow access for smaller delivery vehicles to first floor level.

Clustering of intensification sites present an opportunity for strategic planning that mitigates the potential congestion associated with higher employment densities and creates business ecologies that are more than the sum of their parts.

## Recommended Next Steps

The results of the viability testing of designs, the potential for additional floorspace and employment capacity each typology could achieve, and stakeholder consultations define where further steps would encourage the delivery of an intensive industrial area at Park Royal:

### Set the Standard

- A Park Royal Design Guide would assist planning officers in encouraging ambitious proposals.
- An exemplar development would trigger further development.
- Further engagement with developers who have the capacity to deliver new typologies.
- A business Support Programme could provide advice and coordination on implementing sharing of facilities between new and future occupiers.

### Address Impact

- Planning mechanisms should protect SIL and control the location and quantum of office space in Park Royal.
- Public transport accessibility should be improved to ease pressure on existing infrastructure and accommodate higher densities.
- A pilot project on an area of Park Royal should explore how deliveries, car parking and access can be coordinated

between business to make more efficient use of space and infrastructure.

- Social infrastructure, amenity space and the public realm should be improved to attract new occupiers to Park Royal.

### Maximise Value

- Updates to the Infrastructure Delivery Plan should be considered to provide a site-wide strategy to locate key projects.
- Improvements to parks, the canal and key pedestrian routes could be part funded by business rates achievable as a result of intensification.

### Promote

- Promote the findings of this report both within the existing Park Royal business community and beyond.
- Facilitate collaboration and joint ventures between developers, occupiers and workspace providers
- Encourage business or sector specific representatives to coordinate collaborative initiatives.
- Investigate how OPDC and private developers could create space for decant of businesses within or near Park Royal to enable comprehensive redevelopment of sites.
- Continue to monitor demand and supply of space over time to ensure intensification is managed flexibly.

# Section A: Context

## 1 Introduction

The changing economic and spatial context in London is putting new demands on the city's industrial areas.

1.1 Purpose of this Document

1.2 Evidence Base

1.3 Methodology

# 1 Introduction

## 1.1 Purpose of this Document

This study develops typologies to intensify the designated strategic industrial location (SIL) across Park Royal. This work is directed towards two aims: to develop designs that are deliverable and commercially viable, and to provide a robust analysis of the likely uplift in employment densities that this could achieve across Park Royal.

### OPDC Context

The study provides OPDC with appropriate tools to encourage the intensification of industrial land across Park Royal. Reflecting the relative lack of land under OPDC ownership within Park Royal compared to OPDC as a whole this will take two forms: a means to approach landowners with strategies to increase the return on their assets, and through the planning process itself.

It is recognised in general that landowners in Park Royal are not always pro-active in increasing returns through unconventional forms of development and alternative site management, and that this study provides the evidence that this is both commercially viable and feasible in terms of a design approach.

The study provides tools to encourage ambitious proposals from landowners

The report is part of a suite of studies that inform the OPDC's Local Plan.

### GLA Context

The GLA has completed studies into current trends in the supply of industrial land across London, and is currently undertaking a study into demand.

Two scenarios are being developed for the purposes of this demand study, one examining alternative options for locating SIL uses and a second looking at strategies for intensification of existing industrial land within London.

The Park Royal Intensification study fits into this second scenario. Although at a city-wide level this intensification could include the mixing of industrial space with residential uses as a means of intensification, the designation of Park Royal as SIL dictates that intensification in the context of this study will only consider the mixing of industrial and other ancillary/related employment uses. .

A key question emerging from this work is what size, type and mix of industrial units is appropriate to intensify from a commercial, spatial and practical perspective.



# 1 Introduction

## 1.2 Evidence Base

### Industrial Land and Supply Study (2015)

The GLA's Industrial Land and Supply Study examines the pressures on industrial land across London, providing an overview of rates of loss of industrial land, vacancy rates, land values and jobs.

Key findings suggest the release of industrial land must be accompanied with adequate protection and intensification of industrial land across London. Little evidence suggests employment densities in industrial areas are increasing.

### Park Royal Atlas (2014)

The Atlas provides a detailed study of the typologies, clusters of specific industries and spatial characteristics of industrial space across Park Royal.

This granular study reveals the diversity and complexity of the industrial make-up of Park Royal, and a broad confidence amongst its businesses for future growth. The Atlas provides a useful methodology for analysing the physical and industrial make-up of Park Royal, and this methodology will be used in this study.

### Industrial Land Review (2016)

OPDC's ILR offers a high level analysis of potential for intensification in Park Royal. This covers market profile and demand, benchmark plot ratios and employment densities. The ILR identifies that 4,000-

4,500 new jobs (see page 66) could be accommodated within the study area through incremental growth and ad-hoc site development.

The ILR's findings suggest that additional employment generating floor space will need to come from more intensive use of existing sites.

### Future Employment Growth Sectors Study (2017)

The emerging industrial sectors appropriate to Park Royal are specified in OPDC's Future Employment Growth Sectors study. The study specifies the spatial needs and appropriate locations in Park Royal for these sectors, and their associated employment densities.

### Industrial Estates Study (2016)

The study benchmarks Park Royal in relation to other UK estates, and highlights how Park Royal can build upon its competitive position.

Park Royal's current employment density is relatively high, and the study suggests that intensification should identify appropriate sectors and locations for increased density. This study also highlights a diversity of unit sizes that is required to make the area attractive, competitive and affordable to growing sectors.

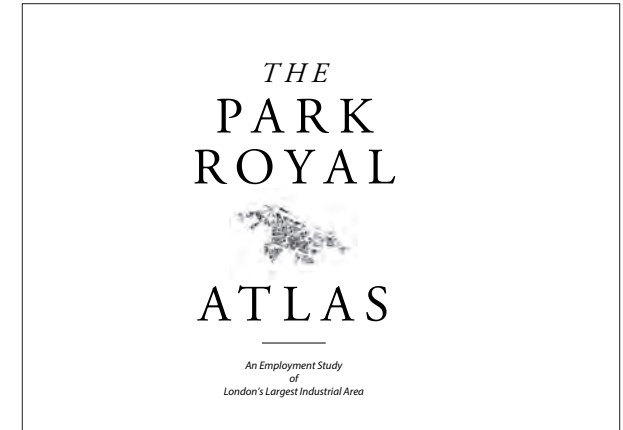

# 1 Introduction

## 1.3 Methodology

### Approach

We have used a methodology that builds upon existing reliable, recognised datasets that cover the physical and economic makeup of Park Royal.

The method is replicable in order to be a robust justification for our conclusions, and allowing it to be used and updated in the future should updated datasets become available or market conditions change.

The methodology involves two key work streams focussing on site assessment and the second is employment capacity. Stakeholder engagement was also a key part of considering design approaches/ issues. Individual components/steps were set out as part of the following work flow and report structure:

### Context

Assessment of the spatial and economic conditions in Park Royal to understand where and how intensification should be focussed.

### Intensification Strategy

Based on the specific conditions in Park Royal, a strategic approach to intensifying which sites types are most appropriate for intensification is developed.

### Indicators

Data-driven approach to identify sites that are suitable for intensification, using data gathered through previous studies.

### Case Studies

Prototypical sites which are most likely to be bought forward in the short term are developed as design exercises to assess the increase in employment density and floorspace capacity that could be achieved on this type of site.

### Viable Case Studies

Viability Assessments are carried out on designs developed for case study sites to determine which sites and designs could potentially be viable in current market conditions. Only viable proposals are included in main body of report

### Intensification Sites

All case studies are used to assess sites across Park Royal which could accommodate similar design approaches.

### Stakeholder Engagement

Viable case studies are consulted on with key stakeholders to encourage their adoption into future developments.

### Additional Employment Capacity

Capacity of the intensification sites is assessed to determine additional employment capacity across Park Royal.

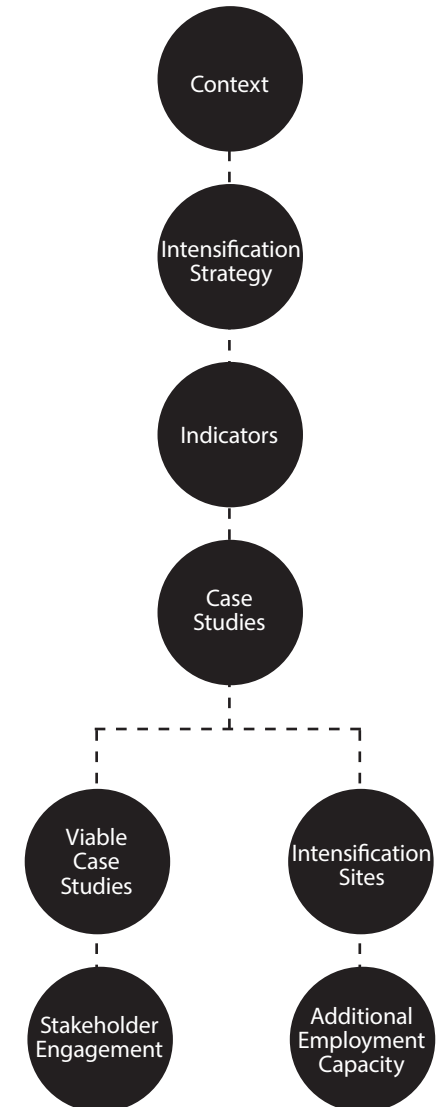

This section describes both the current condition of Park Royal's urban fabric and its ecology of businesses, and how Park Royal is anticipated to change spatially and economically over the course of the next local plan.

2.1 Urban Fabric

2.2 Businesses

2.3 Market

2.4 Spatial Policy

2.5 Future Business Growth

## 2 Context

### 2.1 Urban Fabric

#### 2.1.1 A Strategic Position

##### Park Royal Intensification Study Area

The study area encompasses the western portion of OPDC's boundary, which is designated as SIL. This designation sets the long term imperative to intensify here, providing the market context in which alternative forms of industrial development are most likely to be viable, and where intensification can give long-term benefits to Park Royal, OPDC and London at large.

##### Access to Markets

Park Royal is positioned at a key location with good access to infrastructure assets (A406, A40, the M4 Corridor, M25 and Heathrow) and large markets in West and Central London.

The Industrial Estates Study identifies this position as a key strength that will likely ensure Park Royal will remain as a prominent industrial location in London over the long term.

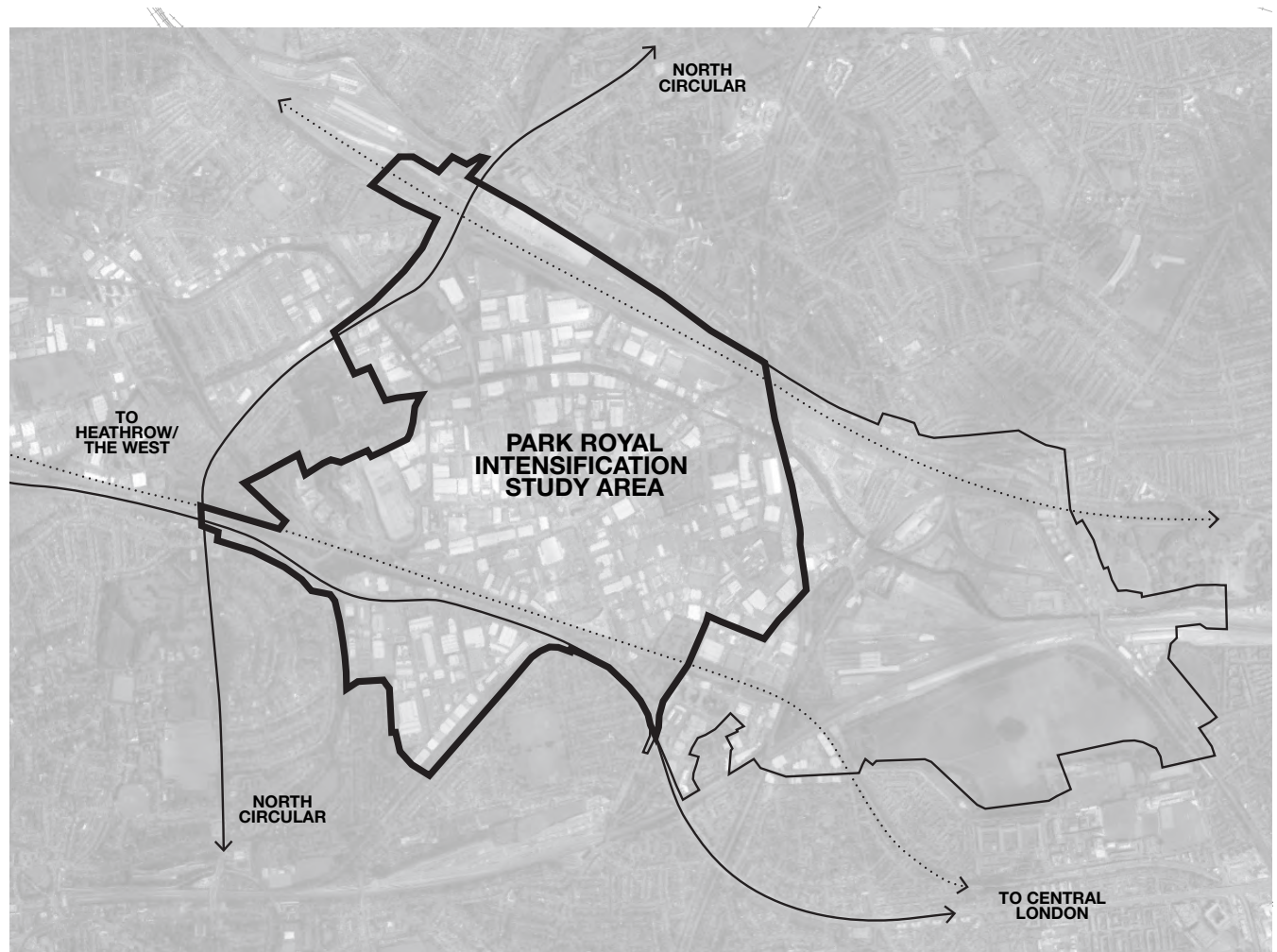
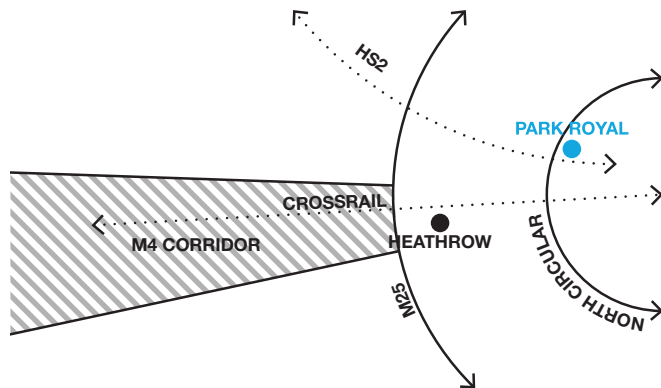

## 2 Context

### 2.1 Urban Fabric

#### 2.1.1 A Strategic Position

##### Strategic Industrial Location

A key strength of Park Royal today is its designation as a strategic industrial location, which defines uses that are appropriate for this area.

Industry and related uses contains the following:

1. Light industrial
2. General industry
3. Logistics, warehousing and storage
4. Waste management and recycling
5. Utilities including energy and water management
6. Land for public transport functions
7. Wholesale markets
8. Some creative industries
9. Other industrial related uses not in 1-8 above

Park Royal is characterised by predominantly industrial which includes light industrial/workshop (B1c) general industrial/manufacturing (B2), and storage and distribution (B8).

These uses tend to generate different employment densities. Office space generally produces the highest employment density whilst B8 industrial produces the lowest.



Business Office  
B1a  
8-13 sqm per employee



Light Industrial  
B1c  
47 sqm per employee



General Industrial  
B2  
36 sqm per employee



Storage or Distribution  
B8  
70-95 sqm per employee

## 2 Context

### 2.1 Urban Fabric

#### 2.1.2 Infrastructure and Places

##### Places

Park Royal is constituted by a number of places of very different character, each undergoing change at differing rates and driven by different dynamics. The study area is comprised of four places identified in the Local Plan. Park Royal (1) forms the majority of the area and is characterised by a mix of industrial fabric. Park Royal Centre (2) contains non-SIL land and include a mix of mainly town centre uses around the Central Middlesex Hospital. Old Park Royal (3) is characterised by older, denser industrial fabric and a closer urban grain. The final place is the Grand Union Canal which extends to the west into the Old Oak Common development area.

##### Infrastructure

Park Royal is served by the A40 and North Circular, and six train stations around its perimeter.

Whilst it is recognised that a significant increase in employment densities in Park Royal would require infrastructural investment, the requirements and costs of this are being addressed in other studies and have not been included in this study.

##### Key

- Places
- Study Area Sites
- Key Routes
- Borough Boundaries
- Key Centres

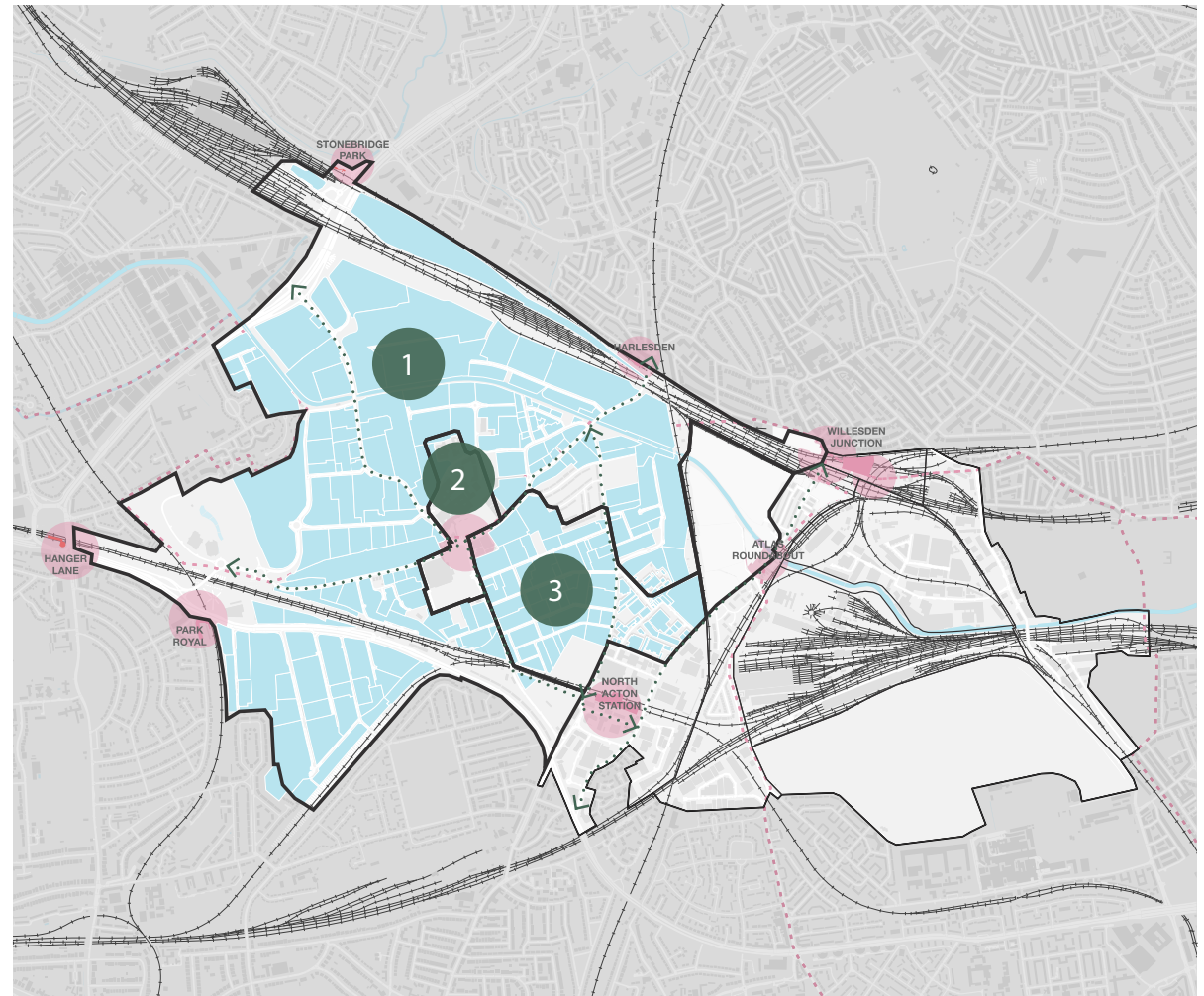

## 2 Context

### 2.1 Urban Fabric

#### 2.1.3 Building Types

The most common space type in Park Royal is small office, making up 30% of spaces. However, due to their larger size warehousing makes up the majority of total built space.

Non-warehouse space is concentrated in the older fabric around Old Park Royal.

Categorised based on Park Royal Atlas workspace categorisation.

#### Key

- Small office
- Large office
- Retail
- Workshop
- Small warehouse
- Large warehouse
- Other
- Study area boundary



## 2 Context

### 2.1 Urban Fabric

#### 2.1.4 Site Types

The site typologies in Park Royal reflects the high density of the estate and the high level of activity in warehousing and transport. The Industrial Estates Study identifies that Park Royal has the largest proportion of dense industrial employment sites amongst all the case study sites (21%).

This density suggest that intensification will need to be incremental, reflecting the lack of vacant and under-utilised land.

- Standalone warehouse
- Industrial estate
- Dense light industrial
- Open industrial land
- Large utilities site / bespoke premises
- Retail park / large retail warehouse
- Business centre
- High street type
- Hotel or standalone office building
- Businesses in primarily residential area
- Other
- Vacant lot
- Study area boundary

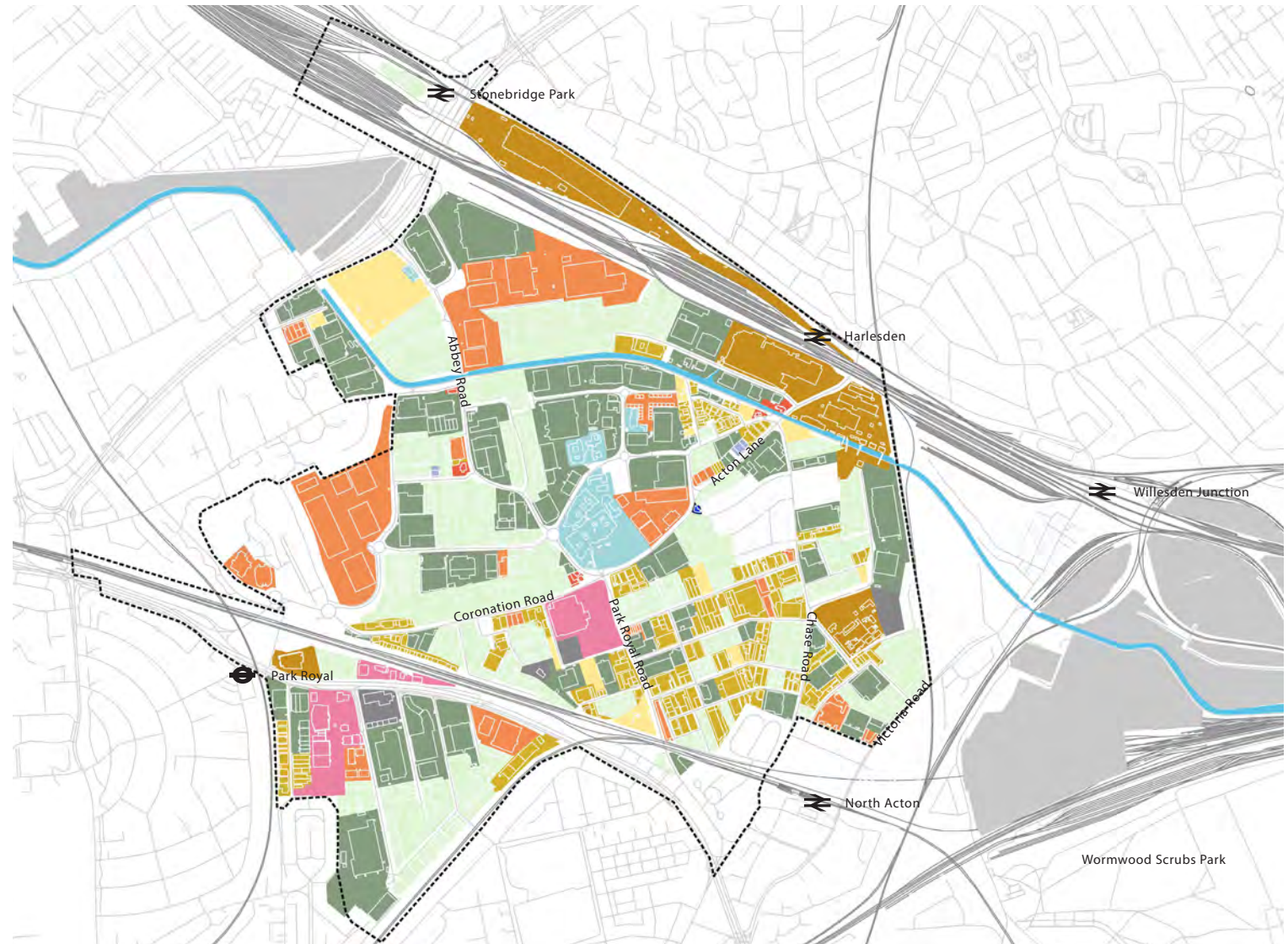

## 2 Context

### 2.1 Urban Fabric

#### 2.1.5 Existing Strengths

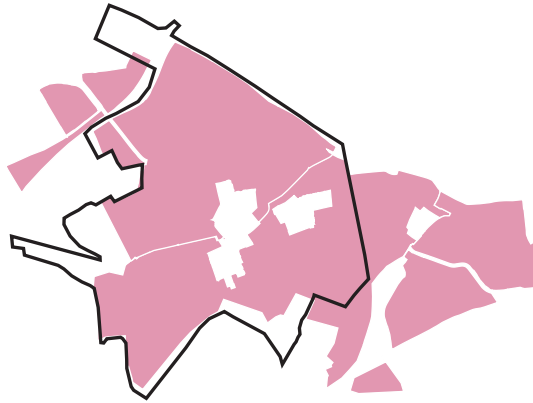

##### SIL Designation

Park Royal's SIL designation is one of its key strengths. Although the intensification of Park Royal will bring about significant change, it should also consolidate and protect the area's industrial capacity.

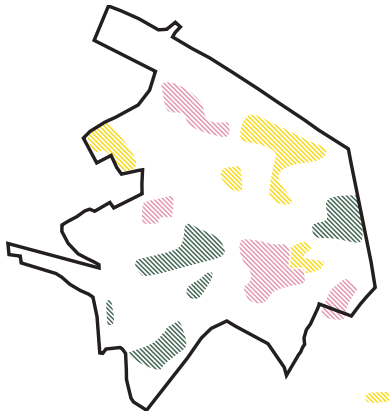

##### Established Clusters

Industries with a high propensity to cluster already exist in Park Royal. The dynamic of clustering companies can play an important role in driving intensification.

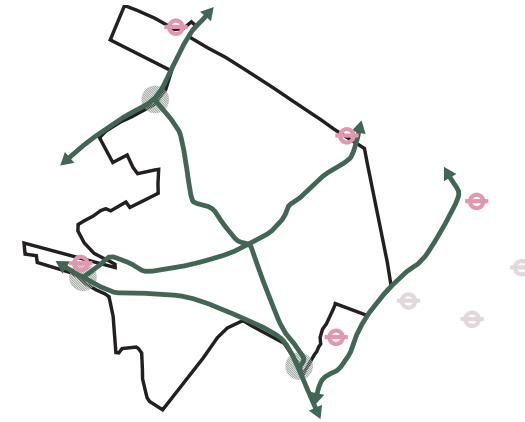

##### Transport Infrastructure

Park Royal has very good access to transport infrastructure for bringing in goods and people. The significant uplift in employment density should not compromise this, and should where possible improve efficiency.

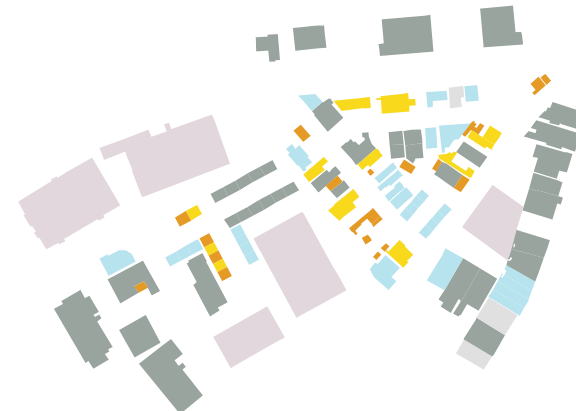

##### Spatial Diversity

A wide mix of unit sizes in Park Royal creates a vibrant economy, allowing a variety of interconnected businesses to form, grow and remain in the area.

## 2 Context

### 2.2 Businesses

#### 2.2.1 Clustering by business activity

The existing business sectors in Park Royal have varying incentives to intensify. Some clusters form due to specific spatial needs (logistics, storage and wholesale), others have a high propensity to cluster due to positive agglomeration effects (such as some services).

Mapped through SIC code classification and business sector as assigned in ILR.

Key

- Manufacturing: food-related
- Manufacturing: metal-related
- Manufacturing: reproduction
- Manufacturing: other
- Utilities
- Construction
- Vehicle Sale & Repair
- Wholesale: food
- Wholesale: other
- Transport & Storage
- Info & Comms
- Services: professional
- Services: other
- Public services
- Retail, Restaurants, Hotels
- Other
- Vacant
- Unknown

..... Study area boundary



## 2 Context

### 2.2 Businesses

#### 2.2.1 Economic Profile

OPDC's Future Employment Growth Sector Study provides a summary of the characteristics and recent performance of the Old Oak and Park Royal economy.

It is estimated that the local economy employs 43,100 people across around 1,700 businesses, with the majority of activity currently located within Park Royal. The area has experienced strong growth in recent years: employment has increased by 19% (8,300 jobs) since 2009, while the business base has grown by 18% (350 businesses) over the same period.

The local economy area is noticeable for the structure of its business base: while the majority of businesses are micro sized (with around three-quarters of businesses employing between 0 and 4 people), this proportion is low when compared to other areas. Reflecting the nature of the area, there is a comparatively strong concentration of larger businesses in the area.

The local economy is currently focused around industrial sectors and activities. Analysis of latest employment data shows that the largest sectors in the OPDC area are wholesale (7,300 jobs), ICT, Media and Creative activities (6,700 jobs), public administration, education and health (6,400 jobs), retail (5,600 jobs), and

business support services (5,900 jobs). Combined these five sectors account for 61% of all employment in the area.

However, in terms of levels of relative specialisation, the most important sectors in the OPDC area are food manufacturing (4,400 jobs and LQ<sup>1</sup> of 13.5), transport (2,500 jobs and LQ of 1.3), wholesale (7,300 jobs and LQ of 4.2), warehousing (3,100 jobs and LQ of 5.8), business support services (5,900 jobs and LQ of 1.1) and ICT, Media and Creative Services (6,700 jobs and LQ of 1.2).

<sup>1</sup> LQ – Location Quotient measure the concentration of employment activity. A value of more than one indicates that activity is more concentrated in the OPDC area than in London; lower than one denotes a lower than average concentration of activity.

## 2 Context

### 2.2 Businesses

#### 2.2.2 Vacancy

Vacancy levels in Park Royal are average compared to other similar estates studied in the Industrial Estate Study, reflecting the pressure on industrial land supply in London. Brent and Ealing have relatively low vacancy rates compared to other London boroughs.

As such, large plots of land for new intensive development are few. Therefore strategies for delivering large industrial intensification projects in Park Royal need to be driven by delivery/phasing, looking to incentivise comprehensive re-development in Park Royal to deliver significant uplift in job numbers.

# 1.9%

Vacancy rate, Brent

# 3.3%

Vacancy rate, Ealing

Source: London Industrial Land Supply & Economy 2015 (AECOM, Cushman & Wakefield, We Made That)

■ Vacant in Park Royal Atlas (2014)  
 ■ No longer vacant based on site observations

Source: Updated from Park Royal Atlas, GLA 2014

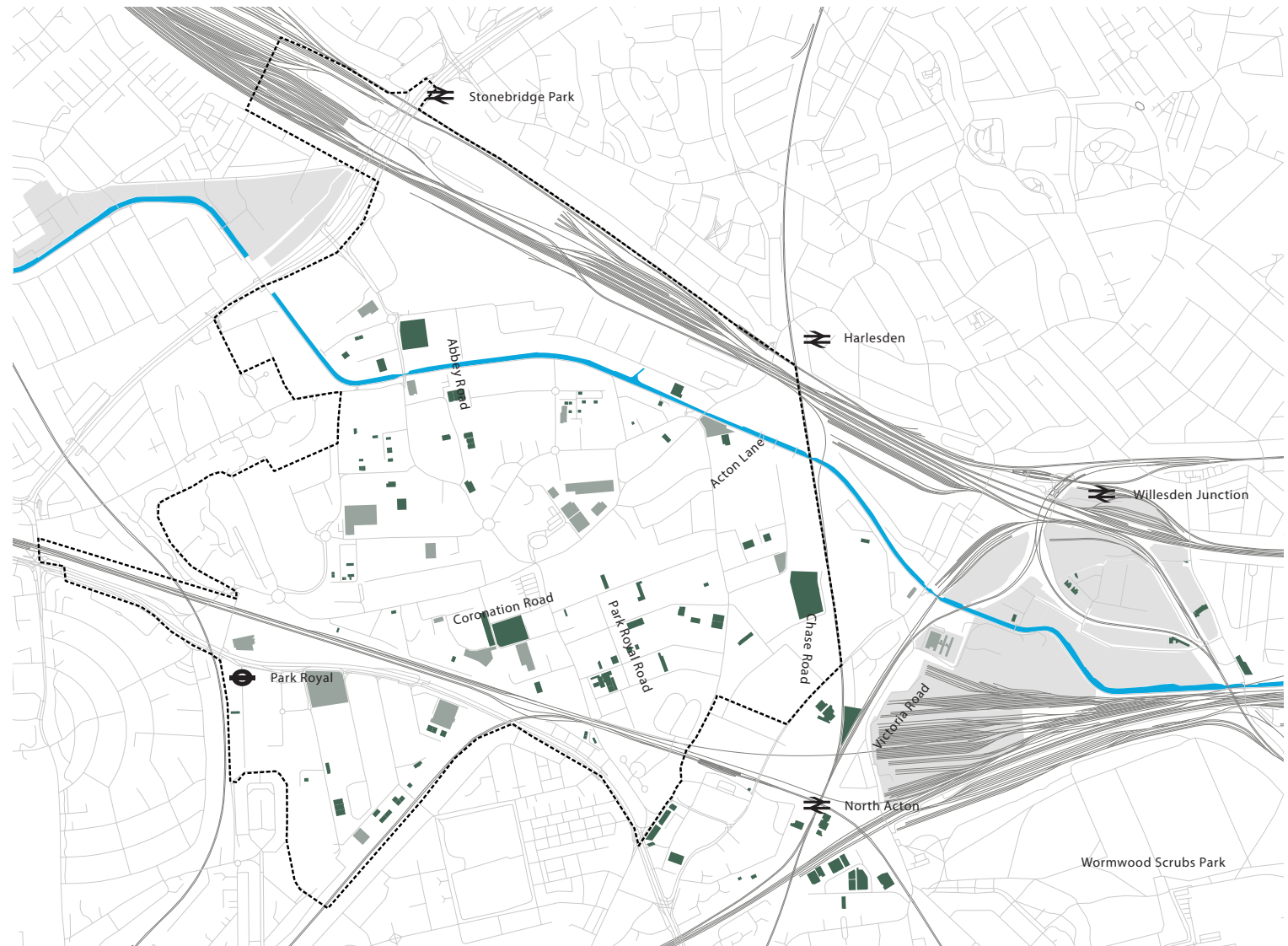

## 2 Context

### 2.2 Businesses

#### 2.2.3 Employment Density

##### Benchmark densities

Compared to other London industrial estates, parts of Park Royal achieve very high employment densities, particularly areas of dense light industrial fabric (Industrial Land Review page 29).

Although as a whole Park Royal has a lower employment density measured in floorspace area per employee, this is due to the large amount of land used for utilities and waste on Park Royal relative to other industrial areas in Outer London boroughs. These uses are key to the functioning of Park Royal and the city around it. They are also associated with more restricted flexibility in terms of policy requirements, location and/or compatibility with other uses and/or operating parameters. Therefore, this study will focus on other industrial uses. However, the challenge remains that intensification strategies would still be seeking to increase the density of an urban fabric which is already relatively dense.

Sources: Industrial Land Review, OPDC 2016  
 London Industrial Land Supply & Economy 2015 (AECOM, Cushman & Wakefield, We Made That)  
 North East Enfield Employment Study 2016 (We Made That)  
 Old Kent Road Employment Study 2014 (GLA & Southwark Council)  
 Charlton Riverside Employment Activity & Heritage Scoping Study 2017 (in progress, We Made That & James Hulme)

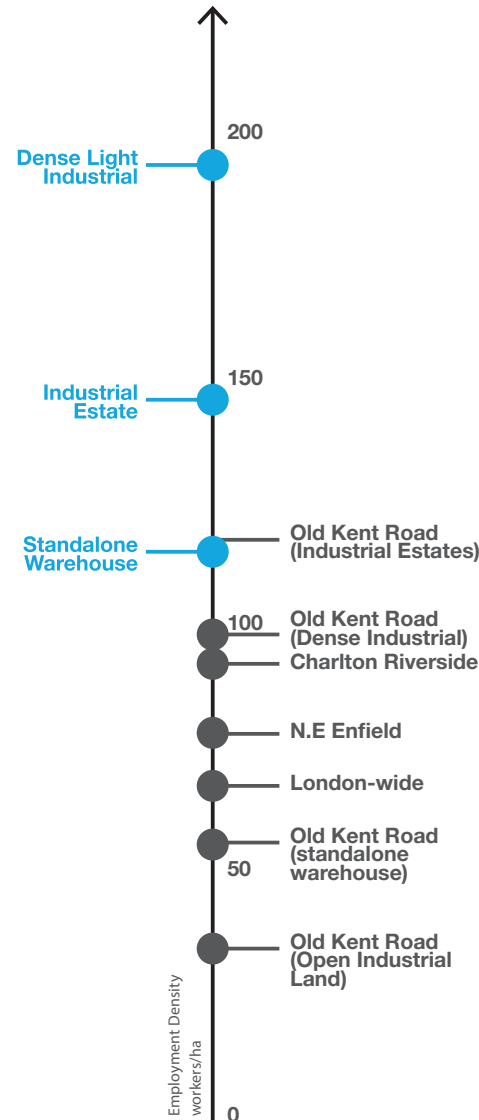

## 2 Context

### 2.2 Businesses

#### 2.2.4 Employment Density

##### Densities by Location





Employment densities are higher in Old Park Royal where the urban grain is tighter, and where transport supports more intensive use of workspace.

Areas of more modern, larger standalone warehouses have lower employment densities, reflecting the nature of the businesses that use these spaces and the inefficiencies of incorporating large industrial units on sites.

There is little correlation between location and site job density, which suggests that there could be opportunities to better exploit public transport accessibility..

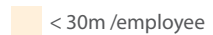
m<sup>2</sup> per employee  
Mapped using ILR  
database

Key

	< 30m /employee	High Density
	30 - 40m /employee	
	40 -50m /employee	
	50+ m /employee	Low Density
	.....	Study area boundary

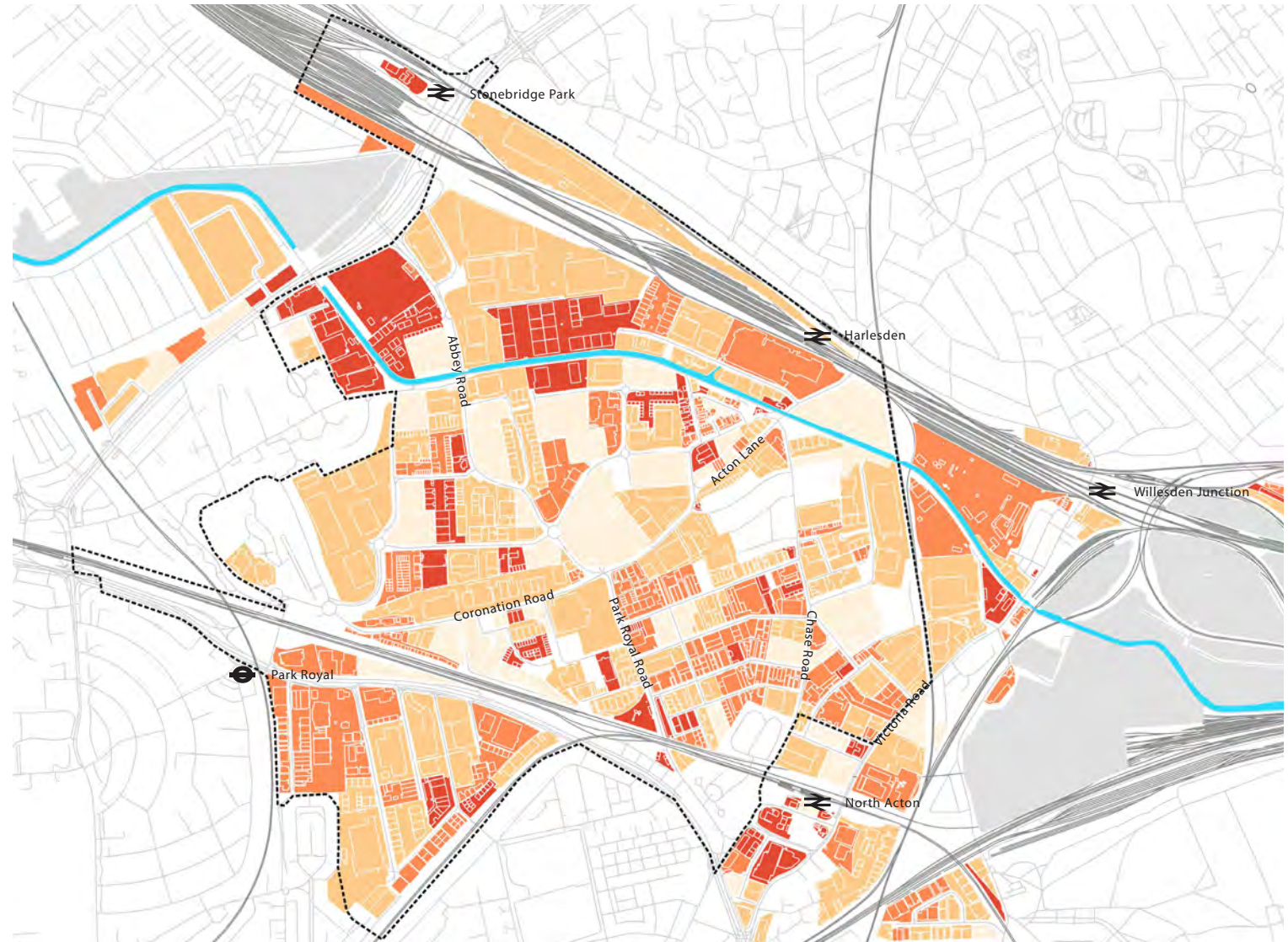

## 2 Context

### 2.3 Market

#### 2.2.5 Market Research

##### General Commentary on the Market

- Park Royal is a very popular location for industrial-based occupiers who serve London and need geographical proximity to function commercially.
- A lot of sites with the opportunity for redevelopment exist, however:
  - Opportunities coming to the market are very scarce.
  - Those opportunities that do come to the market (whether with or without buildings on them) are achieving values way beyond the conventional calculation based in investment value) – values achieved £1.8 - £3.6 million per acre – very high compared to other industrial locations in Greater London.
  - Particularly high demand for sites (with / without buildings) from owner occupiers.
- Industrial / B1c workshop without loading bays and yard space are not delivered by the market as they do not meet modern operational requirements which means they are less attractive to investors. Properties should aim to meet an investment standard which will make them trade-able and deliverable. New units delivered to optimal standards in prime locations are referred to as Grade A.
- Developers generally avoid delivering new smaller, multi small unit developments due to the higher management requirements which makes owning a property as an investment less attractive when compared with other employment investment opportunities. Larger units generally tend to have lower management requirements. Therefore developers will always opt for this size unless there is a particular incentive to deliver small units. That said there are more enterprise-minded developers out there who will deliver smaller multi-unit schemes, to meet a gap in the market.
- Proximity of tube and rail stations is a key consideration for office occupiers (and therefore developers). This has an impact on investment decisions and therefore the rent potential occupiers/tenants are willing to pay when comparing with alternative sites and locations. Developers may need to incentivise in other areas to attract tenants, e.g. rent free period or fit out specification.

## 2 Context

### 2.3 Market

#### 2.2.6 Key Value Drivers in Park Royal

Park Royal is characterised by high demand for industrial space (includes B1c, B2 and B8), but with limited supply of land for development as well as built space across all sizes and grades. This reflects Park Royal's status as a key strategic location that services the needs Central and Greater London. The high demand and short supply is reflected in higher average rents than many other industrial locations of London. Secondly, investors perceive Park Royal to be a strong location to invest in property due to its ability to attract good quality tenants. This is reflected in good yields of between 4.25% - 5.25% for new build industrial and 4.75% - 6% for lower quality industrial stock.

Anecdotally, another key characteristic of Park Royal is the high level of demand for sites and existing built industrial space from owner occupiers who are prepared to pay values higher than the wider market to secure for space or sites. This has the effect of making the market even more competitive and higher values being paid to secure the desired space.

Higher average industrial rents and more favourable yields alongside current construction cost levels mean industrial is a viable use to deliver. This assumes that the site can be acquired at market rates for industrial land.

Park Royal is not currently a recognised office location and rents achievable for new space are low relative to the cost of constructing new space. It is therefore unlikely that new stand alone office developments will be delivered at the current time. However, there are opportunities to deliver additional office space through a combination of conversion of other employment space (cost effective), refurbishment of existing

office (cost effective) and/or alongside a high proportion of new industrial space (a value driver).

Values achievable are intrinsically linked to the demand-supply balance of a given use in Park Royal, particularly office where demand is lower compared to industrial.

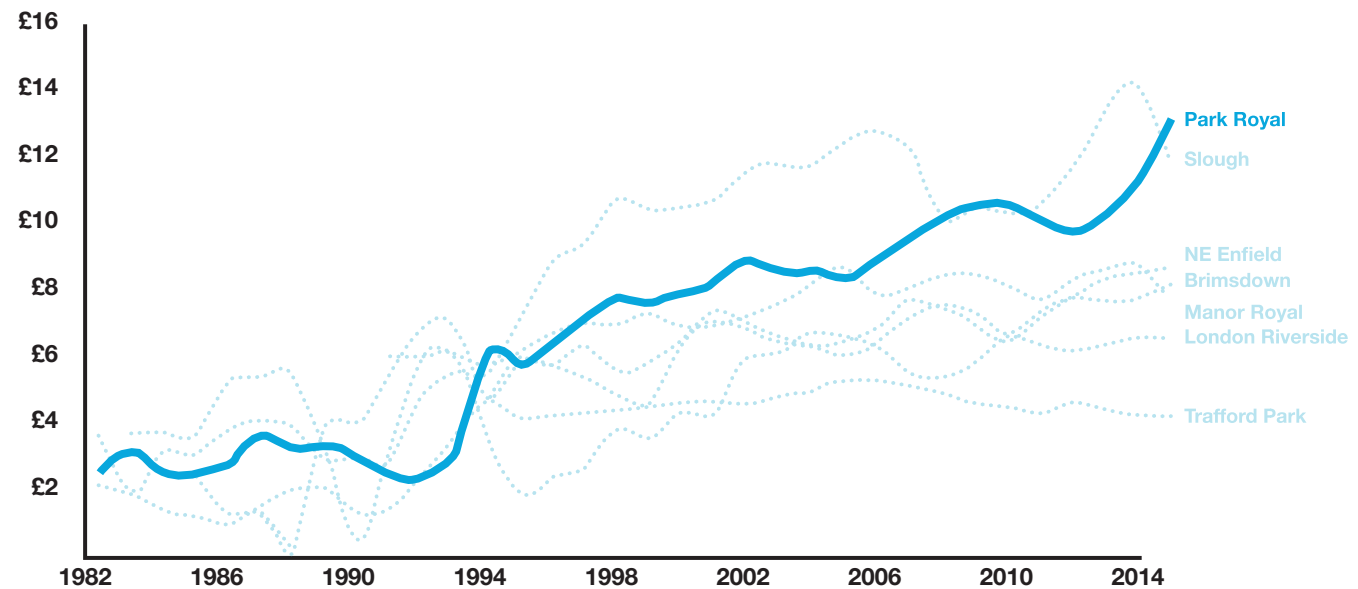

Year Rolling Average Rental Rates for Industrial Units (£/sq-ft)

## 2 Context

### 2.4 Spatial Policy

#### 2.3.1 Policy Context

The Local Plan sets out the long term vision and policy framework based on three key priorities: to protect, strengthen and intensify the Park Royal industrial area. The Local Plan includes specific measures to ensure Park Royal will continue to function as a crucial industrial area, and also determines the extensive change that will happen around the estate's periphery.

Extensive change is planned as part of the development of Old Oak Common and the works associated with HS2 construction. The re-composition of the uses and enhanced connectivity offers potential that could encourage intensification, particularly associated with better transport connectivity, new businesses and a well skilled population.

It is critical, therefore to increase employment density in areas that can take advantage of these changes.

Park Royal currently has a poor number of employees within a commutable travel time of 1 hour, largely due to traffic congestion within London, which is identified as a weakness in the Industrial Estate Research Study (2016).

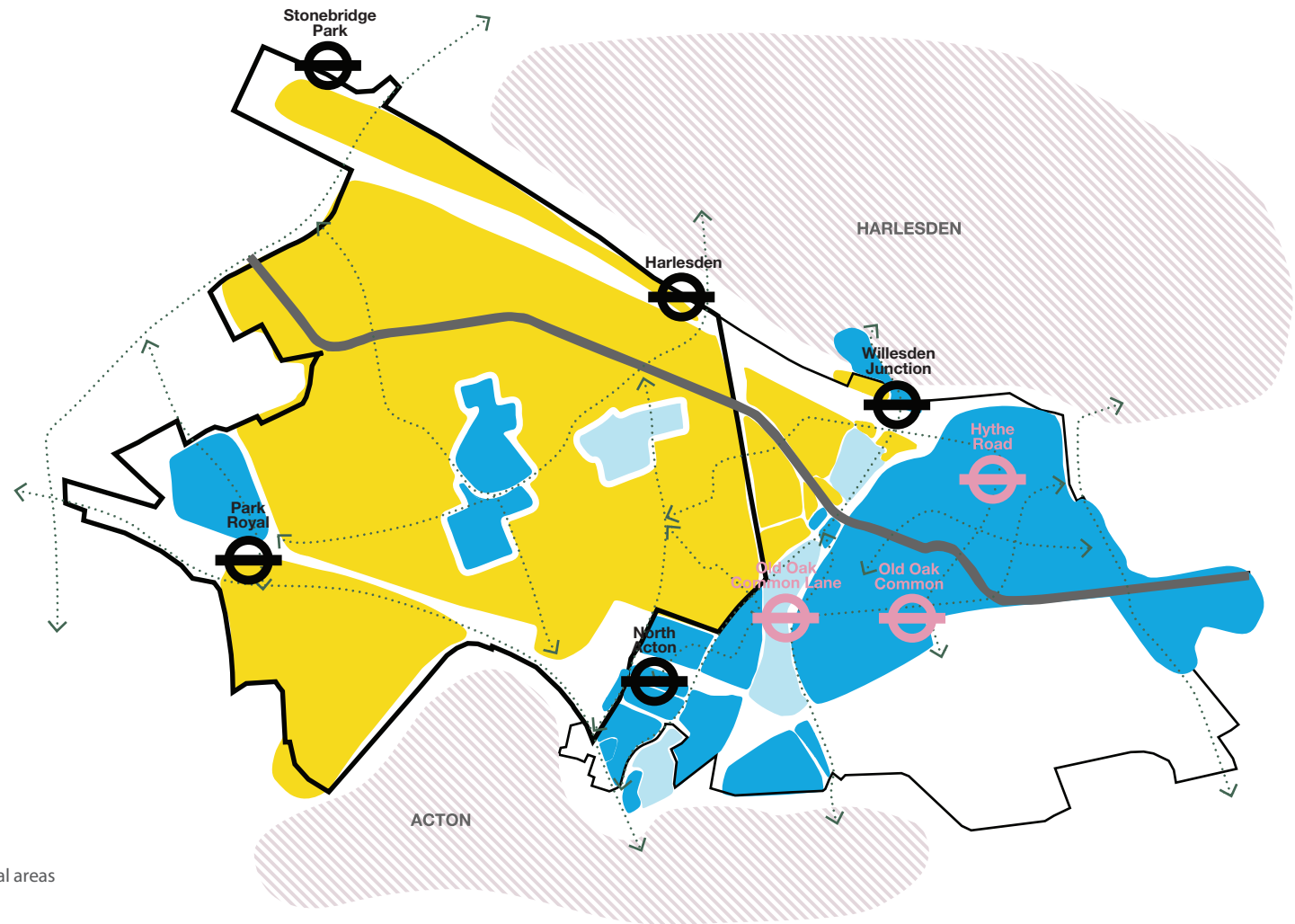

- Mix of uses
- Existing residential areas
- Key Routes
- Industrial uses

## 2 Context

### 2.5 Future Business Growth

#### 2.3.2 Future Growth Sectors Study

OPDC's Future Employment Growth Sector Study identifies a number of sectors around which future employment growth across the OPDC area is likely to be focused. While these sectors vary significantly in terms of their size, they are all activities which either currently define the OPDC economy, and / or which could contribute to future aspirations for economic growth, diversification and placemaking in the area.

Existing economic strengths are largely in industrial type activities, in particular food manufacturing, transport, wholesale, logistics and to a lesser extent, motor trade activities. The area also appears to have growing strengths in a range of creative industries. There are opportunities to retain, strengthen and diversify these sectors.

In addition, a number of new sector opportunities have been identified. The nature of development at Old Oak Common means that future growth is likely to be focused around office uses such as professional and financial service, ICT and digital media sectors. There are also potential opportunities within the low carbon (including clean tech), higher value manufacturing sectors and med-tech activities.

**Conclusions – Sector Locations**  
The Future Employment Growth Sector Study draws conclusions on how the growth sectors could evolve spatially across Old Oak and Park Royal in future years, and how they might be supported to do this.

These spatial conclusions are intended for illustrative purposes to broadly highlight the types of location which each sector is likely to be most suited to, taking into account current economic and spatial characteristics, future development

potential and phasing, local amenities and infrastructure and the specific needs of each sector:

1. Old Park Royal: craft/artisan manufacturing and shared maker spaces; smaller wholesale activities, smaller creative businesses, shared workspaces and flexible B1c units.
2. Western Periphery: larger logistics and distribution activities, and car retail dealerships near strategic routes
3. Channel Gate: as part of larger area linked to HS2 construction sites
4. Victoria Road: Smaller food manufacturing and wholesale businesses, smaller creative businesses, shared workspaces and flexible B1c units
5. Park Royal/Core SIL Areas: Mix of small and large businesses across all industrial sectors, alongside some business support service activities in B1a and flexible B1c units where appropriate.

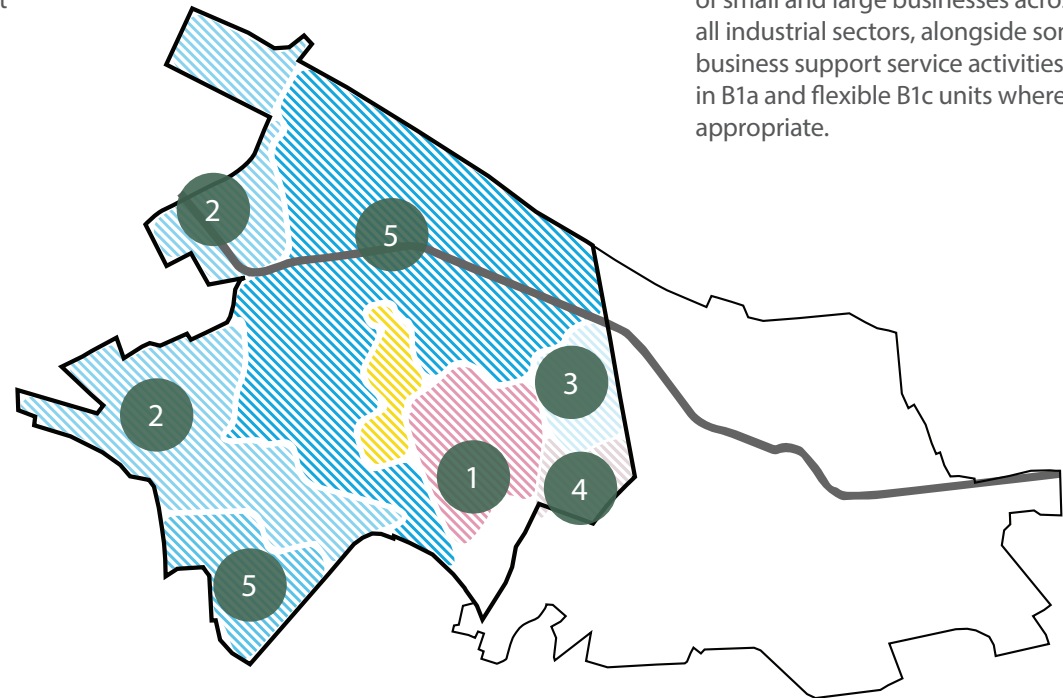

## 2 Context

### 2.5 Future Business Growth

#### 2.4.1 Employment Target

# 36,000

Total estimated jobs within OPDC.





The study will provide a strategy consistent with the London Plan target of the provision of an additional 10,000 new jobs at Park Royal.

The study area excludes parts of Park Royal that will be utilised for HS2 construction compounds until 2026. As a significant amount of jobs are anticipated to be delivered on these HS2 sites, this study aims to deliver 4,000-4,500 within the study area.

The priority for SIL is to safeguard land for industrial uses, further job growth should not compromise this overriding imperative.

As there are few open development sites within Park Royal, and the OPDC is not a major landowner in this area, this study will pursue design approaches that encourage incremental growth to deliver this uplift in employment densities

#### Areas

-  Park Royal study area
-  SIL outside study area
-  Non industrial land
-  OPDC Boundary

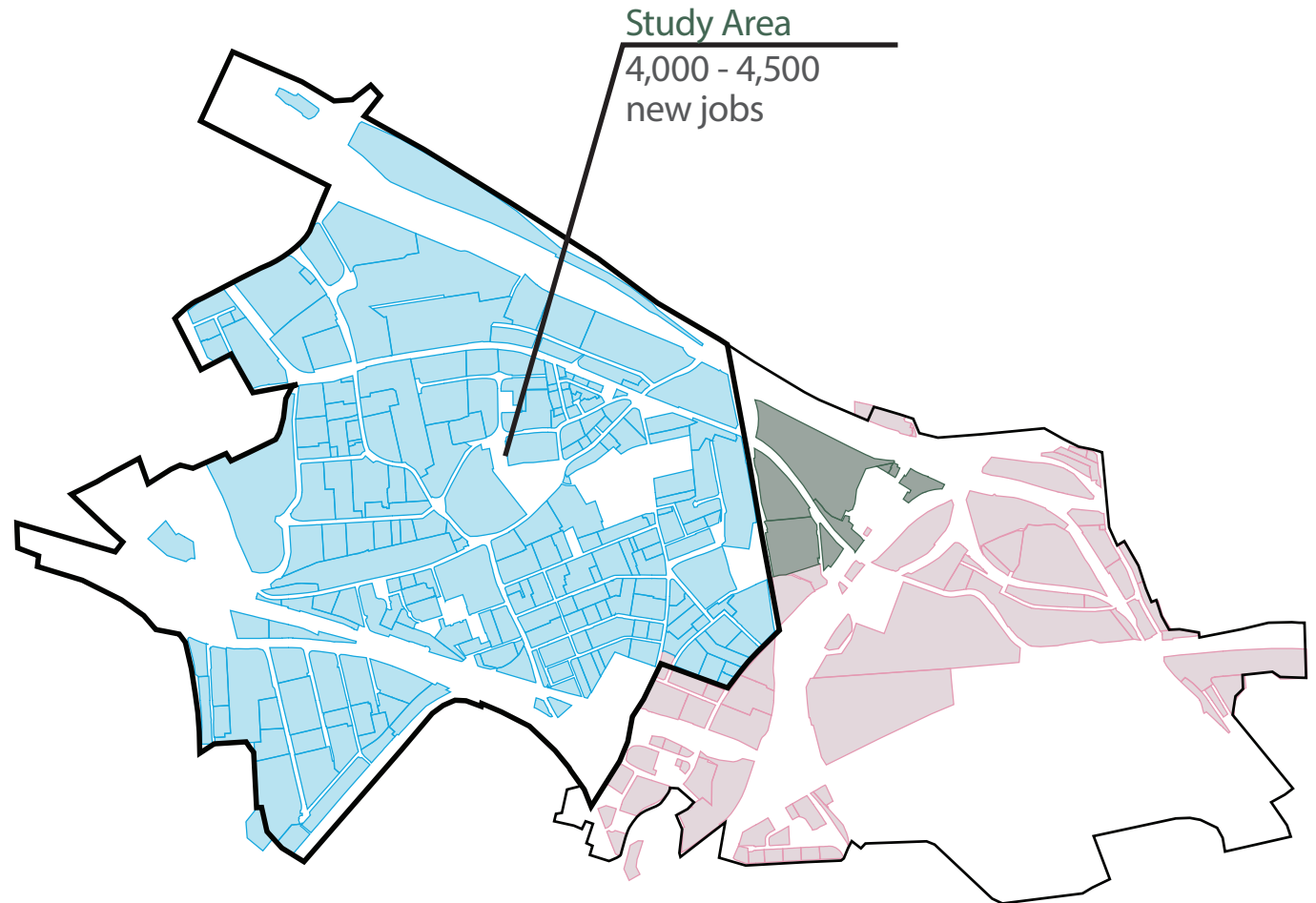

## 2 Context

### 2.5 Future Business Growth

#### 2.4.2 Future Growth Sectors



#### Conclusions – Scenarios for Sector Growth

The Future Growth Sectors report provides a series of conclusions on scenarios for future sector growth. Aside from sector specific drivers, these will be driven by:

- Locally specific considerations include the physical capacity for growth in the OPDC area, the transformational effect of the proposed transport enhancements, and the proactive planning and economic development policies of OPDC and its partners.

- Wider considerations include the overall trajectory of the UK and global economy and wider macro-economic considerations, economic competition, and changes in technology and working practices

The report concludes that growth in Park Royal is likely to be based around existing strengths (e.g. food and transport and logistics), albeit with potential for diversification and innovation as sectors evolve and adapt.

Reflecting constraints in existing capacity in Park Royal, the scale of growth will largely be driven by the delivery of intensification. Potential for economic intensification is greatest within the food and other manufacturing sectors as these deliver stronger employment densities than logistics and distribution. Alongside core industrial activities, business support service activities also provide some potential for strong levels of economic intensification where appropriate.

## 2 Context

### 2.5 Future Business Growth

#### 2.4.2 Future Growth Sectors

#### Future Growth Sectors

	Use Class	Spatial Requirements				
		Small Office < 500 m <sup>2</sup> / 5,400 ft <sup>2</sup>	Studio / Workshop / Lab < 500 m <sup>2</sup> / 5,400 ft <sup>2</sup>	Small Warehouse < 500 m <sup>2</sup> / 5,400 ft <sup>2</sup>	Small Box 500-929 m <sup>2</sup> / 5,400-10,000 ft <sup>2</sup>	Medium / Mid / Large Box > 929 m <sup>2</sup> / >10,000 ft <sup>2</sup>
Food Manufacturing	B1c, B2			●	●	●
Transport & Logistics	B1c, B8				●	●
Motor Trades	Sui Generis			●	●	
ICT, Media & Creative	B1a, (B1c)	●	●	●		
Business & Professional Services	B1a	●	●	●		
Creative Manufacturing	B1c, B2		●	●	●	
Advanced Manufacturing	B1c, B2, (B1b)	●	●	●	●	
Low Carbon	B1a, B1b, B2	●	●	●	●	●
Life Sciences	B1b	●	●	●		

#### Conclusions – Spatial Requirements

The spatial requirements of sectors highlighted in the Future Employment Growth Sectors Study show that a range of spaces are required. The intensification strategies developed must therefore be broad and ensure that a diversity of space is provided.

Spatial requirements vary both between and within sectors. For examples, while there is established demand for very large distribution premises in the logistics

sectors, that sector also accommodates considerable and growing demand for smaller wholesale premises. While spatial requirements also vary considerably within the food manufacturing sector; demand is increasingly focused around small and flexible B1c units which allow room for expansion / contraction. Common across many of these industrial sectors is a requirement for strong and reliable access and space for adequate space for parking and loading.

The study also highlights the growing demand for a range of flexible workspace typologies for SMEs – from managed workspace, to incubators, accelerators and co-working spaces, to studio spaces and maker spaces. The study notes that demand is likely to continue to evolve in future years and as a result ongoing monitoring of requirements will be required. As such intensification strategies should take into consideration this medium and longer term potential for sector growth, alongside current immediate market needs.

## Section B Intensification Strategy and Principles

## 3 Intensification

We have developed a data-driven method to identify sites where industrial intensification will be most effective and most deliverable.

3.1 Intensification Strategy

3.2 Intensification Types

3.3 Site Identification

# 3 Intensification

## 3.1 Intensification Strategy

### 3.1.1 Key Drivers

#### Protect SIL

##### Demand for SIL Land From Industrial Sectors

As industrial land has been lost at a rapid rate across London, remaining industrial land is increasingly in demand. Park Royal is of strategic importance as London's largest reservoir of industrial land. Intensification of sites can help increase floorspace capacity and therefore help to accommodate ongoing demand for industrial space

Attracting the investment that will deliver intensification relies on protecting this SIL designation. Investors need to have the confidence that the area will continue to function successfully as industrial land in the long term in order to justify the investment required today.

The mix of uses and location of uses within sites should reflect this through incorporating industrial and related uses whilst ensuring ancillary uses do not have an adverse impact on the functioning of core industrial uses.



New industrial space, Park Royal

# 3 Intensification

## 3.1 Intensification Strategy

### 3.1.1 Key Drivers

#### Employment Density

##### Multi-Storey Typologies

Although currently uncommon in industrial areas in the UK, multi-storey typologies can deliver significant uplift in employment density.

Where site conditions allows, stacking of small industrial spaces on larger industrial spaces can maintain the ecology of businesses in Park Royal whilst growing the employment capacity of the area.

Where site conditions do not allow for viable multi-storey B2/B8 industrial typologies, introducing B1 uses on upper levels can maximise the capacity of sites, and create significant uplift in additional employment capacity.

##### Location

Employment density can be uplifted through exploiting the potential of specific parts of Park Royal.

There is a clear opportunity is to exploit sites with good PTAL, where occupiers with large workforces are likely to be willing to locate.

Existing high density clusters, such as business centres can be extended, providing more space in locations that are already desirable locations and offer

incentives for businesses to work in closer proximity.

Although B1 uses create high densities of employment, it is also crucial to ensure B2 space is retained in smaller sites in Park Royal, as these sites are likely to attract manufacturing activities.

##### Innovation

New approaches to industrial development and industry itself can drive intensification.

New technologies are creating new manufacturing sectors that are cleaner and quieter, and can hence be accommodated in closer proximity with other types of workspace than before.

Technologies such as modular and pre-fabricated construction are bringing down the costs of industrial buildings to assist in making multi-storey industrial development viable.



High density workspace, Munich

# 3 Intensification

## 3.1 Intensification Strategy

### 3.1.1 Key Drivers

#### Delivery of Viable Space

Industrial space is the most viable space to deliver in Park Royal due to the strong rental values achievable relative to the cost of constructing new space. Industrial space is conventionally delivered as single storey buildings particularly on small to medium size plots. In the UK, industrial developments of 2 storeys and above are still rare as it requires a very large site to achieve building cost economies of scale and very strong industrial rental values to cover the higher cost of building.

Although it is unlikely that new stand alone office developments will be delivered due to rental values being relatively low compared with construction costs for this type of space, B1 space could possibly be delivered alongside a higher proportion of value generating industrial space.

A key consideration for delivering viable forms of intensified development is – in addition to the cost of more substantial structures – the requirement for additional passenger lifts, loading lifts and vehicle ramps required to service buildings to the same level as comparable single storey buildings. This is critical to ensure they are attractive to tenants and attract the best possible rents and lease terms. This also has a bearing on how attractive a development is as an investment.

Values generating industrial space can accommodate the cost of providing additional servicing but needs to be of sufficient scale and a high proportion of a development on a given site. The delivery of new industrial and office space must not compromise the proportion of land given over to yard space and car parking otherwise tenants will not take new space. This would negatively impact on viability through lower rental values.



Large-scale multi-storey development, Heathrow

# 3 Intensification

## 3.1 Intensification Strategy

### 3.1.1 Key Drivers

#### Place

##### Architectural Approaches

Creating more jobs in Park Royal relies on making places where businesses would like to locate. Attracting business can be helped through an improved urban realm.

Architecturally, a great deal can be done to improve the experience of moving through Park Royal. Better frontages can be created through ensuring building entrances are located directly on streets and allowing buildings to form the boundary of sites.

Park Royal's heritage buildings can also be refurbished to build upon the industrial heritage of the area, building a distinctive character.

##### Urban Approaches

At a strategic level, creating different types of streets further enhances the architectural approaches described above. Distinguishing streets that are used to service buildings from those where pedestrian movement, visitor journeys, amenity space and food/beverage uses are located can create a much better urban environment which attracts businesses to the area and improves employee welfare.

Consolidating service yards, freeing up frontages elsewhere for public facing activities can deliver this.

Exploiting amenity spaces such as the canal, parks and vegetation is an opportunity to improve the urban experience of Park Royal.



Positive industrial frontage, Park Royal



Pedestrian friendly public realm, Barcelona



Comprehensible building entrances, Farmington, US



Material articulation of building, Melksham

# 3 Intensification

## 3.1 Intensification Strategy

### 3.1.2 Types of Intensification

#### Intensification

For the purposes of this study, intensification is considered to be an increase in employment densities across Park Royal, but where this includes industrial uses in line with the area's SIL designation and takes opportunities to increase floorspace capacity.

However, intensification can be considered in other forms, such as an increase in the mix of uses, a more active public realm, increases in productivity, and increases in efficiencies of land-use and industrial processes.

Whilst the driving metric for this study will be employment densities, this can also be aligned with increasing floorspace and with broader intensification through co-location, shared facilities, agglomeration effects and so on.

Increasing employment densities requires a broad strategic approach, particularly in accommodating the higher concentration of pedestrians, car journeys and service vehicles. These issues are being considered in other studies.

There are a number of opportunities and constraints which are relevant to intensification presented overleaf.

**Process** Increasing efficiency through improvements to technologies used, or through sharing facilities to maximise use



Shared workshop, Hackney

**Economic** Changing type of accommodation to attract higher value added uses



High value manufacturing, Brooklyn Navy Yards, New York

**Spatial** Increase intensity of land-use



Multi-storey industry, Theydon Road, Hackney

**Urban** Improve contribution to quality of urban realm



Positive frontage, Herman Miller, Melksham

# 3 Intensification

## 3.1 Intensification Strategy

### 3.1.3 Opportunities

Ageing building stock Some areas have many buildings coming to the end of their lifespan, creating opportunities for redevelopment.



Variation A wide variation in building and site typologies across Park Royal presents a range of possibilities for intensification.

Sharing facilities Efficiencies created through sharing facilities are becoming more common, incentivising intensive use of space and bringing new arrangements for managing sites.



Low rise urban fabric Existing stock mainly 1-2 storey buildings, ensuring multi-storey typologies present opportunity for an increase in densities.



Innovation New business models and development models are being developed in London, and can provide the impetus to intensify Park Royal.

# 3 Intensification

## 3.1 Intensification Strategy

### 3.1.4 Constraints

**Low vacancy** With little vacant land available in Park Royal new intensive typologies must replace existing buildings, and account for costs and values generated.



**High private ownership** Intensification will depend on individual landowners developing sites.



**Existing infrastructure** The quality and capacity of existing infrastructure could affect future investment, if not addressed



**Existing building stock** Existing building stock is mainly of secondary and tertiary quality, meaning that incremental development which seeks to retain existing buildings may be commercially challenging.



**Residual land fragmented** Spaces around existing buildings irregular in shape, creating challenges in providing standardised spaces through incremental intensification such as horizontal extension and infill.



# 3 Intensification

## 3.2 Intensification Types

### 3.2.1 Spatial Intensification

The following pages sets out the intensification types and how case study sites have been selected.



A number of opportunities exist for intensification in Park Royal, from the incremental to the comprehensive. These are set out in the table opposite.

Specific spatial conditions make each intensification type feasible on certain sites, and likewise the incentives and risks for redevelopment vary accordingly.

As such, there is no singular way to determine whether a site is appropriate for redevelopment- the way sites are identified must suit the type of intensification envisaged.

Therefore, a number of indicators are used to select sites based on the spatial conditions and incentives associated with each intensification type. These indicators are set out on the following page.

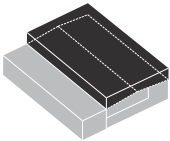
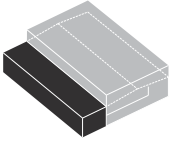
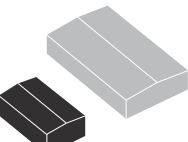
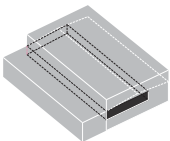
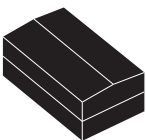
Once a number of sites are located which match the conditions for intensification, this is narrowed down to a number of case studies through assessing the likely commercial viability of redeveloping these sites. The workflow is explained on page 43.

Intensification Type	Suitable Site Type	Incentive for Development	Risks
Vertical Extension 	Spatially constrained sites	Increase in floor area	Impacts on current occupiers staying operational. Dependant on structural capacity of existing building.
Horizontal Extension 	Sites with underutilised space	Increase in floor area, with the capacity to extend existing site operation	May be fewer opportunities across Park Royal due to high density
Infill 	Sites with large amounts of un-utilised/underutilised space	Increase in floor area with minimal impact on existing occupants	May be fewer opportunities across Park Royal due to high density
Internal Subdivision 	Buildings with sufficient eave heights to accommodate mezzanine floors	Increase in floor area with or without significant structural modifications to existing building	Significantly changes the nature of accommodation possible within building, but could be useful for buildings which have been experiencing long void periods.
New Provision on Vacant Land 	Vacant sites	Provision of high density, high quality accommodation suiting market demand	May be fewer opportunities across Park Royal due to low vacancy rates, but may become more important as buildings reach end of their life.
Comprehensive Redevelopment 	Large sites under single ownership	Significant upgrade in quality of accommodation and floor area	Requires strong actor to carry risk of large redevelopment, but may become more important as buildings reach end of their life.

### 3 Intensification

#### 3.3 Site Identification

##### 3.3.1 By Intensification Type

Spatial Characteristic	Indicator	Intensification Type				
		Horizontal Extension/Infill	Vertical Extension	Internal sub-Division	New provision / Comprehensive Re-development	New Development on Vacant Land
Large proportion of site not used for operational uses	Area Efficiency Source: ILR Data Business, Park Royal Atlas					
Low buildings not exploiting potential for multiple storeys	Floor to Area Ratio Source: ILR Data Business, Park Royal Atlas					
Height of building/eaves offer potential for mezzanine level	Volume Efficiency Source: ILR Data Business, Park Royal Atlas Building Height, EMU Analytics					
Multiple buildings under single ownership potential for phased, redevelopment of large sites	Buildings per Freehold Source: Freeholds, Park Royal Atlas					
Vacant site available for new development	Vacant Sites Source: Park Royal Atlas					
Location could support significant increase in employment densities	PTAL TfL					
Location appropriate for Future Growth Sectors	Future Growth Sectors Future Growth Sectors Report, OPDC					

# 3 Intensification

## 3.3 Site Identification

### 3.3.2 Site Identification Work Flow

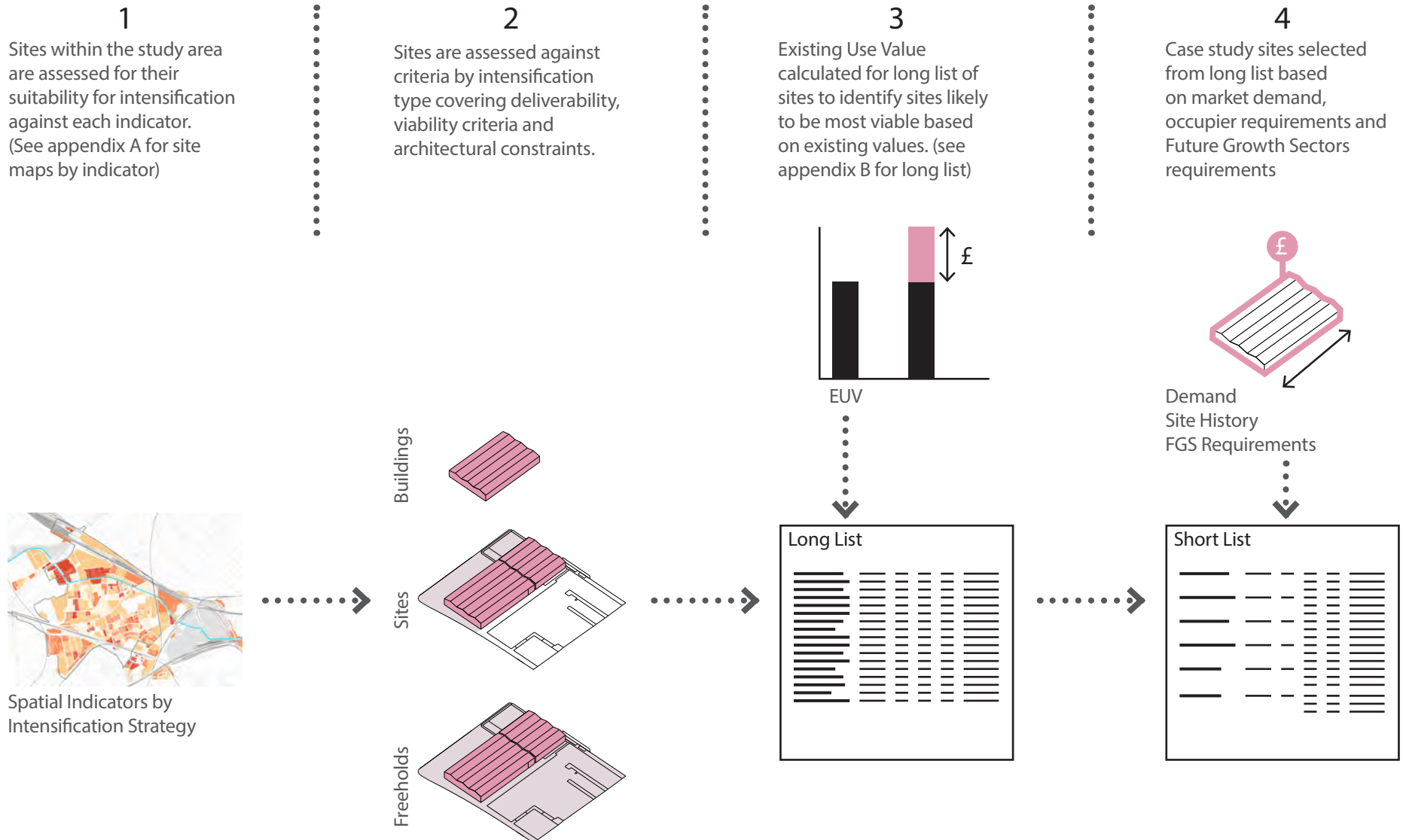

# 3 Intensification

## 3.3 Long List

### 3.3.3 Selected Sites by Site Type

- Standalone warehouse
  - 1. Ryder, Abbey Road
  - 2. HSS Hire, Abbey Road
  - 3. Willen Field Road
  - 4. Gorst Road
  - 5. Waxlow Road
  - 6. North Acton Road
  - 7. Nucleus Business Park
  - 8. John Lewis Depot
  
- Industrial estate
  - 9. Grand Union Trading Estate
  - 10. Space Business Park
  - 11. Bush Industrial Estate
  - 12. 97 Victoria Road
  - 13. Kendal Court
  - 14. Westwood Park
  
- Dense industrial
  - 15. Park Royal Fire Station
  - 16. 40 Minerva Road
  - 17. Alliance Court
  
- Open industrial land
  - 18. Twyford Tip
  - 19. 56A Minerva Road
  - 20. Western road
  
- Business centre
  - 21. (7-11) Minerva Road
  - 22. Premier Park
  
- High street type
  - 23. Abbey Manor
  
- Vacant lot
  - 24. Bashley Road
  
- ..... Study area boundary

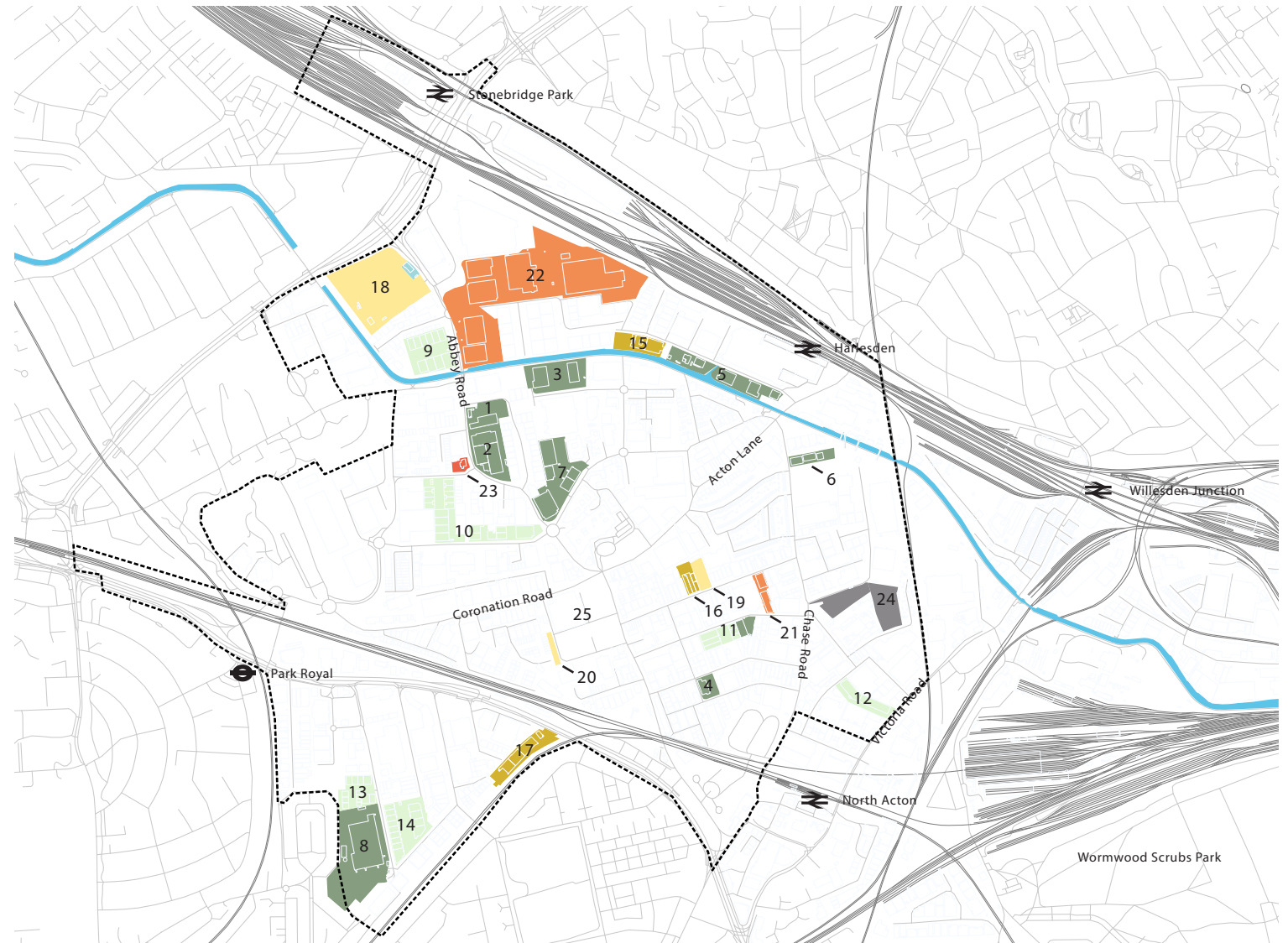

# 3 Intensification

## 3.3 Long List

### 3.3.4 Selected Sites by Intensification Method

- Horizontal Extension
  - 23. Abbey Manor
  - 6. North Acton Road
  - 7. Nucleus Business Park
  
- Vertical Extension
  - 2. HSS Hire
  - 12. St Leonard's
  - 16. 40 Minerva Rd
  - 17. Alliance Court
  - 21. (7-11) Minerva Road
  
- Vertical / Horizontal Extension
  - 3. Willen Field Road
  - 5. Waxlow Road
  - 15. Park Royal Fire Station
  
- Infill
  - 1. Ryder
  - 8. John Lewis Depot
  
- Internal Subdivision
  - 22. Premier Park
  
- New Provision on Vacant Sites
  - 18. Twyford Tip
  - 19. 40-54A Minerva Road
  - 20. Western Road
  - 24. Bashley Road
  
- Comprehensive Development
  - 4. Gorst Road
  - 9. Grand Union Industrial Estate
  - 10. Space Business Park
  - 11. Bush Industrial Estate
  - 13. Kendal Court
  - 14. Westwood Park
  
- ..... Study area boundary

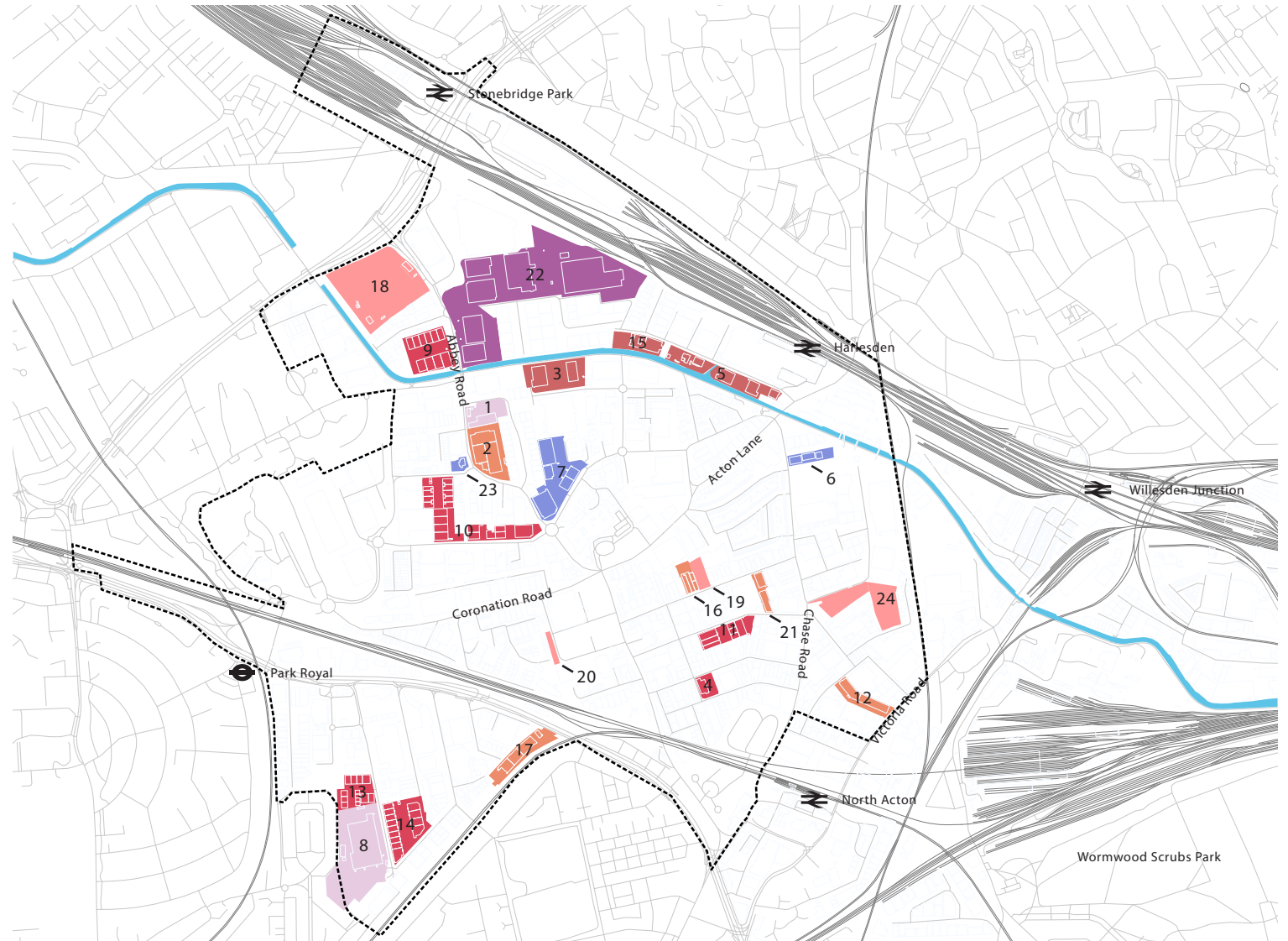



## 4 Typologies

The following case studies test the future employment capacity potential on each selected site.

4.1 Design Principles

4.2 Case Studies

4.3 Stakeholder Consultation Summary

4.4 Viability Methodology

4.3 Viability Summary

## 4 Typologies

### 4.1 Design Principles

The intensification of industrial fabric requires new approaches to design, both at the individual site level and at the urban scale.

The following principles can be applied on sites of varying scales across Park Royal to ensure that intensification is feasible and viable.

These principles inform the design development of exemplar case studies that reflect the employment density, viability and placemaking set out in section 3.

They are principles that can be applied to the wide variety of typologies that will be required to achieve significant uplift in employment numbers and floorspace across the study area.

The principles form the basis for indicative designs that demonstrate how new approaches could be adopted. These principles can guide the development of designs through the planning process and do not reflect consented schemes.

Section 4.2 sets out the designs for viable intensification strategies on the case study sites. These are notional concept designs only and are not planning proposals. Any delivery of B1a uses must be demonstrated

to be ancillary and are dependent on a high proportion of broad industrial type activities being delivered.

#### Intensify

Creating a more intensive use of land in Park Royal can be achieved through stacking industrial building types into multi-storey developments.

Sharing facilities wherever possible also provides incentives for businesses to work in closer proximity, and liberating space for further development.

#### Create Value

Increasing the overall built area on a site and providing a variety of space types to align with market demand will support value generation.

Separating access for different space types, exploiting high transport accessibility and creating better places can all ensure that the value is created to incentivise intensification.

#### Encourage

Overcoming the inertia to redevelopment of sites can be encouraged through phased redevelopment.



Kaap Nord, Amsterdam  
Intensive industrial development incorporating a mix of uses

# 4 Typologies

## 4.1 Design Principles

### 4.1.1 Stack Uses

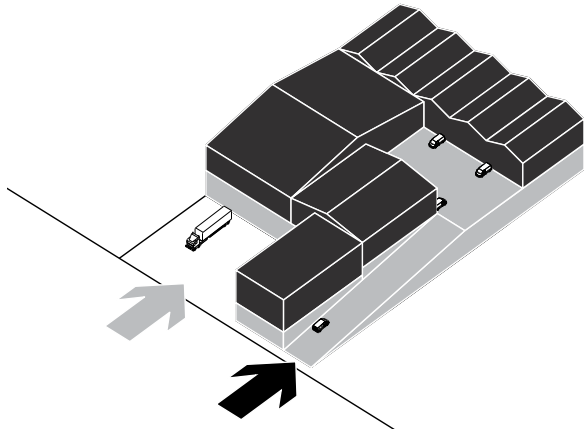

#### Design Principle 1: Stack Uses

Increasing floor space across Park Royal whilst maintaining a mix of space that provides for current and future businesses and does not compromise the area's SIL designation. This requires providing industrial spaces on upper storeys.

#### Typical Applications

- Vehicle ramp providing access to upper floors
- Separation of space requiring access for smaller goods vehicles from space requiring HGV access
- Use of goods lifts to provide servicing for light industrial spaces on upper floors
- Provision of B1 uses above B2/B8 industrial uses



Existing condition  
Predominant industrial typologies provide industrial space at ground floor. Where present, upper storeys are generally office space.



Multi-storey industry (Belasco Building, Irun)  
Ramps provide access for service vehicles, enabling industrial space to be accommodated on first floor.



Small over large (Belartza, Donostia-San Sebastian)  
Stacking different sizes of space maintains a varied employment offer.

# 4 Typologies

## 4.1 Design Principles

### 4.1.2 Share Facilities

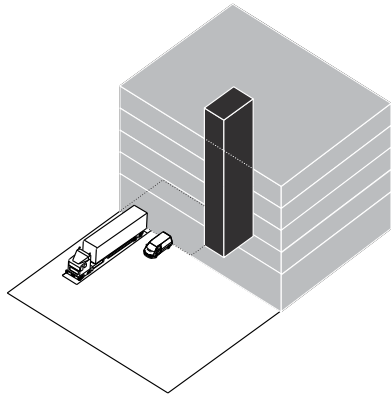

#### Design Principle 2: Share Facilities

Sharing of facilities can create more efficient, intensive use of space. Facilities for loading, storage, meeting space can be pooled and booked as required, allowing these facilities to be of a much higher quality and be more intensively used throughout the day.

#### Typical Applications

- Shared loading bays and yards, the scale of which is crucial to generating value from industrial spaces
- Goods lifts serving multi-storey light industrial space
- Consolidated office space sharing reception and circulation space
- Flexible space allowing a variety of businesses to share facilities



**Existing condition**  
Small industrial units have individual, separate loading access within minimal external space for loading.



**Shared Fab Lab (Chips Building, Manchester)**  
Use of common facilities can encourage business to work in closer proximity and utilise land more intensively.



**Shared facilities (RDM, Rotterdam)**  
Shared loading yard, fabrication facilities, assembly space and office space are available to tenants on a timed basis.

# 4 Typologies

## 4.1 Design Principles

### 4.1.3 Separate Access

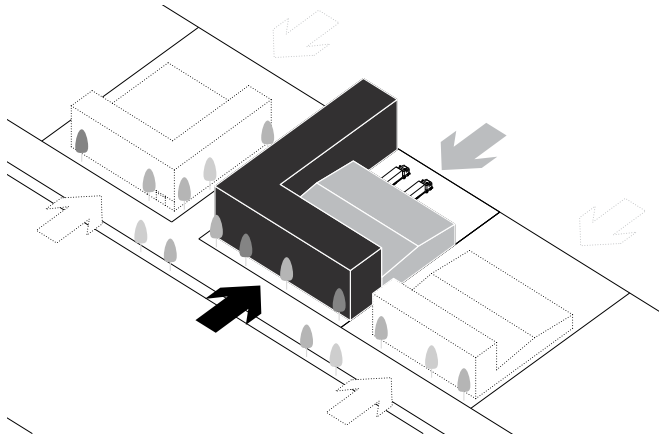

Design Principle 3:  
Separate Access/Service

Increasing the mix of space types on sites needs to be reconciled through separating different types of access, typically servicing and visitors/employees.

Typical Applications

- Dedicated entrance to office space directly off street
- Distinction of roads predominantly servicing industrial units from key pedestrian routes
- Clustering of office entrances



Existing condition  
Entrances for servicing, office access, visitors and food and beverage uses are intermixed along a street.



Create distinct street types (Poligon Industrial del Beson, Barcelona)  
Distinguishing between servicing and pedestrian friendly streets creates a more articulated public realm.



Positive frontage (Beiza Building, Donostia - San Sebastian)  
More pedestrian friendly streets are more attractive to occupiers, encouraging demand for intensified sites.

# 4 Typologies

## 4.1 Design Principles

### 4.1.4 Exploit Accessibility

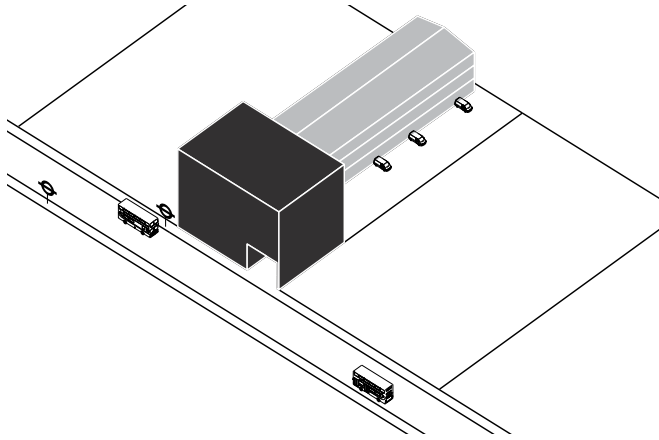

#### Design Principle 4: Exploit Accessibility

Increasing density in areas with good transport accessibility is vital to attracting occupiers. As well as ensuring that the space is marketable, this will also mitigate the impacts of increased traffic due to higher density of employment in Park Royal.

#### Typical Applications

- Location of high employment densities along bus routes and near tube/overground stations
- Location of B1 uses around perimeter of sites
- Maximise visibility of entrances



Existing condition  
Areas with good access to public transport, such as Old Park Royal.



Intensive Workspace (Netil House, Hackney)  
Good transport accessibility presents the opportunity for large buildings offering intensive mix of workspace



Campus (Here-East, London)  
High density employment enabled through good pedestrian routes between workspace and public transport.

# 4 Typologies

## 4.1 Design Principles

### 4.1.5 Phase Redevelopment

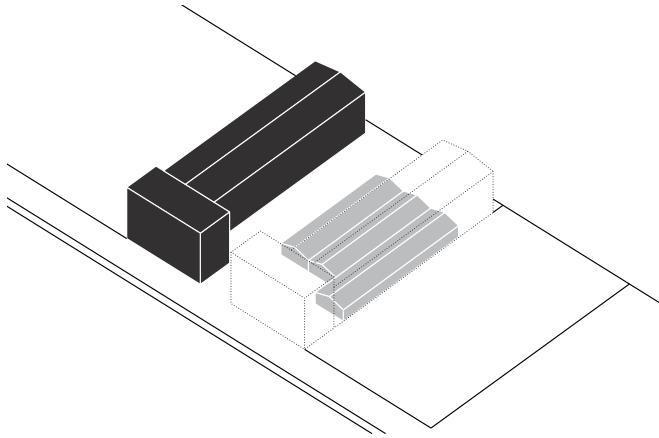

Design Principle 5:  
Phase Redevelopment

Redevelopment can be phased to ensure owner occupiers can stay operational and investors retain income through construction.

Typical Applications

- Strategic infill of low density sites allowing decant of businesses
- Redevelopment of sites with multiple buildings within a single Freehold
- Comprehensive redevelopment with adjacent sites through land assembly



Existing condition  
Dense industrial fabric has little space for redevelopment whilst the existing buildings remain operational.

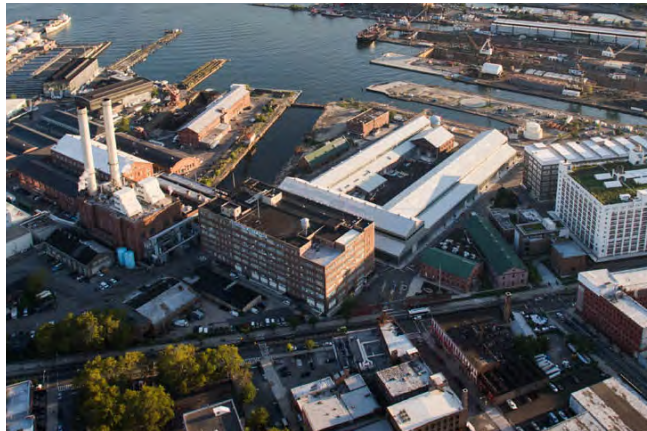

Infill (Brooklyn Navy Yards, New York)  
Strategic insertion of new buildings create high density employment space and catalyse refurbishment of industrial buildings in the area.

# 4 Typologies

## 4.1 Design Principles

### 4.1.6 Placemaking

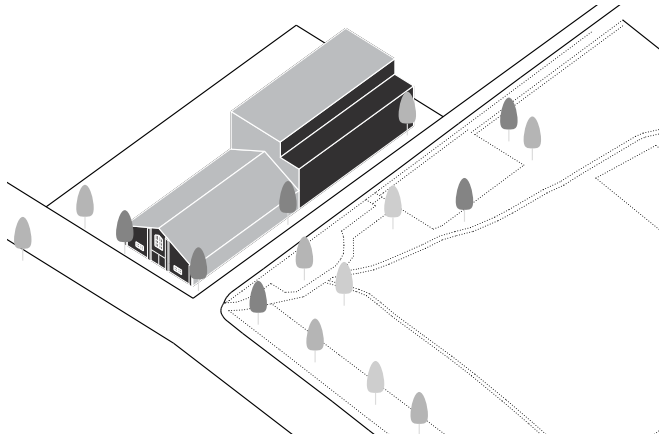

#### Design Principle 5: Placemaking

Attracting new occupiers to Park Royal will require strategies to improve the quality of the urban environment, such as improving the setting of existing heritage assets, creating positive street frontages and exploiting opens spaces.

#### Typical Applications

- Allow building to form boundary of sites, removing need for fences
- Improve the setting and quality of heritage buildings
- Exploit views and access to green spaces and the canal
- Ensure yards/access do not dominate the streetscape
- Minimise car parking or locate sensitively to ensure development has positive impact on the public realm
- Locate entrances to buildings directly on streets
- Locate yards and servicing at rear of sites



Existing condition  
The urban environment is dominated by fences and car parking.



Industrial fabric (Hackney Wick, London)  
Re-purposing older industrial buildings can create value through attracting creative industries to the area.



Exploit Amenity (Hackney Wick, London)  
Spaces such as the canal and existing green spaces can add value to adjacent developments and encourage a greater mix of uses.

# 4 Typologies

## 4.2 Case Studies

### 4.2.1 Willen Field Road

#### 4.2.1.1 Site Selection

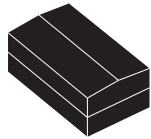

New Provision  
on Vacant Plot

Address 4-6 Willen Field Road  
Postcode NW10 7AQ  
PTAL 1a

Boundary Freehold  
Business-Site Type Vacant  
Building Type -  
Site Area 4,978 m<sup>2</sup>  
Footprint Site only

#### Development Summary

Total Development Value (GDV)	£ 23.2m
Total Development Cost	£ 18.4m
Residual Land Value (RLV)	£ 4.9m
Estimated Land Cost (EUV)	£ 3.4m
Viable	Yes

#### Site History

The site is currently vacant, with planning approval for proposed industrial/warehouse building with ancillary offices (flexible B1(c) / B2 / B8 uses) consisting of approx. 2,462 sqm GEA of warehouse, 309 sqm GEA of office.

#### Site Selection

The site sits between two existing standalone warehouses under the same ownership. The freehold was identified as having a low area efficiency due to the vacant plot.

This highlights an area of land unused for operational purposes. As the existing buildings in the same freehold are modern and of good quality, the vacant portion of the site is appropriate for development.

#### Development Objectives

Although the adjacent sites is under a single ownership, the existing buildings are considered to be of a high quality, and therefore the development will consider how a higher employment density can be achieved on the vacant plot beyond the density the approved scheme on the site.

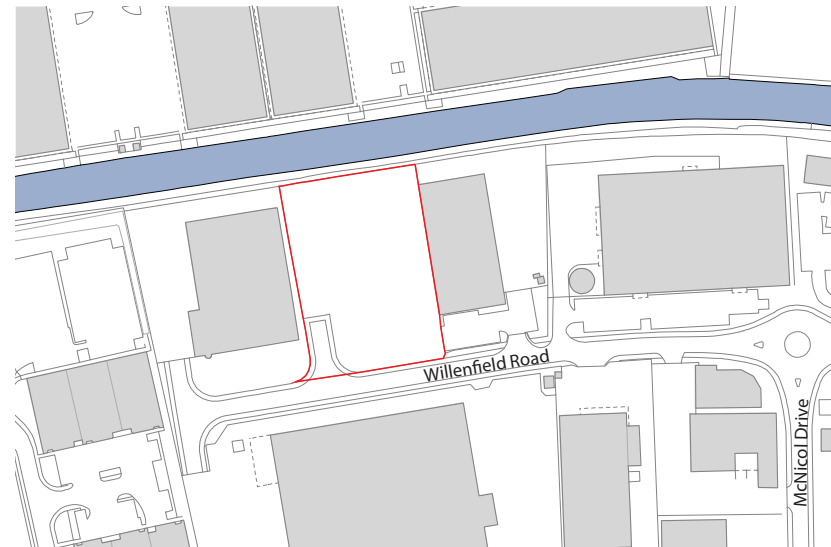
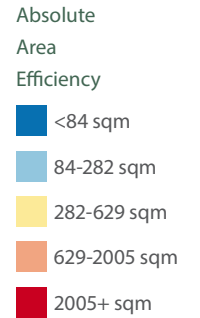
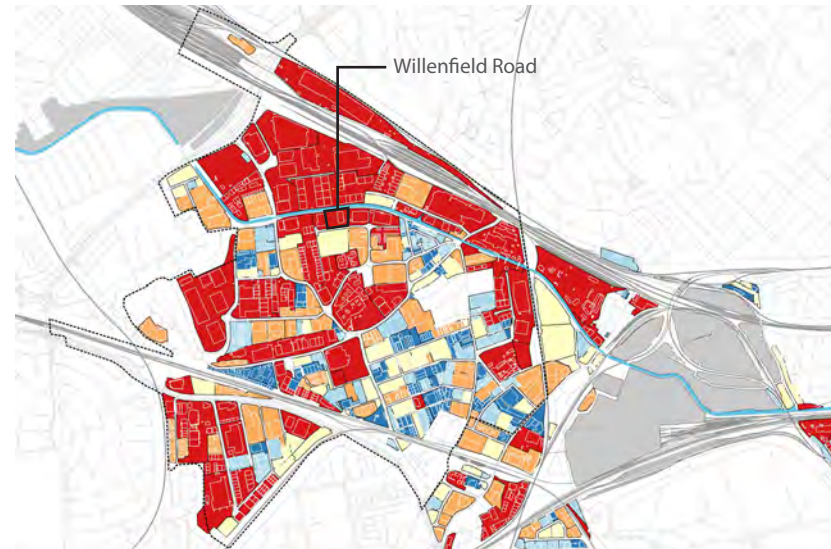

4 Typologies  
4.2 Case Studies  
4.2.1 Willen Field Road  
4.2.1.2 Existing Site



View from Willen Field Road  
The existing site looking to the north east.



View from Willen Field Road  
The existing site looking to the north west.

# 4 Typologies

## 4.2 Case Studies

### 4.2.1 Willen Field Road

#### 4.2.1.3 Mix and Space Requirements

Design Principle 1:  
Stack Uses

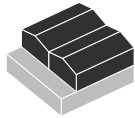

Design Principle 3:  
Separate Access

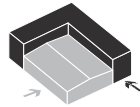

Design Principle 6:  
Placemaking

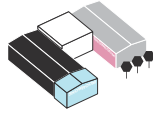

Use Class	Justification
B1a	Office space ancillary to industrial uses. Additional office space could exploit views and access to canal.
B1c	Combined with B1c, workshop/atelier typologies can exploit views and access to the canal, and good access for service vehicles.
B2/B8	Location suitable for industrial uses, but low PTAL is not suitable for other uses.

Typology	Justification
Medium Warehouse	Size and proportions of site suitable for medium-box industrial units
Workshop/ Atelier	Access for service vehicles can be exploited to maximise the capacity of the site with higher density workspace.
Small Office	Large site allows for separation of access to office

#### Typology Requirements

For spatial/operational requirements for each typology, please refer to appendix E.

	Key Design Considerations
Place making	The building should create a better frontage onto Willen Field, which is currently dominated by car parking and fences. The development should take advantage of the access and amenity of the canal to the north of the site.
Viability	In addition to the industrial nature of the surrounding area and low amenities, the low public transport accessibility level of this site contributes towards making the site challenging to attract B1 occupiers. Multi-storey industrial typologies could create opportunities to increase the total floor area achievable due to the size and shape of the site. However, intensification through adding additional storeys increases construction costs through requiring a more substantial structure and vertical circulation (lifts and ramps etc.).
Employment Density	Multi-storey industrial typologies can create a significant intensification of this land, and hence creating a potential uplift in job capacity.

# 4 Typologies

## 4.2 Case Studies

### 4.2.1 Willen Field Road

#### 4.2.1.4 Precedents



Stacked Industry (Theydon Road, Hackney)  
Smaller industrial units are stacked above larger units through the provision of a ramp serving multiple units at first floor level.



Canal Access (White Building, Hackney)  
Proximity to the canal can be exploited to create higher value workspace and improve amenity for workers.



Flatted Factories (London)  
Workspace can be located above workshops with access from yard space



Frontage  
Improved frontage by locating entrances on street and allowing building to form perimeter of site where possible.

# 4 Typologies

## 4.2 Case Studies

### 4.2.1 Willen Field Road

#### 4.2.1.5 Schematic Design

**Summary**  
 The design delivers high density employment space alongside multi storey industrial spaces, better relationship with the canal and amenity for employees.

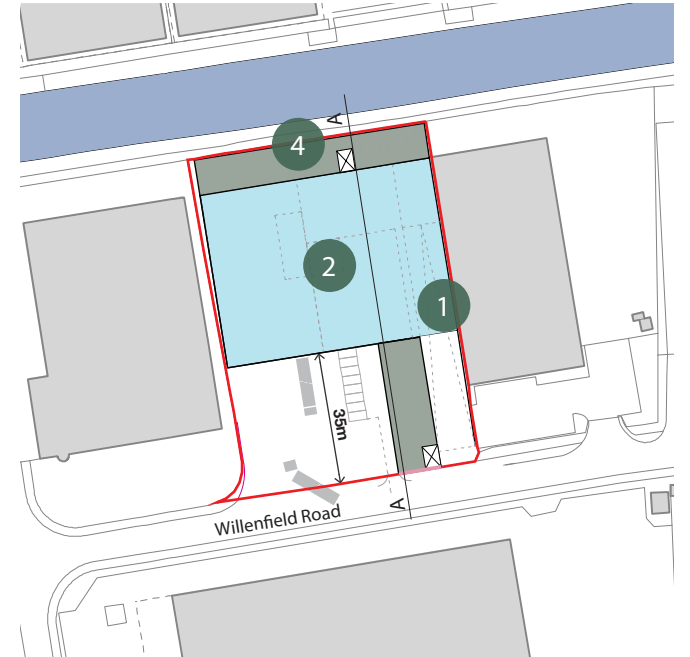
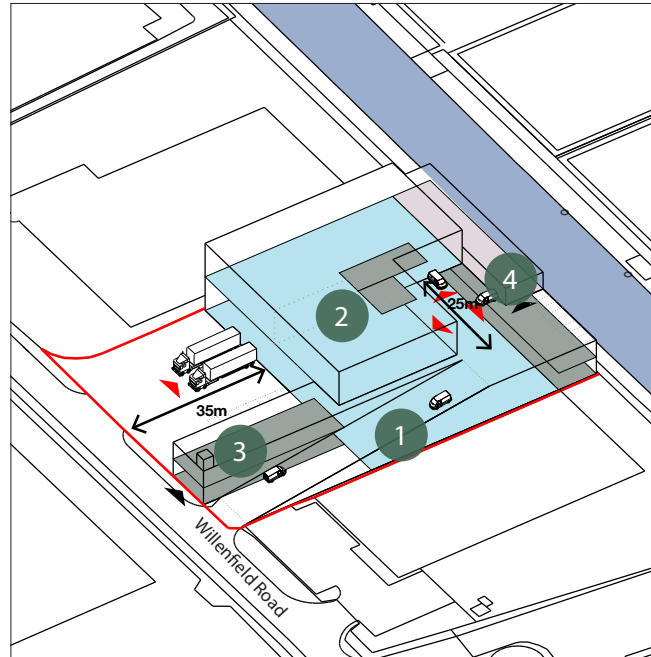
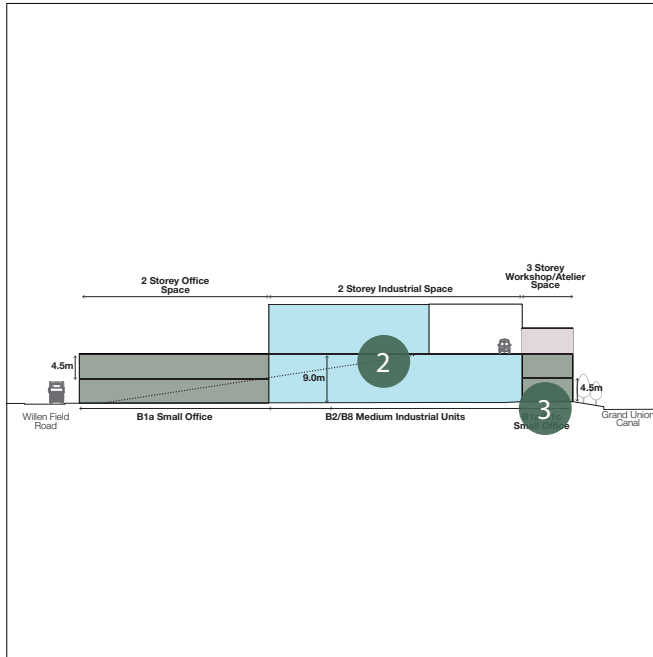

#### Approximate Existing Accommodation

Vacant site

#### Proposed Quantum of Development

B1a	2,116 m <sup>2</sup>	22,776 ft <sup>2</sup>
B1c	387 m <sup>2</sup>	4,466 ft <sup>2</sup>
B2/B8	4,735 m <sup>2</sup>	50,967 ft <sup>2</sup>

#### 1 Ramp

Ramp along eastern edge of site allows service vehicles to access first floor, creating the opportunity for multi-storey industrial space and giving access to northern edge of site next the canal.

#### 2 B2/B8 Medium Industrial Units

Industrial unit at ground floor with yard space accessed from Willen Field Road. Smaller industrial units with ancillary office space at first floor accessed via ramp, serviced by a yard suitable for smaller vans.

#### 3 Frontage

Entrance and B1a space ancillary to industrial unit provides frontage onto Willen Field Road.

#### 4 Workshop/Atelier

B1c/B1a building exploits views and access to the canal and footpath. B1c space has service access from yard accessed via ramp. Pedestrian access from Willen Field Road accommodated through office building at front of site.

# 4 Typologies

## 4.2 Case Studies

### 4.2.2 Gorst Road

#### 4.2.2.1 Site Selection

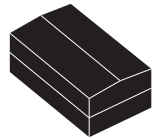

Comprehensive  
Redevelopment

Address 37 Gorst Road  
Postcode NW10 6LA  
PTAL 4

Boundary Freehold  
Business-Site Type Standalone Warehouse  
Building Type Large Industrial  
Site Area 3,847 m<sup>2</sup>  
Footprint 1,145 m<sup>2</sup>

#### Development Summary

Total Development Value (GDV)	£ 14.4m
Total Development Cost	£ 11.4m
Residual Land Value (RLV)	£ 3.1m
Estimated Land Cost (EUV)	£ 2.3m
Viable	Yes

#### Site History

Existing yard area appears to be unused by current occupier. We understand the site was recently the subject of an enquiry by Segro to buy the land.

The site which comprises 9,712 sq-ft of warehouse space and 3,232 sq-ft is currently to let.

#### Site Selection

The site is identified as having a poor spatial efficiency as a large proportion of the site is not in use for operational purposes. As such, the site is considered to have potential to deliver higher densities of employment on the site through a more efficient design utilising all land for operation.

#### Development Objectives

The size and proportion of the site, with road access on two sides makes larger industrial spaces potentially very efficient. The separation of uses would increase their marketability

The sites location and PTAL also offers an opportunity to incorporate office uses.

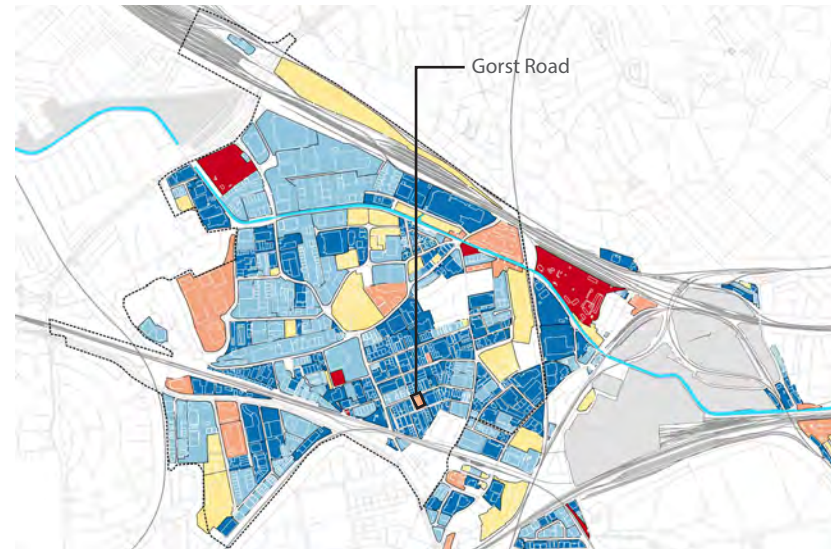

4 Typologies  
4.2 Case Studies  
4.2.2 Gorst Road  
4.2.2.2 Existing Site



View to south  
The existing site looking south from Gorst Road



Sunbeam Road  
Southern edge of site on Sunbeam Road

# 4 Typologies

## 4.2 Case Studies

### 4.2.2 Gorst Road

#### 4.2.2.3 Mix and Space Requirements

Design Principle 1:  
Stack Uses

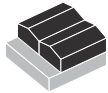

Design Principle 3:  
Separate Access

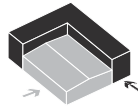

Design Principle 4:  
Exploit Accessibility



Design Principle 6:  
Placemaking

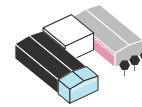

Use Class	Justification
B1a	PTAL and local amenity provide potential for attractive location for B1 uses ancillary to industrial uses on site.
B1c	Location and existing clusters of industries could be appropriate for flexible space for SMEs.
B2/B8	Good access from Gorst Road/Park Royal Road supports high quality industrial space.

Typology	Justification
Medium Warehouse	Access and size of site restricts larger industrial units, but size and proportions of plot can accommodate warehouses.
Studio/Workshop	Site access on three sides allows for servicing to smaller workspaces. Size could allow flexible units.
Small Office	Site access from three sites allows for dedicated access for offices, separate from industrial access.

Typology Requirements  
For spatial/operational requirements for each typology, please refer to appendix E.

	Key Design Considerations
Place making	Focussing B1 uses on Sunbeam Road could, combined with similar initiatives along the road create a positive environment on the route to North Acton Station
Viability	Although the site has a reasonable PTAL rating, the viability and therefore delivery of new B1 office space remains very challenging in isolation in this location due to the industrial nature of the surround area, low level of amenities and lack of existing offer. Demand from businesses remains overwhelmingly for industrial space where there is demand is viable to deliver.
Employment Density	Introducing higher employment densities at ground floor through B1c and provision of B1a space can exploit the location at good PTAL to provide an uplift in densities.

# 4 Typologies

## 4.2 Case Studies

### 4.2.2 Gorst Road

#### 4.2.2.4 Precedents



Workshop/Atelier (Spike Island, Bristol)  
Consolidation of B1 uses on certain streets can create positive environments, improving the marketability of multilevel B1 space



Kaap Nord  
Offices above workshops, with service access



Mezzanine  
Mezzanine levels provide significant increase in warehouse spaces.

# 4 Typologies

## 4.2 Case Studies

### 4.2.2 Gorst Road

#### 4.2.2.5 Schematic Design

**Summary**  
 The design delivers 260% increase of overall floorspace, creating a positive frontage onto Sunbeam Road

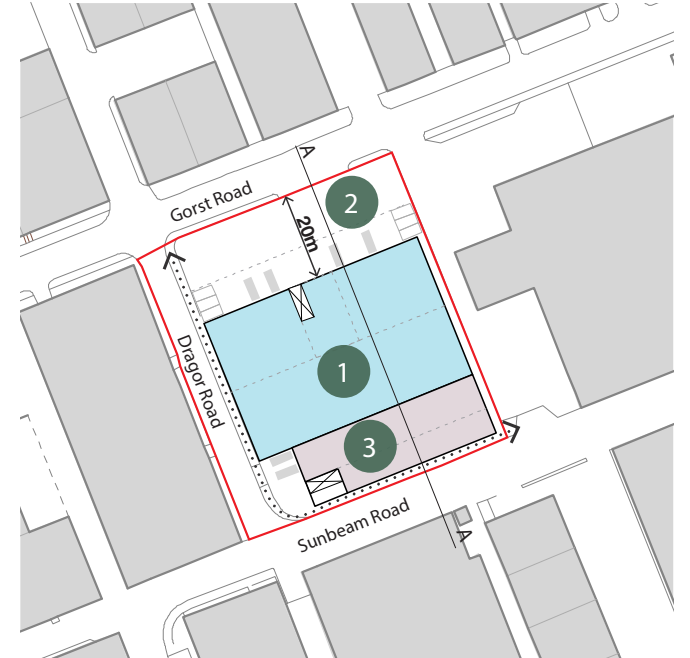
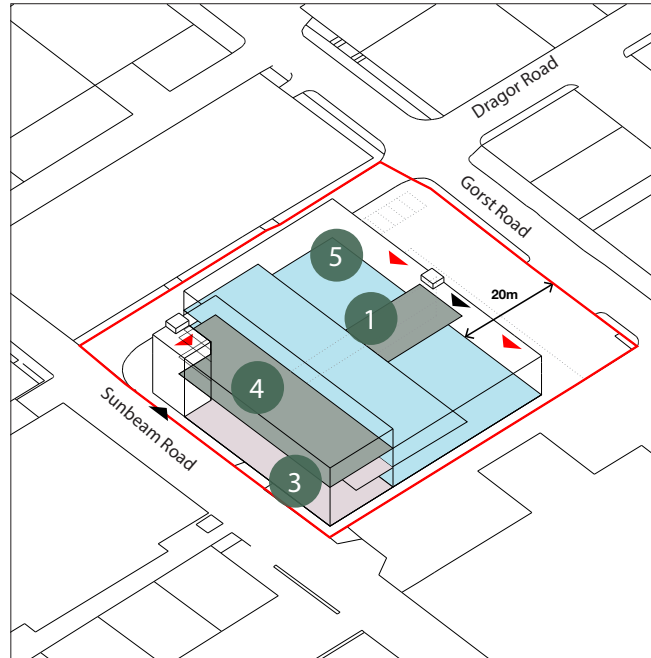
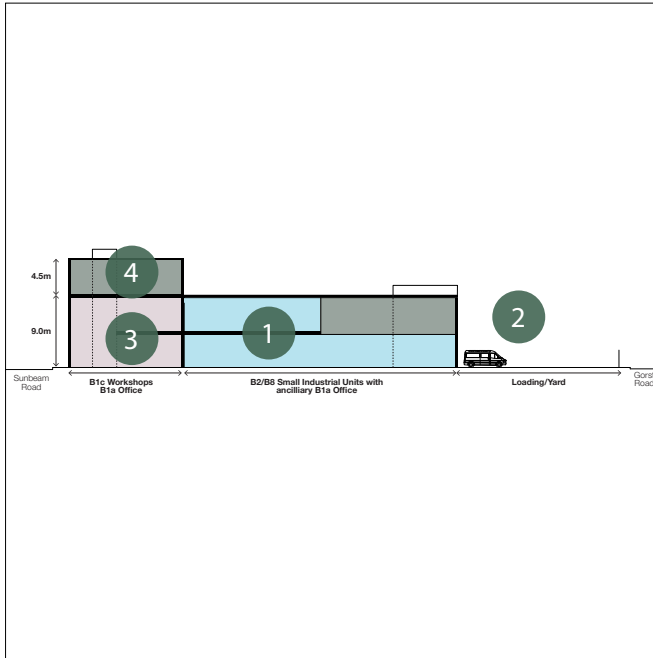
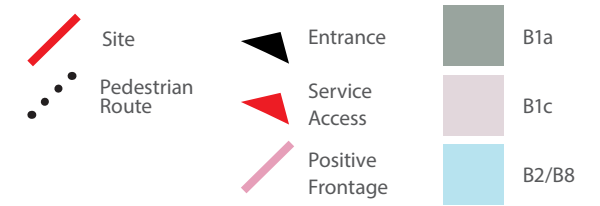

#### Approximate Existing Accommodation

B1a	300 m <sup>2</sup>	3,230 ft <sup>2</sup>
B2/B8	900 m <sup>2</sup>	9,700 ft <sup>2</sup>

#### Proposed Quantum of Development

B1a	642 m <sup>2</sup>	6,910 ft <sup>2</sup>
B1c	1,016 m <sup>2</sup>	10,936 ft <sup>2</sup>
B2/B8	2,680m <sup>2</sup>	28,847 ft <sup>2</sup>

**1 B2/B8 Industrial units with mezzanine**  
 Larger industrial uses located to north of site, where vehicular access from Park Royal Road is more direct. Small industrial units including mezzanine level, with consolidated office space.

**2 Loading**  
 20m deep service yard accessed via Gorst Road.

**3 Workshops/Atelier**  
 Ground floor B1c space with mezzanine level adding additional floor space but admitting light.

**4 Office Space**  
 Upper storeys support B1 uses with dedicated access off Sunbeam Road. Location of B1 uses takes advantage of most direct route to North Acton station.

# 4 Typologies

## 4.2 Case Studies

### 4.2.3 Waxlow Road

#### 4.2.3.1 Site Selection

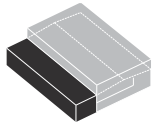

Horizontal Extension

Address	13 Waxlow Road
Postcode	NW10 7NU
PTAL	3
Boundary	Freehold
Business-Site Type	Standalone warehouse
Building Type	Large industrial
Site Area	2937m <sup>2</sup>
Footprint	812.62m <sup>2</sup>

#### Development Summary

Total Development Value (GDV)	£ 11.8m
Total Development Cost	£ 9.3m
Residual Land Value (RLV)	£ 2.8m
Estimated Land Cost (EUV)	£ 1.4m
Viable	Yes

#### Site History

Planning permission has been granted (15/5358) for a change of use of the coach depot site, which is currently Sui Generis into a use within the use classes B1c (light industry), B2 (general industry) or B8 (storage and distribution).

#### Site Selection

The site has been selected due to its low area efficiency as a large area is not utilised for operational purposes.

It is a good example of an older warehouse and yard along the canal that could be used more efficiently. There are a number of sites along the canal with similar characteristics.

#### Development Objectives

The existing function of the building is industry and storage (B8/B2). There is also an opportunity to add additional B1c and B1a to the site taking advantage of the canal-side amenity.

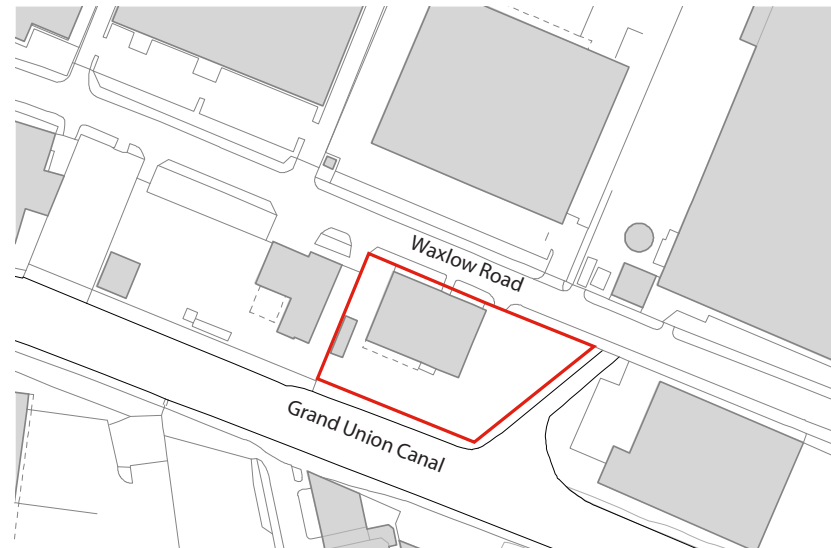
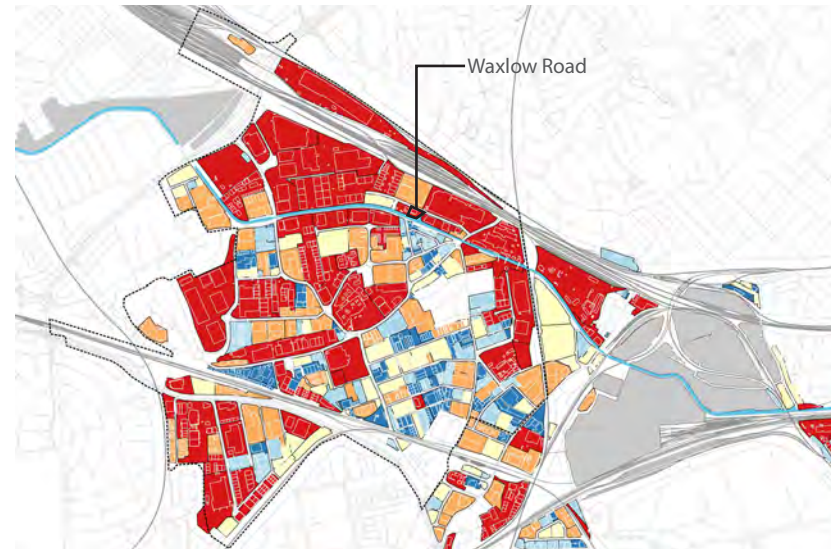

4 Typologies  
4.2 Case Studies  
4.2.3 Waxlow Road  
4.2.3.2 Existing site



Waxlow Road and Canal

The site has the canal on two sides with the Grand Union on the south and a smaller inlet on the eastern boundary. Waxlow Road is located on the north side.



Waxlow Road looking west

The existing brick warehouse building with yard space in the foreground.

# 4 Typologies

## 4.2 Case Studies

### 4.2.3 Waxlow Road

#### 4.2.3.3 Mix and Space Requirements

Design Principle 1:  
Stack Uses

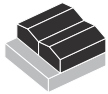

Design Principle 2:  
Shared Facilities

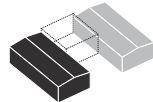

Design Principle 3:  
Separate Access

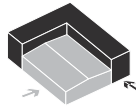

Design Principle 4:  
Exploit Location



Design Principle 6:  
Placemaking

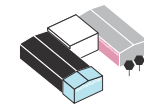

Use Class	Justification
B1a	PTAL and local amenity provide attractive location for B1 uses.
B1c	PTAL and separate access to Waxlow Road.
B2/B8	Continuation of existing site uses.

Typology	Justification
Small office	Separate entrance from Waxlow Road for pedestrians.
Studio/ workspace	With access to a dedicated loading area and yard space off Waxlow Road. Separate pedestrian entrance.
Small warehouse	Continuation of use of the existing building B2/B8.

Typology Requirements  
For spatial/operational requirements for each typology, please refer to appendix E.

	Key Design Considerations
Place making	Street presence is improved with the addition of workspace and office on Waxlow Road. The design makes the most of the canal side location providing amenity along the canal edge.
Viability	Space with views over the canal (amenity space) and proximity to public transport (accessibility) means Waxlow Road is likely to prove attractive to B1a office occupiers, much more so than other case study sites. This is likely to result in better rental values and interest from investors, and overall the site being more viable to deliver office space, albeit with other value generating employment uses such as industrial
Employment Density	Multi-storey typologies offer the opportunity to create space for higher density use classes, whilst maintaining industrial space on the ground floor.

4 Typologies  
4.2 Case Studies  
4.2.3 Waxlow Road  
4.2.3.4 Precedents



Regent's Canal, London  
Office space fronting onto the canal.



Woolwich, London  
Light industrial at ground level and offices/studios above.



Hackney Wick, London  
Outdoor space making the most of the canal side amenity.

# 4 Typologies

## 4.2 Case Studies

### 4.2.3 Waxlow Road

#### 4.2.3.5 Schematic Design

**Summary**  
 The design delivers higher density with the addition of new B1c workspace and B1a office while retaining the existing B2/B8 storage. Making the most of the canal side location, the scheme maximises amenity.

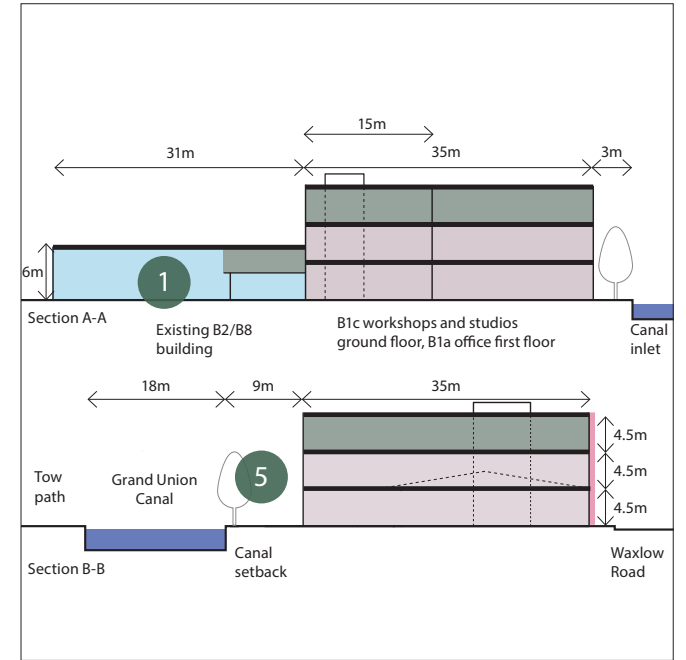
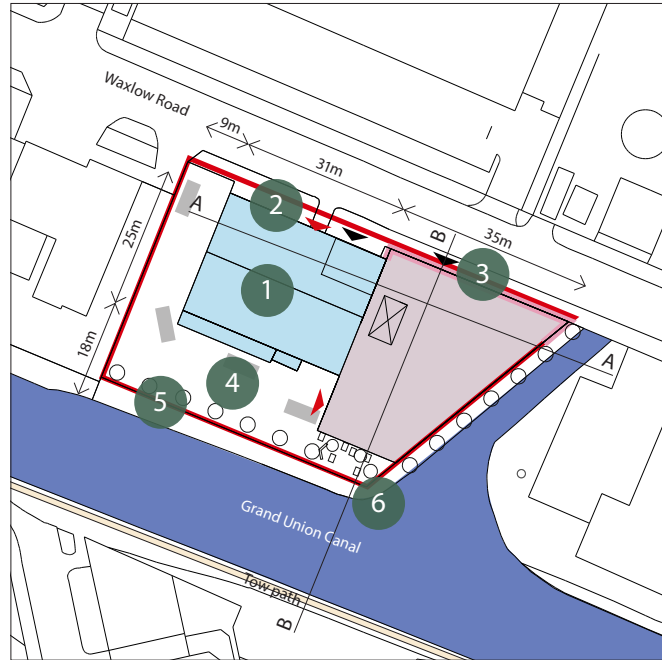
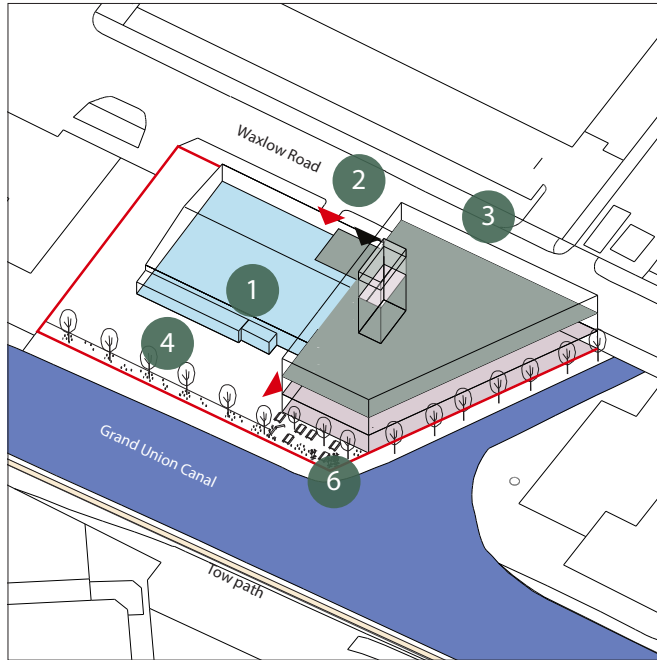
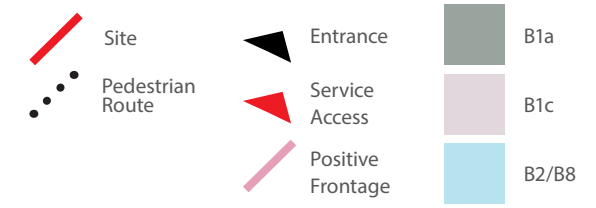

**Approximate Existing Accommodation**

812 m<sup>2</sup>      8,740 ft<sup>2</sup>

**Proposed Quantum of Development**

B1a	963 m <sup>2</sup>	10,365 ft <sup>2</sup>
B1c	1,786 m <sup>2</sup>	19,224 ft <sup>2</sup>
B2/B8	703 m <sup>2</sup>	7,567 ft <sup>2</sup>

- 1. Existing brick building**  
 The existing brick building is used for B2/B8 storage and is to be retained with the addition of an internal mezzanine for office uses (B1a).
- 2. Vehicle entry to existing building**  
 Entry to the existing building will be maintained.
- 3. Separate entrance for pedestrians to new B1a space**  
 Entry from Waxlow Road for pedestrians to reception area on ground floor. A lift connects the entrance foyer with the upper B1a storeys.

- 4. Yard space**  
 Accessible from Waxlow Road with loading access for B1c.
- 5. Canal setback**  
 All development has been setback from the canal to allow access.
- 5. Canal side outdoor area**  
 Amenity area next to the canal with seating and planting.

# 4 Typologies

## 4.2 Case Studies

### 4.2.4 North Acton Road

#### 4.2.4.1 Site Selection

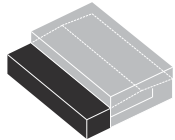

Horizontal Extension

Address 37-39 North Acton Road  
 Postcode NW10 6PF  
 PTAL 4

Boundary Freehold  
 Business Packaging company  
 Site Type Industrial Estate  
 Building Type Large Industrial  
 Site Area 5,945 m<sup>2</sup>  
 Footprint 2,004 m<sup>2</sup>

#### Development Summary

Total Development Value (GDV)	£ 26.7m
Total Development Cost	£ 21.2m
Residual Land Value (RLV)	£ 5.2m
Estimated Land Cost (EUV)	£ 3m
Viable	Yes

#### Site History

Currently occupied by owner occupier using the site for wholesale.

No relevant planning history.

#### Site Selection

The site is identified as having a low area efficiency as a large proportion of the site is not used for operational purposes.

The potential to intensify the site is further justified by its location and resultant PTAL which could support the addition of other uses.

#### Development Objectives

The sites location and proximity to Harlesden station and amenity space makes workspace on the site potentially desirable.

The existing building on North Acton Road has heritage quality and could therefore be attractive to come occupiers. Partial demolition and redevelopment could make the site coverage more efficient.

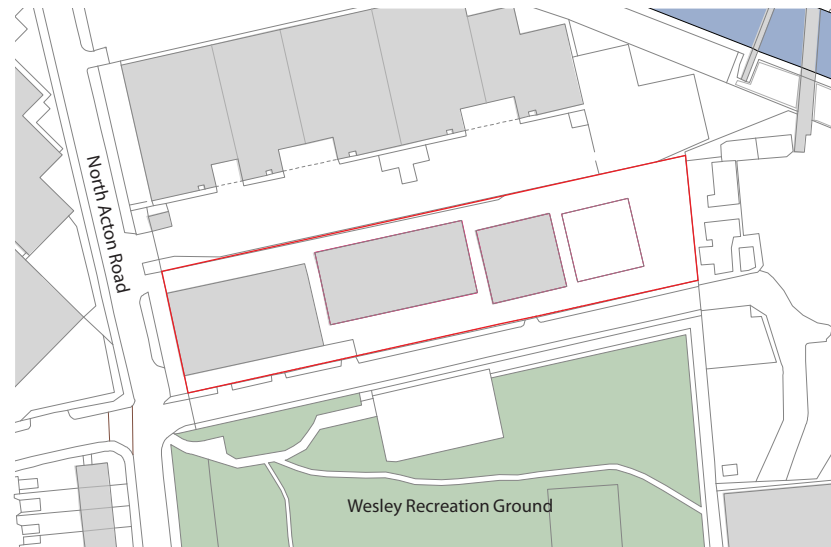
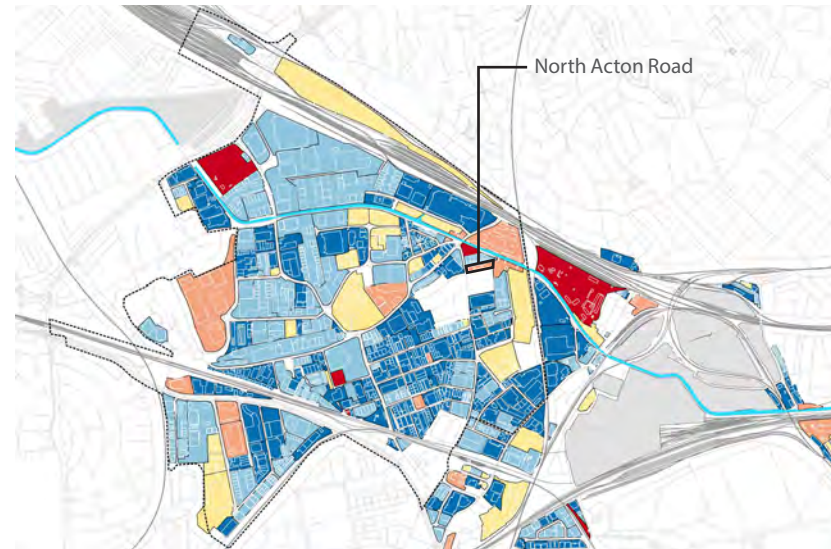

4 Typologies  
4.2 Case Studies  
4.2.4 North Acton Road  
4.2.4.2 Existing Site



View to south  
Existing warehouse on North Acton Road



Sunbeam Road  
Access Road to south of site, along north edge of Wesley Recreation ground

# 4 Typologies

## 4.2 Case Studies

### 4.2.4 North Acton Road

#### 4.2.4.3 Mix and Space Requirements

Design Principle 1:  
Stack Uses

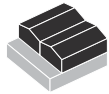

Design Principle 3:  
Separate Access

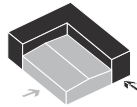

Design Principle 4:  
Exploit Accessibility

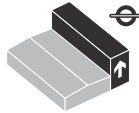

Design Principle 6:  
Placemaking

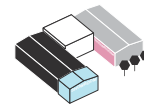

Use Class	Justification
B1a	PTAL and local open space amenity provide potential for attractive location for B1 uses.
B1c	Potential for additional workspace without loading/yard through horizontal extension or internal subdivision
B2/B8	Partial demolition would allow for provision of larger industrial units.

Typology	Justification
Small Warehouse	Access and size of site restricts larger industrial units, but size and proportions of plot can accommodate warehouses through partial demolition
Studio/ Workshop	Infill development could accommodate artisan manufacturing/ateliers.
Small Office	Infill development offers potential for entrances separate from industrial spaces

Typology Requirements  
For spatial/operational requirements for each typology, please refer to Appendix E.

	Key Design Considerations
Place making	The existing assets of the existing warehouse on North Acton Lane and the Wesley Recreation ground should be exploited. A positive frontage should be created on the south and west boundaries of the site.
Viability	Values for B1a space in this location limit the extent of viable refurbishment to minor improvements and single storey horizontal extension. Key value drivers remains industrial as a good proportion of floor space.
Employment Density	Introducing higher employment densities at ground floor through B1c and provision of B1a space can exploit the location to provide an uplift in densities.

4 Typologies  
4.2 Case Studies  
4.2.4 North Acton Road  
4.2.4.4 Precedents



Brooklyn Navy Yards, Brooklyn  
Internal subdivision could incorporate higher grade industrial space in heritage building.



Hôtel Industriel, in Bois-de-Bay, Satigny  
Small industrial units along with studio/workshop spaces.

# 4 Typologies

## 4.2 Case Studies

### 4.2.4 North Acton Road

#### 4.2.4.5 Schematic Design

**Summary**  
 The design delivers 330% increase of overall floorspace, creating a positive frontage onto North Acton Road and Wesley Recreation Ground, maximising amenity for workers.

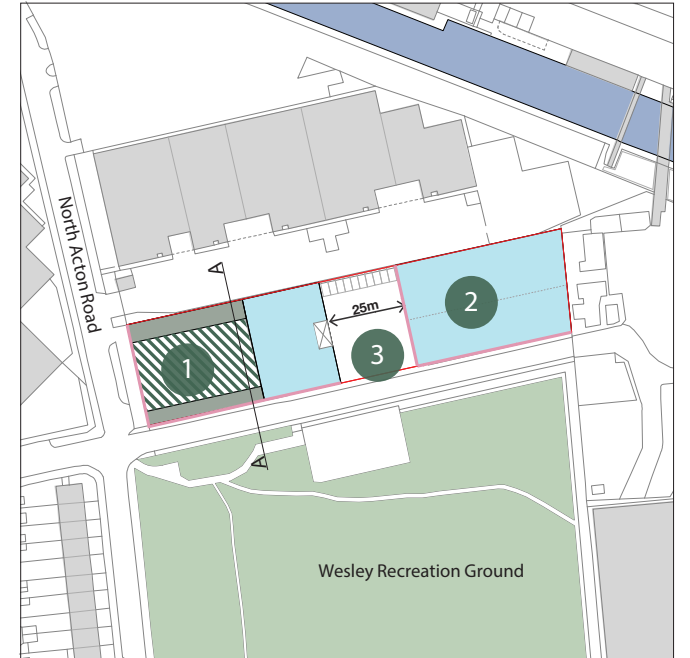
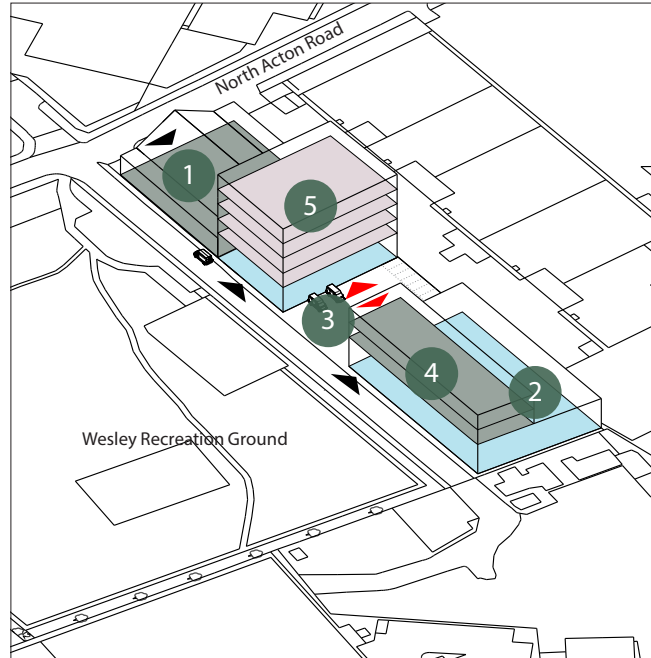
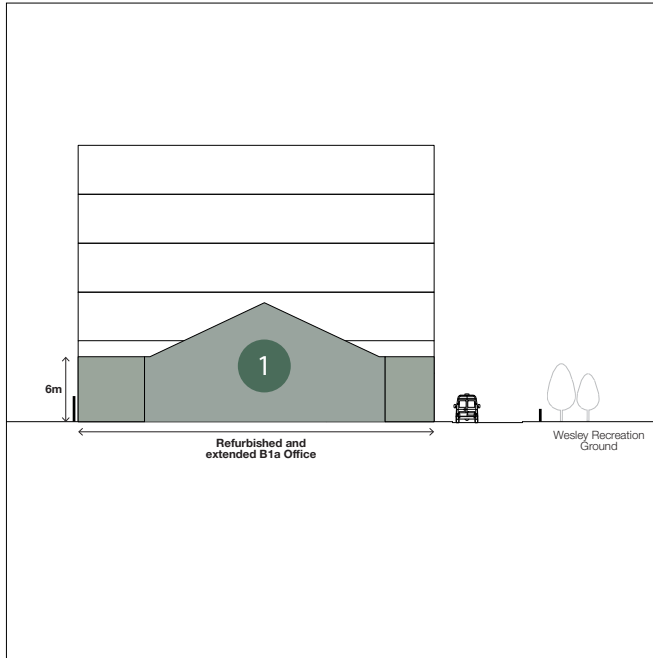

**Approximate Existing Accommodation**

2,004 m<sup>2</sup>      21,561 ft<sup>2</sup>

**Proposed Quantum of Development**

B1a	2,769 m <sup>2</sup>	29,805 ft <sup>2</sup>
B1c	3,292 m <sup>2</sup>	35,434 ft <sup>2</sup>
B2/B8	2,547 m <sup>2</sup>	27,415 ft <sup>2</sup>

- 1 Retain Warehouse Building**  
Existing warehouse building retained with single storey extension to the north and south. Building refurbished and use changed to B1a.
- 2 B2/B8 Medium Industrial Unit**  
Medium sized industrial warehouse serviced from shared yard.
- 3 Create Shared Yard**  
Yard space services new B1c and B2/B8 small industrial units. Yard dimensioned to accommodate transit vehicles.

- 4 Office Space**  
Ancillary office plus additional space exploits views over Wesley Recreation ground to the south.
- 5 Goods Lift**  
B1c space on upper storeys serviced via shared goods lift.

# 4 Typologies

## 4.2 Case Studies

### 4.2.5 Victoria Road

#### 4.2.5.1 Site Selection

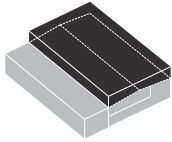

Vertical Extension/  
Infill

Address 97 Victoria Road  
Postcode NW10 6SX  
PTAL 4

Boundary Freehold  
Business Vehicle maintenance  
Site Type Industrial Estate  
Building Type Large Industrial  
Site Area 3,719 m<sup>2</sup>  
Footprint 1,974 m<sup>2</sup>

#### Development Summary

Total Development Value (GDV)	£ 28.6m
Total Development Cost	£ 22.7m
Residual Land Value (RLV)	£ 5.9m
Estimated Land Cost (EUV)	£ 3m
Viable	Yes

#### Site History

The site is currently let on a 15-year lease at £239,430 pa. The tenant has permission to build a mezzanine floor (1,500sqft) and will make capital contribution to this refurbishment. A planning application for the construction of an extension to the front/eastern elevation of the warehouse has been granted with conditions by LB Ealing.

#### Site Selection

The site has been selected due to its low FAR of 0.55, which means the quantum of development on the site can be significantly increased.

It has good accessibility with a PTAL of 4 and is five minutes walk from North Acton station. It has been identified as suitable for intensification through vertical extension and additional infill development. The site is an exemplar of a number of similar sites in the study area with warehouses and yards that are constrained and have limited access.

#### Development Objectives

A new building is proposed that contains space for the existing storage and industrial functions (B2/B8) and also adds new workspace (B1c) and office (B1a) functions. The B2/B8 will have 9m floor to ceiling height and level access to the yard and loading area. New workspace and studios (B1c) above the B2/B8 will have access to the yard via the goods lift. New office space will take advantage of the site's accessibility to public transport and improve the Victoria Road Street presence.

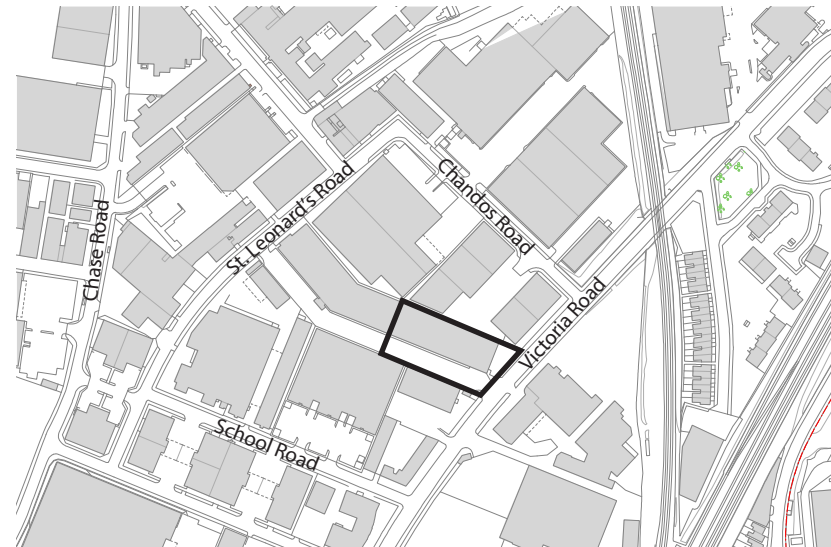

4 Typologies  
4.2 Case Studies  
4.2.5 Victoria Road  
4.2.5.2 Existing site



View from Victoria Road  
The existing building used for storage with yard space in-front.



Yard space  
View on site looking South towards Victoria Road of the existing yard used for parking.



Existing building  
The existing warehouse space is used for storage.

# 4 Typologies

## 4.2 Case Studies

### 4.2.5 Victoria Road

#### 4.2.5.3 Mix and Space Requirements

Design Principle 1:  
Stack Uses

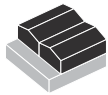

Design Principle 2:  
Shared Facilities

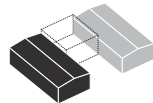

Design Principle 3:  
Separate Access

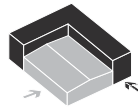

Design Principle 4:  
Exploit Location



Use Class	Justification
B1a	PTAL and local amenity provide potential for attractive location for B1 uses.
B1c	Location and existing clusters of industries could be appropriate for SMEs.
B2/8	Current use of site and possibility for small scale manufacturing.

Typology	Justification
Medium to large office	Site access offers potential for dedicated office entrance and address on Victoria Road.
Small Office	Workspace typologies not requiring loading bays suitable for accommodation on upper floors.
Warehouse/ Industrial space with loading access	Access from Victoria Road can be maintained as well as yard space for loading.

#### Typology Requirements

For spatial/operational requirements for each typology, please refer to appendix E.

	Key Design Considerations
Place making	The addition of new workspace and office functions as well as the improved street frontage.
Viability	Although still challenging to deliver new space viably, the site location of Victoria Road is likely to be prove more attractive to B1 office occupiers than some other study sites due to higher transport accessibility (close to North Acton station) and proximity to the future redevelopment of the Old Oak Common area. Separation of uses between frontage onto Victoria Road and rear of site should ensure space is more marketable.
Employment Density	Multi-storey office and light industrial space has potential to provide significant uplift in employment densities.

4 Typologies  
4.2 Case Studies  
4.2.5 Victoria Road  
4.2.5.4 Precedents



Workspace and loading space, Amsterdam  
A combination of workspace, offices and loading space in North Amsterdam.



Workspace, Munich  
A example of multi-level workshops, this Gewerbehöfe is built by the city of Munich providing workshops for local industries and studio space.

# 4 Typologies

## 4.2 Case Studies

### 4.2.5 Victoria Road

#### 4.2.5.5 Schematic Design

**Summary**  
 The design improves street presence, increases the overall development on site by 350%, retains the existing land-use (B2/B8) and adds the new functions of workspace, studios (B1c) and office (B1a)

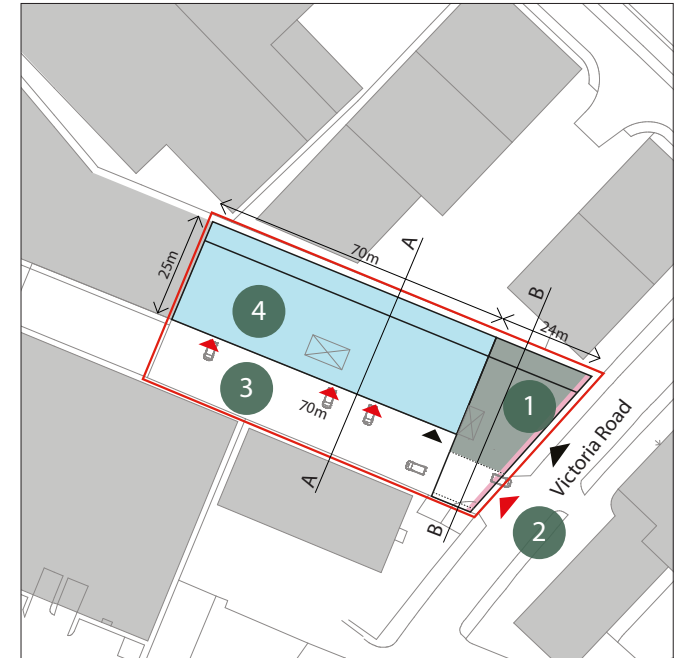
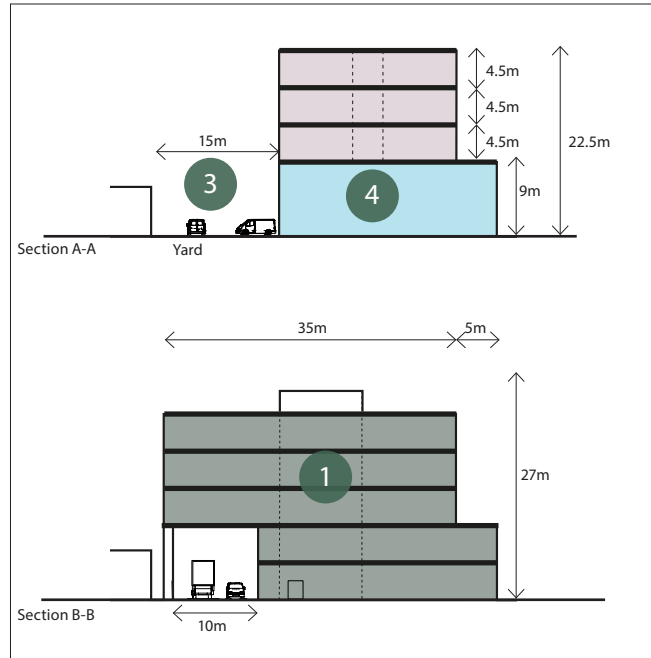
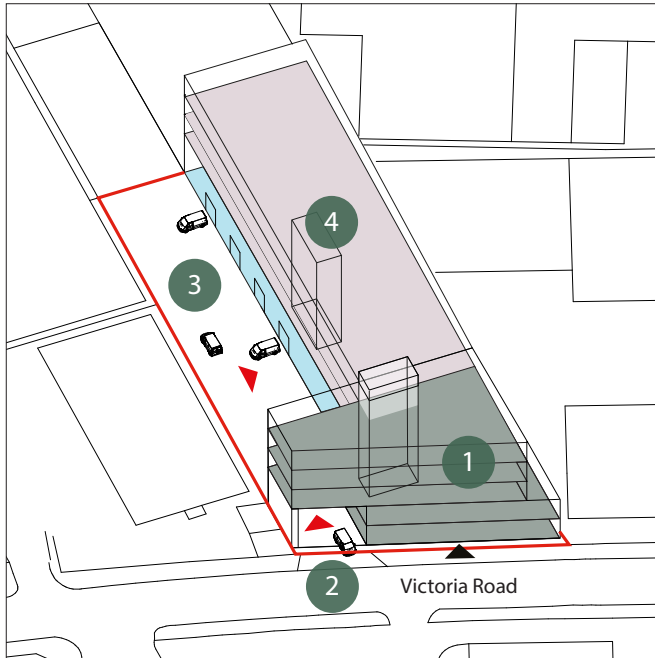
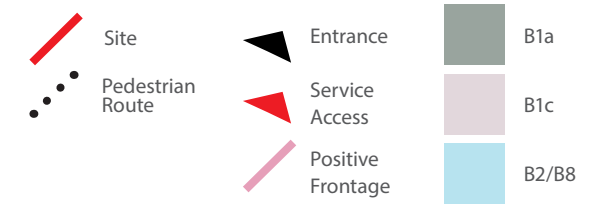

**Approximate Existing Accommodation**

1,974 m<sup>2</sup>      21,248 ft<sup>2</sup>

**Proposed Quantum of Development**

B1a	2,771 m <sup>2</sup>	29,827 ft <sup>2</sup>
B1c	4,323 m <sup>2</sup>	46,532 ft <sup>2</sup>
B2/B8	1,750 m <sup>2</sup>	18,837 ft <sup>2</sup>

- 1. New office building**  
 The new office building provides street presence, as well as a direct pedestrian entrance from Victoria Road.
- 2. Vehicle entrance**  
 Vehicle access to the loading yard from Victoria Road is maintained.

- 3. Loading yard**  
 The area for loading is maintained.
- 4. Building with B1c and B2/B8**  
 A new building with three upper floors of light industrial accessed by the goods lift and storage and industrial uses on the ground floor.

# 4 Typologies

## 4.2 Case Studies

### 4.2.6 Minerva Road

#### 4.2.6.1 Site Selection

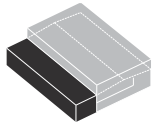

Phased  
Comprehensive  
Redevelopment

Address 32-36 & 38-42 Minerva Rd  
Postcode NW10 6HJ  
PTAL 3

Boundary Site  
Business Vehicle maintenance  
Site Type Dense industrial & vacant lot  
Building Type Large industrial & yard  
Site Area 7,868m<sup>2</sup>  
Footprint 1,939m<sup>2</sup>

#### Development Summary

Total Development Value (GDV)	£ 45.3m
Total Development Cost	£ 35.6m
Residual Land Value (RLV)	£ 7.1m
Estimated Land Cost (EUV)	£ 2.9m
Viable	Yes

#### Site History

No relevant planning history.

#### Site Selection

The site comprises of two consolidated pieces of land. These are 38-42 Minerva Road that contains a warehouse with yard space and 32-36 Minerva Road, a vacant lot used for storage. The site is a useful case study since its scale and size is representative of other dense industrial locations in Park Royal. There is an opportunity to develop with a phased approach as both sites have the same land owner. The first phase would be a new development on the vacant lot and the second a comprehensive redevelopment of the existing warehouse building.

#### Development Objectives

A phased comprehensive development is planned for the site. In phase one a new building would be constructed on the existing vacant lot adding additional B2/B8 as well as new office (B1a) along Minerva Road and flexible B1c workspace for SMEs. The existing warehouse would remain as B8/B2. In phase two the existing warehouse would be demolished and a second building constructed with a mix of B2/B8 on the ground floor and B2c workspace above. Both would have access to a shared yard space for loading. The frontage along Minerva Road would be enhanced with additional office space constructed.

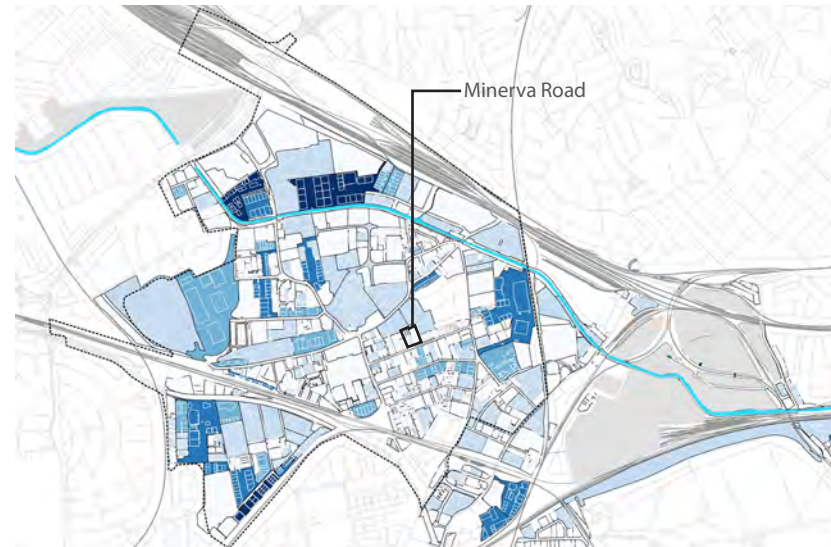

4 Typologies  
4.2 Case Studies  
4.2.6 Minerva Road  
4.2.6.2 Existing site



Existing warehouse  
The existing warehouse frontage onto Minerva Road. Part of the warehouse is setback from the road and used for loading and parking.



View along Minerva Road  
Minerva road with vacant site on the right and the existing warehouse in the background.

# 4 Typologies

## 4.2 Case Studies

### 4.2.6 Minerva Road

#### 4.2.6.3 Mix and Space Requirements

Design Principle 1:  
Stack Uses



Design Principle 2:  
Shared Facilities

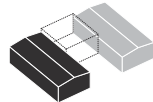

Design Principle 3:  
Separate Access

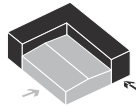

Design Principle 4:  
Exploit Location



Use Class	Justification
B1(a)	Relation to existing clusters and potential new SME's.
B1(c)	Existing clusters of industries could be appropriate for flexible space and SME's.
B2/B8	The site is now used for storage/distribution. Possibility for the addition of small scale manufacturing.

Typology	Justification
Medium to large office	Site access offers dedicated office entrance and address on Minerva Road.
Studio/workshop	New workspace that could be serviced by light vehicles as well as a loading yard.
Medium warehouse	Size of site and potential phasing of development. Access from Minerva Road, which is more suited to light and medium goods vehicles rather than HGVs.

Typology Requirements  
For spatial/operational requirements for each typology, please refer to appendix E.

	Key Design Considerations
Place making	Improved street presence along Minerva Road with visible studio and flexible B1c space at street level as well as the introduction of additional B1(a) commercial space and an increase in B2/8.
Viability	Consolidating access for B1a office uses separately from industrial space and locating these directly fronting the street is likely to increase their appeal to occupiers. Limiting height to two storeys ensures a balance between sales area and construction costs.
Employment Density	Incorporating B1 uses with B2/B8 will provide space for higher density employment on the site.

4 Typologies  
4.2 Case Studies  
4.2.6 Minerva Road  
4.2.6.4 Precedents



Shared yard, London  
Industrial units with a shared yard and loading space



Street presence, Manchester  
Workspace with strong positive street presence.



Ada Street Workshops, London  
Multi level work spaces accommodating a range of work and studio functions in Hackney.

# 4 Typologies

## 4.2 Case Studies

### 4.2.6 Minerva Road

#### 4.2.6.5 Schematic Design

**Summary**  
 A phased development that provides a significant amount of new workspace and improves the street presence along Minerva Road.

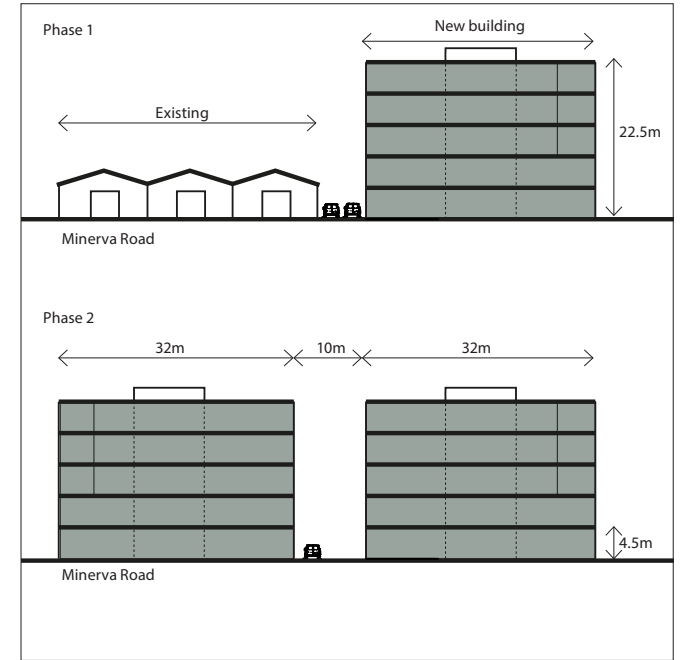
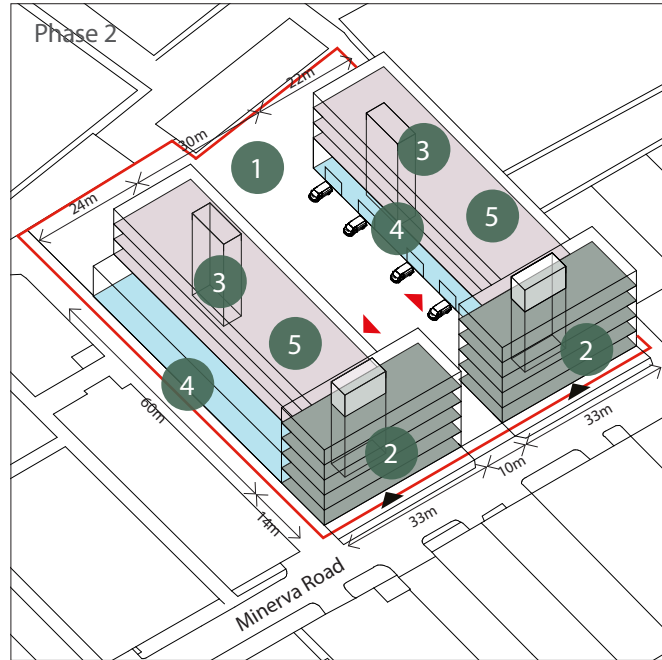
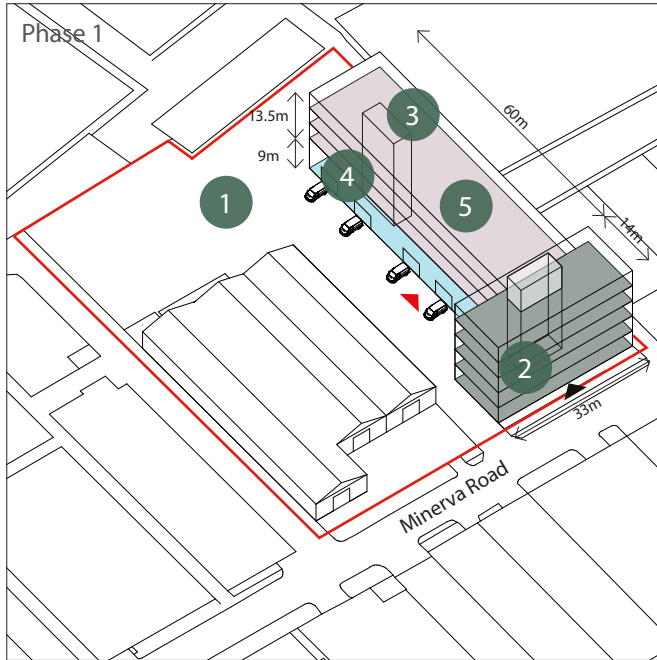
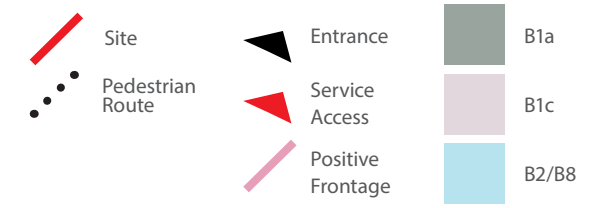

Approximate Existing Accommodation		
B2/B8	1,939 m <sup>2</sup>	21,097 ft <sup>2</sup>
Proposed Quantum of Development		
B1a	4,570 m <sup>2</sup>	49,191 ft <sup>2</sup>
B1c	6,402 m <sup>2</sup>	68,910 ft <sup>2</sup>
B2/B8	2,749 m <sup>2</sup>	29,590 ft <sup>2</sup>
Overall Viability Position      Viable		
Surplus/Deficit		£ 4,194,000

- 1. Yard  
 Yard space is provided for B2/B8 and B1c uses with access from Minerva Road. Loading would be for light vehicles and is not intended for HGV's.
- 2. B1 entrances  
 The office buildings have their entrances on Minerva Road providing street presence.
- 3. Good lift  
 Goods lifts connect the B1c with the yards.

- 4. B8/B2  
 B2/B8 location on ground floor with direct access to yard/loading area and 9m clear height. A range of companies could be accommodated.
- 5. B1c  
 Would be able to accommodate a range of SME's with different sizes of space and access to the yard by goods lift.

# 4 Typologies

## 4.2 Case Studies

### 4.2.7 Bashley Road

#### 4.2.7.1 Site Selection

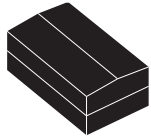

New Build on vacant land

Address Bashley Road, Volt Ave.  
 Postcode -  
 PTAL 1b

Boundary Site  
 Business-Site Type Vacant land  
 Building Type Site only  
 Site Area 10,594 m<sup>2</sup>  
 Footprint Site only

#### Development Summary

Total Development Value (GDV)	£ 37.8m
Total Development Cost	£ 29.9m
Residual Land Value (RLV)	£ 13.6m
Estimated Land Cost (EUV)	£ 7.2m
Viable	Yes

#### Site History

Owned by Inco Europe, the land is adjoining the Vale Acton - Precious Metal Refinery. The site is surrounded by the Acton Refinery to the west, the Powergate Business Park to the north, the Ealing Travellers Site to the east and the Chandos Park Industrial Estate to the south.

#### Site Selection

Given its current vacancy, the site is identified and highlighted by most indicators, as suitable for intensification, as it shows a low FAR, low area or volume efficiencies. This condition makes it appropriate for new built intensive developments.

#### Development Objectives

Its current accessibility conditions makes the location suitable for medium sized warehouses.

Development of HS2 construction sites in Channel Gate as Industrial Innovation District and an improved links to Old Oak could bring a demand for increased employment densities in the future.

Comprehensive development option including the Vale Acton - Precious Metal Refinery demonstrates the development potential of a larger site (see options A and B in this chapter).

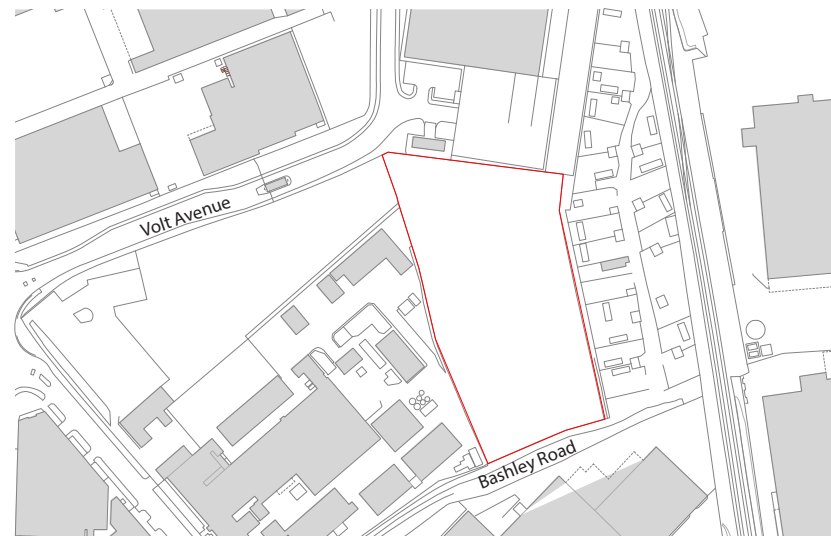
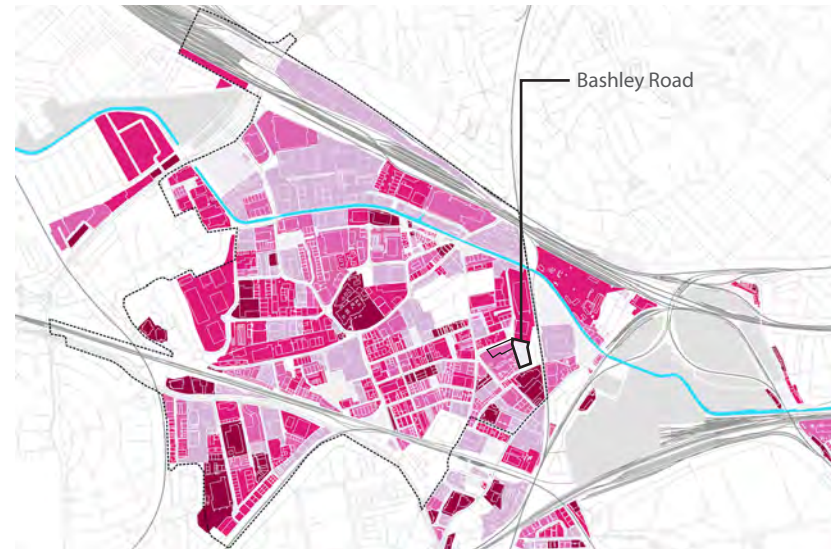

# 4 Typologies

## 4.2 Case Studies

### 4.2.7 Bashley Road

#### 4.2.7.2 Existing Site

1\ Adjacency to Acton Refinery  
Site is compromised by the activities of the adjacent industrial buildings

2\ Entrance from Bashley Road  
The only entrance to the site at the moment is from Bashley Road.



3\ Entrance from Volt Avenue  
Although the site could be accessed from Volt Avenue, this entrance is currently controlled by a checkpoint. A new entrance on this site would need to be agreed with adjacent landowners

4\ Access to West  
Site to west is under same ownership, and a new route could be achieved through the existing car park.



# 4 Typologies

## 4.2 Case Studies

### 4.2.7 Bashley Road

#### 4.2.7.3 Mix and Space Requirements

Design Principle 1:  
Stack Uses

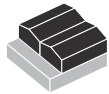

Design Principle 2:  
Share Facilities

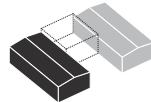

Design Principle 3:  
Separate Access

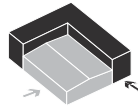

Use Class	Justification
B1a	Provision of office space as ancillary to the built warehouse area
B2/B8	Location also suitable for small and medium scale manufacturing

Typology	Justification
Small Office	Provision within industrial units, serving the needs of on site businesses.
Small Industrial	High enough to allow internal subdivisions and mezzanines where applicable
Medium Industrial	Size and proportion of site could allocate medium sized warehouse units with enough yard space for medium sized transport vehicles.

Typology Requirements  
For spatial/operational requirements for each typology, please refer to appendix E.

	Key Design Considerations
Place making	Site should respect the adjacency to traveller site to the east. Office uses should be positioned close to site access.
Viability	Due to its location B1a office uses will be challenging on this site beyond ancillary office space within industrial. Multi-level industrial typologies are feasible due to the good size of this site, but should keep HGV access to ground floor with access for light vehicles on upper floors to service 'last mile' operations.
Employment Density	As B1 uses are inappropriate in this location in large quantities, the approach should create an intense provision of industrial space, and hence multi-storey typologies should be considered to increase employment density.

# 4 Typologies

## 4.2 Case Studies

### 4.2.7 Bashley Road

#### 4.2.7.4 Precedents



Stacked Industry (Theydon Road, Hackney)  
Smaller industrial units are stacked above larger units through the provision of a ramp serving multiple units at first floor level.

Belartza, Donostia-San Sebastian  
The stacking of smaller industrial types on upper floors enables a tighter site planning of ramps



Multi-storey warehousing (X2, Heathrow)  
Vehicles access service yards on upper storeys via vehicle ramp

# 4 Typologies

## 4.2 Case Studies

### 4.2.7 Bashley Road

#### 4.2.7.5 Schematic Design

**Summary**  
 The design delivers a new mixture of large industrial and smaller industrial typologies through provision of a ramp for service vehicles.

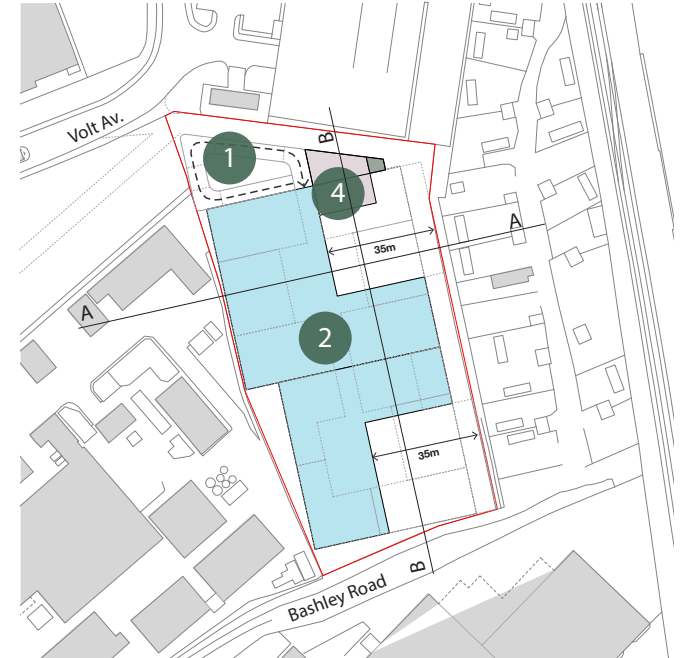
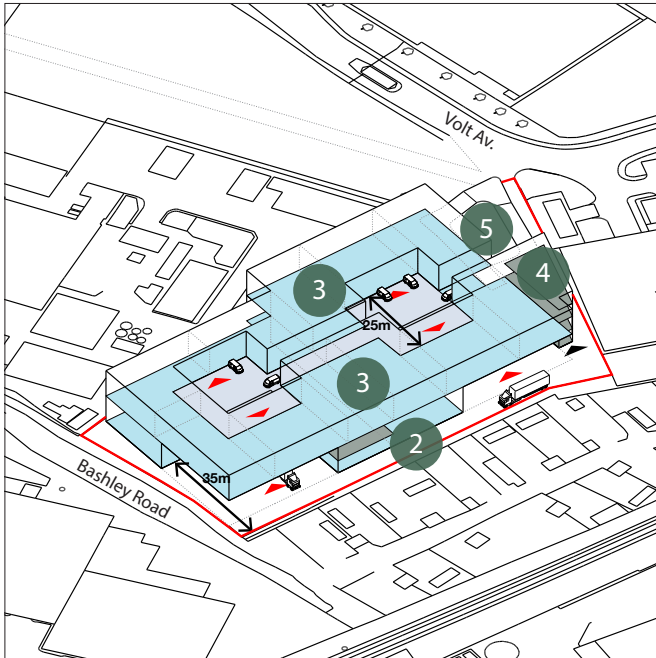
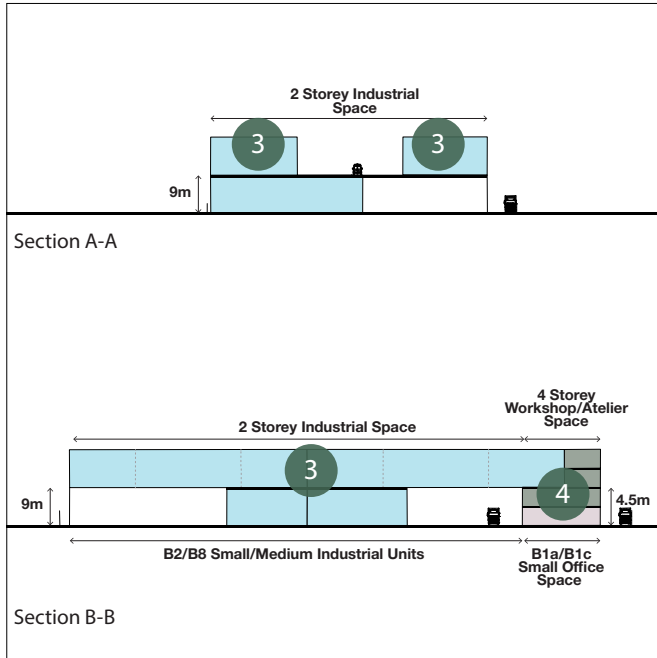

Approximate Existing Accommodation  
 Vacant site

Proposed Quantum of Development

B1a	801 m <sup>2</sup>	8,621 ft <sup>2</sup>
B1c	363 m <sup>2</sup>	3,907 ft <sup>2</sup>
B2/B8	10,381 m <sup>2</sup>	111,740 ft <sup>2</sup>

- 1 Ramp  
Ramp provides access to industrial units at first floor for 7.5 tonne vehicles
- 2 Medium Industrial Units  
Industrial units with associated yard-space and ancillary office space.
- 3 Small Industrial Units  
Small industrial units services from shared yards suitable for up to 7.5 tonne vehicles

- 4 Workshop/Atelier  
Ground floor B1c Industrial space serviced from yard. Upper stories provide office space serving small industrial units.
- 5 Parking  
Customer and employee car parking located beneath ramp to north of site, with direct access to office space.

# 4 Typologies

## 4.2 Case Studies

### 4.2.8 Bashley Road (Option A)

#### 4.2.8.1 Site Selection

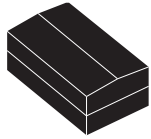

New Build on vacant land

Address Bashley Road, Volt Ave.  
 Postcode -  
 PTAL 1b

Boundary Site  
 Business Inco Europe  
 Site Type Large utilities site /  
 bespoke premises  
 Vacant land

Building Type Large Industrial  
 Site Area 38,089 m<sup>2</sup>  
 Footprint 7,699 m<sup>2</sup>

#### Development Summary

Total Development Value (GDV)	£ 116.4m
Total Development Cost	£ 92.2m
Residual Land Value (RLV)	£ 44.0m
Estimated Land Cost (EUV)	£ 18.9m
Viable	Yes

#### Site History

Owned by Inco Europe, the land is adjoining the Vale Acton - Precious Metal Refinery.

#### Site Selection

Given its current vacancy, the northern and eastern portion of the site are identified and highlighted by most indicators, as suitable for intensification, as it shows a low FAR, low area or volume efficiencies. This condition makes it appropriate for new built intensive developments.

The part of the site that is currently utilised is coming to the end of its operational life and therefore presents an opportunity for comprehensive redevelopment.

#### Development Objectives

Its current accessibility conditions makes the location suitable for large and medium sized warehouses.

Development of HS2 construction sites in Channel Gate as Industrial Innovation District and improved links to Old Oak could bring a demand for increased employment densities in the future.

The scale and proportion of the site provides a unique opportunity in Park Royal for large-scale industrial typologies.

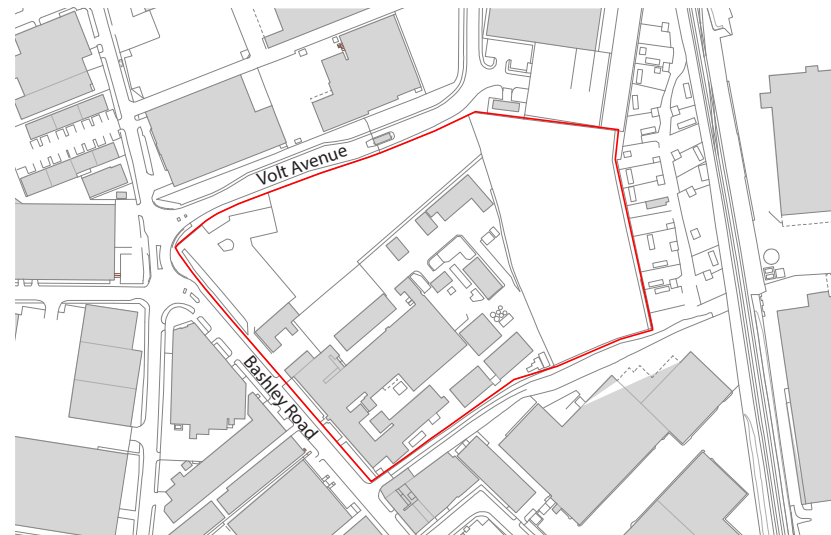
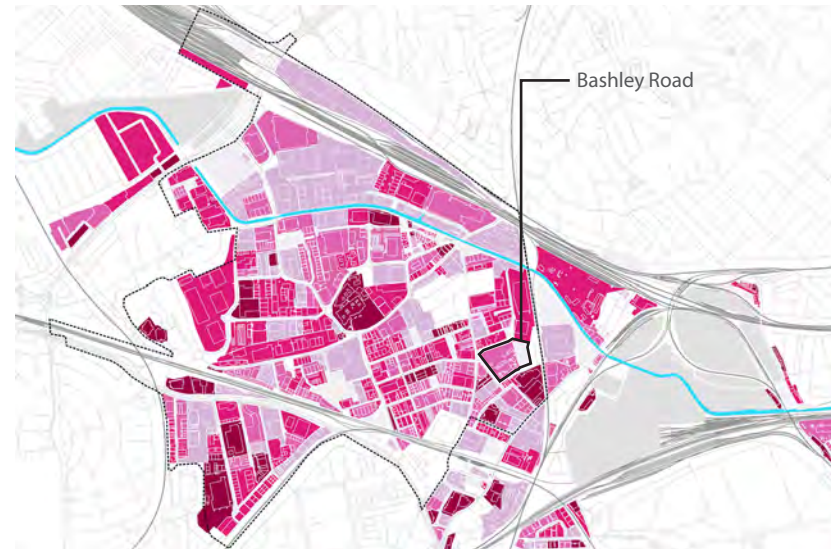

# 4 Typologies

## 4.2 Case Studies

### 4.2.8 Bashley Road (Options A and B)

#### 4.2.8.2 Mix and Space Requirements

Design Principle 1:  
Stack Uses

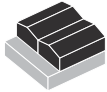

Design Principle 2:  
Share Facilities

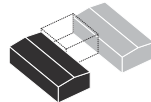

Use Class	Justification
B1a	Provision of office space as ancillary to the built warehouse area
B2/B8	Location also suitable for medium and large scale warehousing

Typology	Justification
Small Office	Provision within industrial units, serving the needs of on site businesses.
Medium Industrial	Size and proportion of site could allocate medium sized warehouse units with enough yard space for medium sized transport vehicles.
Large Industrial	Size and proportion of site could allocate large sized warehouse units with associated yard space.

Typology Requirements  
For spatial/operational requirements for each typology, please refer to appendix E.

	Key Design Considerations
Place making	Site should respect the adjacency to traveller site to the east and proposed conservation area to the south. Office uses should be positioned close to site access.
Viability	Due to its location B1a office uses will be challenging on this site beyond ancillary office space within industrial. Multi-level industrial typologies are feasible due to the good size of this site.
Employment Density	As B1 uses are inappropriate in this location in large quantities, the approach should create an intense provision of industrial space, and hence multi-storey typologies should be considered to increase employment density.

# 4 Typologies

## 4.2 Case Studies

### 4.2.8 Bashley Road (Option A)

#### 4.2.8.3 Schematic Design

**Summary**  
 The design delivers a large industrial spaces suitable for logistics and medium industrial typologies through provision of a ramp for service vehicles.

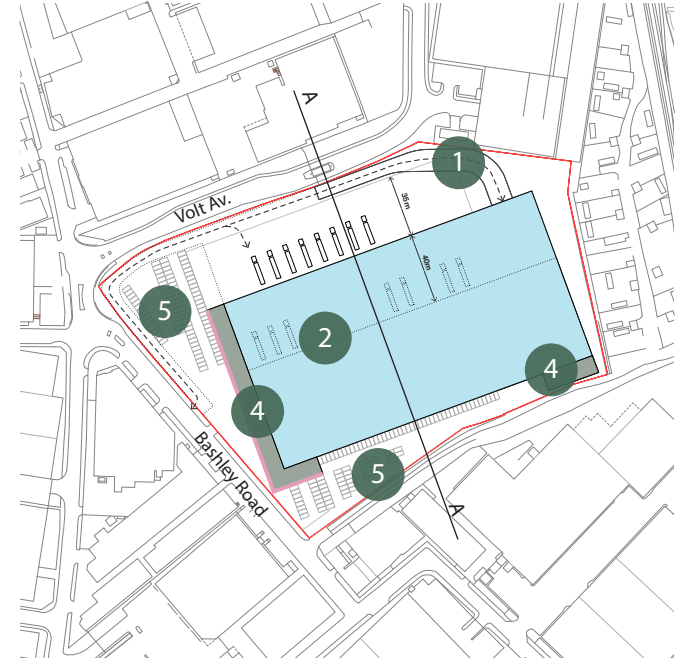
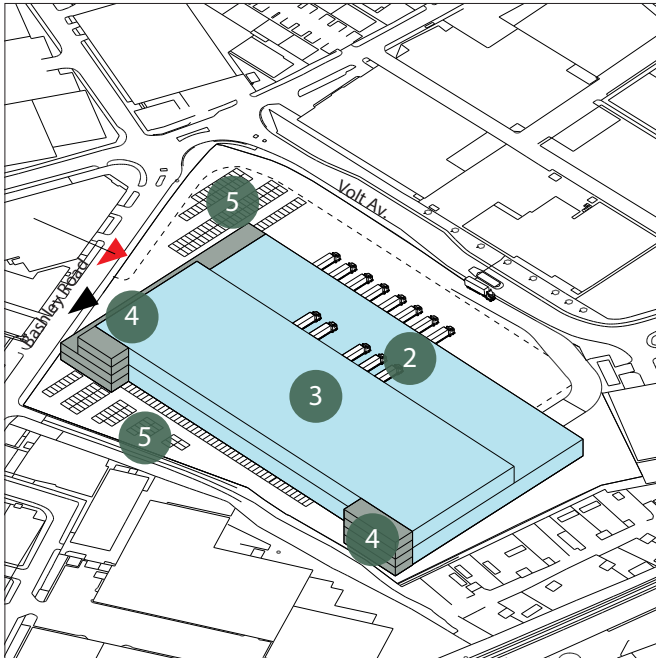
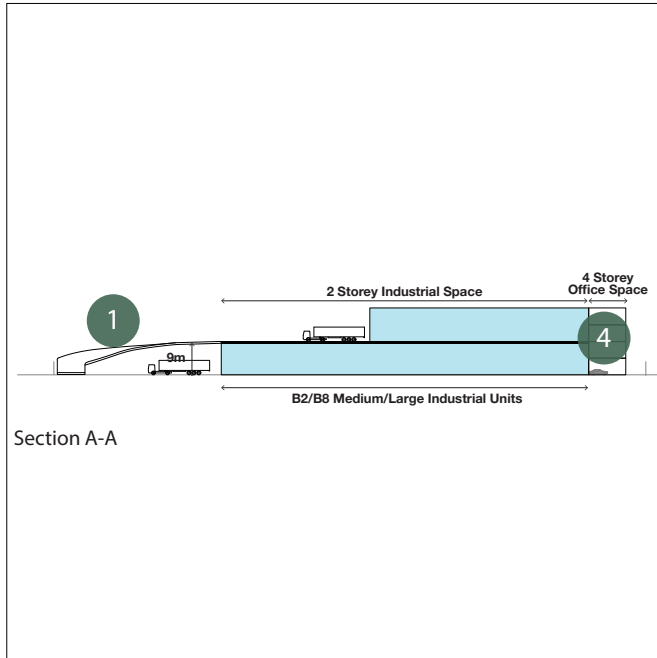

**Approximate Existing Accommodation**

B2/B8	7,699 m <sup>2</sup>	82,870 ft <sup>2</sup>
-------	----------------------	------------------------

**Proposed Quantum of Development**

B1a	4,162 m <sup>2</sup>	44,533 ft <sup>2</sup>
B2/B8	29,284 m <sup>2</sup>	313,338 ft <sup>2</sup>

- 1 Ramp**  
Ramp provides access to industrial units at first floor for 16.5m articulated lorries.
- 2 Large Industrial Units**  
Industrial units with associated yard-space and ancillary office space.
- 3 Medium Industrial Units**  
Medium industrial units services from shared yards suitable for 16.5m articulated lorries.

- 4 Office Space**  
Ancillary office space to industrial units provide direct access from Bashley Road
- 5 Parking**  
Customer and employee car parking located to south and west of site to provide access to office space.

# 4 Typologies

## 4.2 Case Studies

### 4.2.8 Bashley Road (Option B)

#### 4.2.8.4 Site Selection

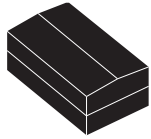

New Build on vacant land

Address Bashley Road, Volt Ave.  
 Postcode -  
 PTAL 1b

Boundary Site  
 Business Inco Europe  
 Site Type Large utilities site /  
 bespoke premises  
 Vacant land

Building Type Large Industrial  
 Site Area 38,089 m<sup>2</sup>  
 Footprint 7,699 m<sup>2</sup>

#### Development Summary

Total Development Value (GDV)	£ 141.5m
Total Development Cost	£ 112.0m
Residual Land Value (RLV)	£ 51.7m
Estimated Land Cost (EUV)	£ 18.9m
Viable	Yes

#### Site History

Owned by Inco Europe, the land is adjoining the Vale Acton - Precious Metal Refinery.

#### Site Selection

Given its current vacancy, the northern and eastern portion of the site are identified and highlighted by most indicators, as suitable for intensification, as it shows a low FAR, low area or volume efficiencies. This condition makes it appropriate for new built intensive developments.

The part of the site that is currently utilised is coming to the end of its operational life and therefore presents an opportunity for comprehensive redevelopment.

#### Development Objectives

Its current accessibility conditions makes the location suitable for large and medium sized warehouses.

Development of HS2 construction sites in Channel Gate as Industrial Innovation District and improved links to Old Oak could bring a demand for increased employment densities in the future.

The scale and proportion of the site provides a unique opportunity in Park Royal for large-scale industrial typologies.

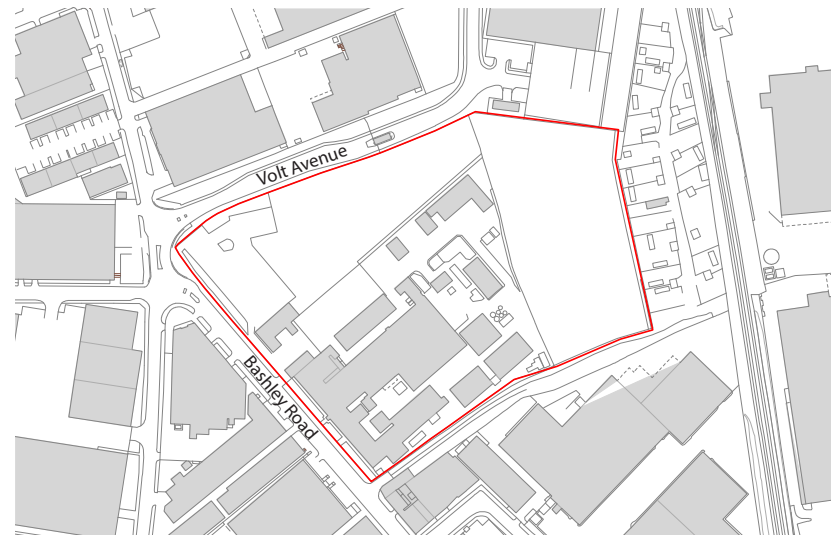
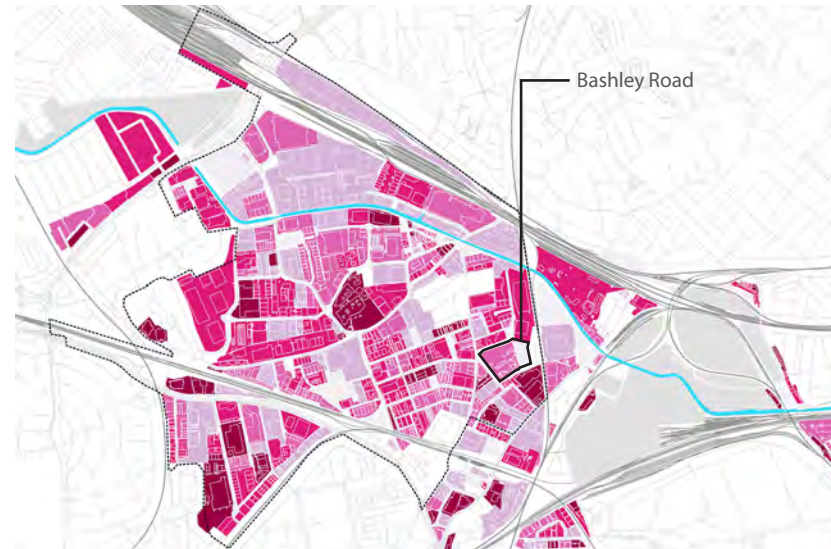

# 4 Typologies

## 4.2 Case Studies

### 4.2.8 Bashley Road (Option B)

#### 4.2.8.5 Schematic Design

**Summary**  
 The design delivers a large industrial spaces suitable for logistics and medium industrial typologies on upper floors through provision of a ramp for service vehicles.

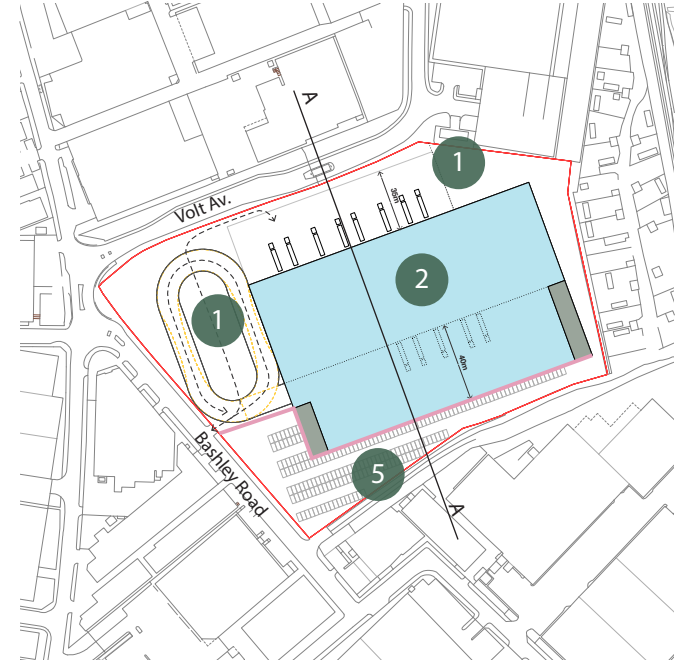
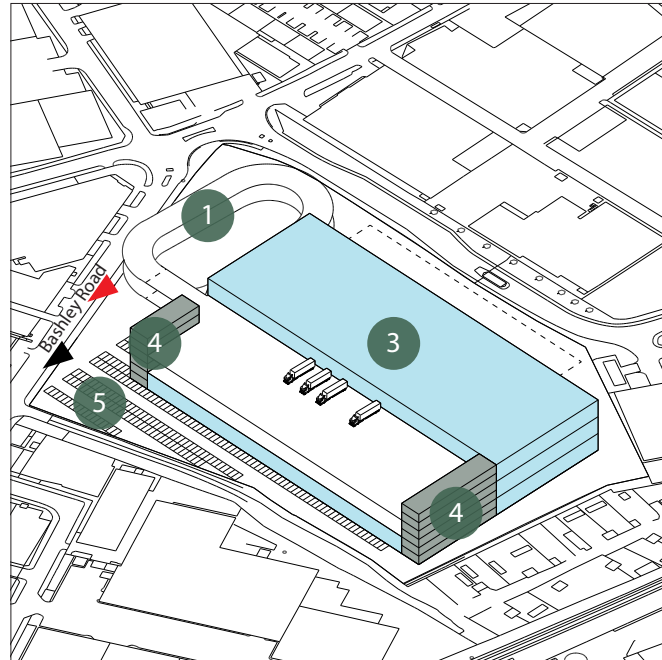
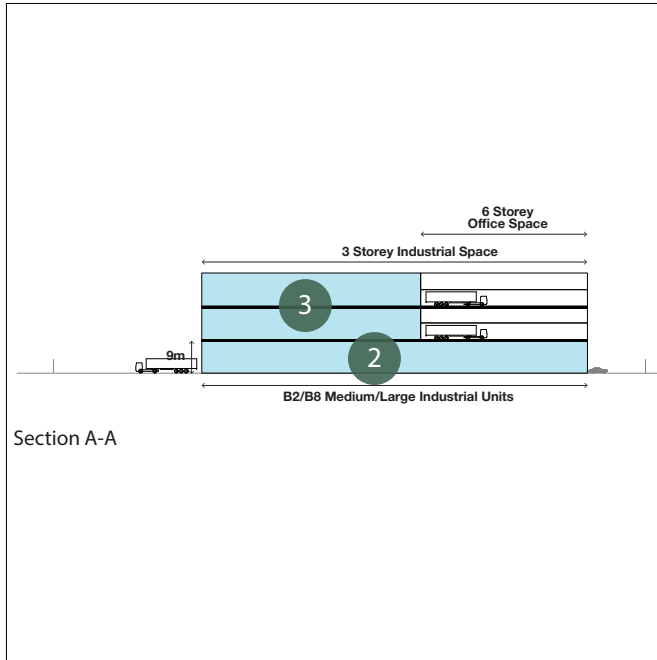
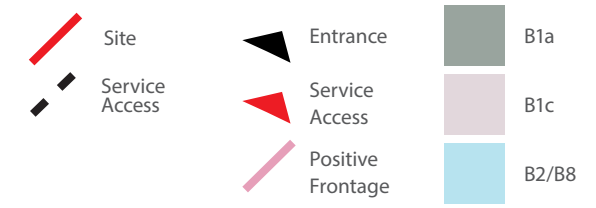

**Approximate Existing Accommodation**

B2/B8	7,699 m <sup>2</sup>	82,870 ft <sup>2</sup>
<b>Proposed Quantum of Development</b>		
B1a	4,500 m <sup>2</sup>	48,150 ft <sup>2</sup>
B2/B8	36,162 m <sup>2</sup>	386,933 ft <sup>2</sup>

- 1 Ramp**  
Ramp provides access to industrial units at first floor and second floor for 16.5m articulated lorries.
- 2 Large Industrial Units**  
Large Industrial units at ground floor with associated yard-space and ancillary office space.
- 3 Medium Industrial Units**  
Medium industrial units on first and second floors serviced from shared yards suitable for 16.5m articulated lorries.

- 4 Office Space**  
Ancillary office space to industrial units provide direct access from Bashley Road
- 5 Parking**  
Customer and employee car parking located to south of site to provide access to office space.

## 4 Typologies

### 4.2 Case Studies

#### 4.2.8 Bashley Road (Options A and B)

##### 4.2.8.7 Precedents



Single Ramp (GLP Misato III, Misato City)

Multi-storey logistics facility access via a single ramp for ingress and egress allows for a more compact site planning.



Cladding (P+R Car Park, Zutphen)

Due to the prominence of the ramp particular attention should be paid to its elevation.



Multi-storey warehousing (X2, Heathrow)

Vehicles access service yards on upper storeys via vehicle ramp

## 4 Case Studies

### 4.3 Stakeholder Consultation Summary

#### 4.3.1 Methodology

To gauge attitudes to the emerging design approaches, a range of key stakeholders attended a consultation session to offer comments.

##### Structure

The session was split into two sections, one introducing the approach taken to identifying case study sites and the broader intensification strategy, and a second section where comments on specific design approaches were encouraged.

The introductory section covered the following elements from the study:

- Purpose of the study
- Summary of market analysis
- Introducing intensification types
- Methodology for identifying sites
- Viability methodology
- Key viability findings
- Key opportunities and constraints

The second part of the consultation focussed on 4 case studies, covering the variety of approaches to intensification taken in the project. These covered:

- Willen Field Road
- Gorst Road
- Minerva Road
- North Acton Road

Discussion on the case studies was focussed around asking specific questions on each case study, covering demand, design and management:

- Would this type of accommodation meet the current needs of your business/you customers?
- How could these designs be improved?
- Some of these typologies could be configured as managed workspaces-divided into smaller units with some shared space. What approaches could there be to managing these spaces?

##### Attendees

###### Business Profiles

Attendees from business included people managing multiple properties, operators of individual companies, representatives and consultants:

- Architect
- Food and beverage business manufacturing consultancy
- Artist studio manager
- Business representative

##### Developer Profiles

Representatives from development attended from two key stakeholders in Park Royal from:

- Segro
- Dephna

##### Authority Profiles

Local Authorities with land that constitutes part of Park Royal were in attendance:

- Ealing council



# 4 Case Studies

## 4.3 Stakeholder Consultation Summary

### 4.3.2 Outcomes

#### Demand

Comments on issues around demand generally covered two topics- how to ensure intensification caters for existing businesses and how suitable the spaces proposed in the case studies are for the consultees.

#### Existing Businesses

- Small (approx 10,000 sq-ft) units are in demand from businesses already within Park Royal. The demand for larger sites tends to come from businesses outside of Park Royal that are looking to relocate.
- Spaces should cater for businesses looking to move on and scale up into larger premises
- Higher rents could be achieved if intensification included A1 uses
- Standalone office space in locations far away from transport nodes is difficult to let.
- Office space should be introduced in a way that doesn't harm Park Royal's 'brand'
- Larger sites are rare

#### Space

- Large goods in requiring 40ft lorries can be shared as deliveries are infrequent.
- Shared yards are most suitable is used by compatible businesses.
- Spaces should be possible to subdivide

internally, providing flexible spaces for small businesses.

- Multi-storey typologies are feasible and would be marketable.
- Proposals should include B1a, B1b and B1c.
- Space would still let if yard space only accommodates smaller delivery vehicles.
- HS2 sites could be used for decant whilst new development takes place.
- Questions were raised over how high rents could be achieved on the floors above 3 storeys.

#### Design

Consultees reactions to the designs largely focussed around how intensification can create a better urban environment, the implications of higher density on the transport infrastructure and operational issues.

#### Urban Environment

- Where possible, intensification sites should respond to and improve access to green spaces
- Intensification sites in Old Park Royal need improved pedestrian routes to underground, overground and mainline stations.
- Improved amenity required to attract occupiers into Old Park Royal
- Exploiting the canal received both

positive and negative responses. Whilst some appreciated the use of the canal to improve worker welfare, others questioned whether industrial space would benefit from views over the canal and raised issues around the conflict between cyclists and pedestrians along the canal path.

#### Transport

- The intensification of sites proposed needs to be aligned to a wider transport strategy for vehicle routes in Park Royal.
- Some case study sites such as those located in Old Park Royal are currently particularly congested.
- The potential to build over yards was proposed, and the consultees considered that the structural grid over the yard this would involve would not inhibit operation.

#### Operation

- Shared yards were considered to be areas where efficiencies and intensification could be achieved.
- Smaller businesses require access for large HGVs on a weekly or fortnightly basis, and sharing access for a loading bay suitable for this type of delivery would mitigate a significant amount of congestion.
- Managing the different cycles throughout the working day used by

different sectors could also intensify the activity in Park Royal without causing further congestion.

- Sharing of facilities is likely to have most potential between complementary businesses, and in some sectors there are already examples of this in Park Royal.
- The risks of shared facilities such as good lifts were highlighted, such as what happen if the lift breaks down.

#### Management

Whilst it was noted that there are some examples of multi-let developments already operating in Park Royal, consultees commented that this would need to expand in order to achieve the intensification set out in this project.

- It would be important to attract developers who are good at site management, potentially beyond those currently operating in Park Royal currently.
- Systems for sharing facilities will require co-ordination.
- More intensive management of sites to maximise the activity they can support could also happen in refurbished buildings.
- The question was raised whether CPO powers would be needed to achieve the level of additional jobs set out in this study.

# 4 Case Studies

## 4.4 Viability Methodology

### Approach to Assessing Viability

The viability of each of the Park Royal proposals have been assessed through the following approach:

1. Identify future growth sectors for Park Royal – utilising findings from the Future Employment Growth Sectors Study.
2. Identify the applicable development uses by planning use class – based on evidence from Future Employment Growth Sectors Study. This informed the collation of the types of property market evidence needed.
3. Collation of property market evidence from primary market information sources – research and collate property market evidence from databases such as CoStar as well as refined through discussions with agents from Cushman and Wakefield. Appropriate values and yields have been applied on a site by site basis and in accordance to use, then input into the model.
4. Establishing an Existing Use Value (EUV) benchmark against which viability results can be tested – the EUV of each development site has been estimated

by calculating estimated floor areas and applying applicable rental values and capitalisation rates. The EUV forms the benchmark against which the residual land value of each site's development proposals are measured for viability.

5. Financial modelling to identify the residual land value (RLV) for each of the study development proposals - financial viability appraisals have been undertaken using development appraisal software to identify the RLV. Utilising an established set of development (including value and cost) assumptions and proposals for each site - expressed as uses, floor areas and any associated infrastructure.

The residual sum represents the value of the land under the scheme appraised (while making the assumptions outlined in this report). This sum therefore represents the amount a developer undertaking the proposed scheme could afford to pay for the site (including land assembly cost, relocation of existing occupiers, etc.) at the outset of the development. For a scheme to be viable the RLV has to be greater than the benchmark EUV of the asset in order to provide a financial rationale as to why the sites should be subject to redevelopment.

### Existing Use Values Overview

This section provides an overview of how the Existing Use Values (EUVs) have been established for each of the study sites.

The EUVs are important in establishing a benchmark against which development appraisal results can be tested for viability. In this sense EUVs are known as the benchmark land value (BLV).

All properties within the study area are commercial therefore require a rent a capitalisation approach to ascertain their AUV.

### Existing Use Values (EUV) – The Benchmark

Existing use values have been calculated by:

- Collating comparable evidence of commercial rental values and yields by property quality (low, medium, high), type and size.
- Confirming and adjusting commercial values with Cushman and Wakefield.
- Multiplying estimated existing floor areas by capital values utilising comparable evidence

Tables in appendix F.1 set out the value inputs that have been utilised to calculate the EUV of each study site.

- Expressed as:
  - Square feet (sq ft)
  - Square meters (sq m)
  - Pounds per square feet (£ psf)
  - Pounds per square meter (£ psm)

## 4 Case Studies

### 4.5 Costs and Values Summary

#### Viable Case Studies

Sites which were more viable generally had the following mixture of characteristics:

- Lower existing use values resulting from a mixture of lower density and condition of existing buildings
- Industrial space acts as a value driver – circa 65% was considered a good proportion of industrial space to make scheme viable.
- reduced storeys thereby keeping construction costs lower.
- Reduced internal servicing and infrastructure requirements.

#### Unviable Case Studies

Two case studies were found not to be viable.

#### Alpha Beta

Based on the base cost and value assumptions made, the Alpha Beta case study was unviable. This was due to:

- A higher EUV resulting mostly from the high existing site density.
- The suitability of the site for a high proportion of B1a office space and low proportion of industrial space.

#### Origin Business Park

Based on the base cost and value assumptions made, the Origin Business Park case study was unviable. This was due to:

- A high EUV resulting mostly from the existing building being modern, efficient and well configured space that will achieve good industrial rental values.
- The suitability of the site for a high proportion of B1a office space and low proportion of industrial space.

Through sensitivity testing it was identified that a very small future increase in overall rents could make the site viable.

#### Viability Commentary

Although the case studies included are viable and so offer the potential

Site	Reference	RLV	EUV	Surplus/ Deficit
4-6 Willen Field Road	4.2.1	£4,913,000	£3,382,000	£1,530,000
37 Gorst Road	4.2.2	£3,061,000	£2,335,000	£726,000
13 Waxlow Road	4.2.3	£2,846,000	£1,369,000	£1,477,000
North Acton Road	4.2.4	£5,243,000	£3,039,000	£2,204,000
97 Victoria Road	4.2.5	£5,243,000	£2,993,000	£2,956,000
40 Minerva Road	4.2.6	£7,134,000	£2,940,000	£4,194,000
3 Bashley Road	4.2.7	£13,565,000	£7,205,000	£6,360,000

Table shows best performing and prototypical design options. See appendix C for high capacity unviable design options.

Site	Reference	RLV	EUV	Surplus/ Deficit	Viable?
(7-11) Minerva Road	C.4	£1,355,000	£3,994,000	-£2,639,000	N
(7-11) Minerva Road +25% Rent	C.4	£5,119,000	£3,994,000	£1,125,000	Y
Origin Business Park	C.5	£8,040,000	£8,660,000	-£620,000	N
Origin Business Park +1.25% Rents	C.5	£8,930,000	£8,660,000	£270,000	Y
Origin Business Park +2.5% Rents	C.5	£9,819,000	£8,660,000	£1,159,000	Y

Table shows unviable design options and rent levels at which they reach viability

## 4 Case Studies

### 4.5 Costs and Values Summary

for development or redevelopment there are many reasons why this might not happen in the short term. These include the length of existing occupational leases and fact that the existing building meet the needs of owner occupiers

General observations which could contribute towards some sites being less viable:

Multi storey buildings are more expensive to build new for all uses, in particular where the following are required:

- Lifts
- Vehicle ramps
- Concrete frame buildings

Sites with high existing use values on a per acre basis - for example (7-11) Minerva Road (high existing density) and Origin Business Park (modern, well configured space) – make achieving viability more challenging.

Office rental values achievable are currently at levels which are low relative to the cost of construction. Opportunities

exist to create value where limited office space is provided alongside industrial development, including as part of refurbishment of existing space. We have assumed the refurbishment and conversion costs at 60% of new build space.

## Section C - Conclusions

The employment uplift potential on the case study sites provides the basis to assess additional employment capacity across the study area.

5.1 Methodology for Additional Employment Capacity Calculation

5.2 Locations and Additional Employment Capacity

# 5 Jobs

## 5.1 Methodology for Additional Employment Capacity Calculation

### 5.1.1 Workflow

In order to arrive at a robust figure for the additional employment capacity across the study area the following methodology establishes:

- The quantum of employment space potentially created through the intensification
- The potential employment density of this new employment space
- The deliverability of achieving this quantum of space

The additional employment capacity is arrived at through the following steps:

1. Select sites suitable for intensification using indicators described in section 3.3.
2. From these sites, select prototypical sites that are most viable/deliverable
3. Through design testing of case studies, calculate quantum of space by use class possible on this site as a ratio of the site area.
4. Establish site profile based the site type, existing building type and condition, ownership (described on page 42).
5. Use this profile to locate intensification sites across the study area (described on page 44).
6. Potential employment densities on these sites will be assessed by use class, reflecting the likely occupiers based on the space requirements and geographical preferences set out in the Future Employment Growth Sectors Study (describes on page 28).

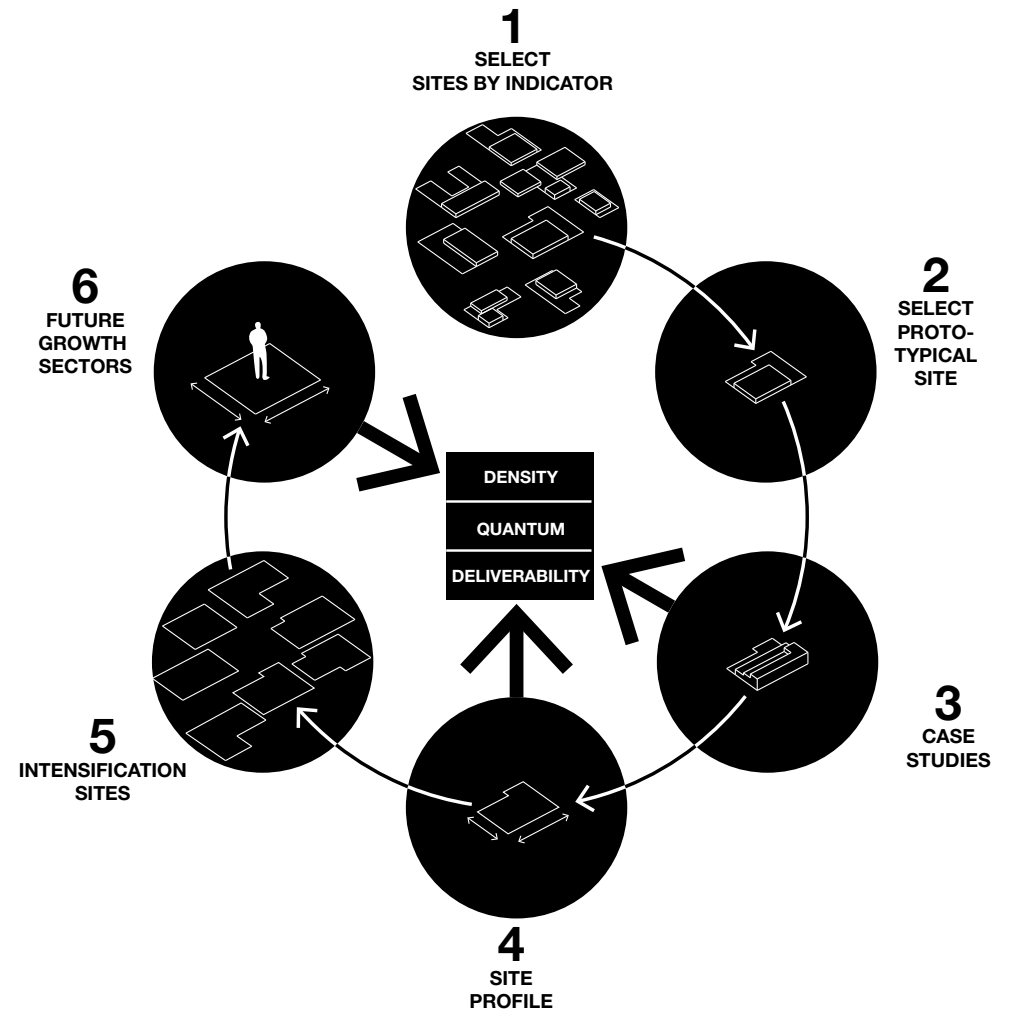

## 5 Jobs

### 5.1 Methodology for Additional Employment Capacity Calculation

#### 5.1.2 Intensification Sites

##### Site Profile

For each case study there are certain spatial indicators (type of site) and incentives (reasons to redevelop) that provide a site profile (see Appendix C.7). These key characteristics determine:

- what type of design approach can be accommodated on a site
- whether they are likely to be redeveloped

These characteristics have been used to look for comparable sites that could accommodate similar levels of intensification, and can be used to calculate a site wide figure for additional employment capacity across Park Royal as a whole.

Intensification sites identified using each case study site profile match all the spatial indicators of the case study site, therefore ensuring that the key elements of how the site is planned- access for goods, vehicles and people, separation of uses, appropriate yard dimensions etc. can be accommodated.

Intensification sites must match one of the incentives, providing a reason why landowner might develop in the near future, such as poor site coverage, many buildings within ownership etc.

##### Spatial Indicators

##### Description

---

##### Site Area

The area of the site determines the spatial typologies and mix of uses that can be accommodated. The area should allow adequate yard space, dedicated entrances to different uses and providing space of suitable proportions for market demand.

---

##### Site Proportion

Appropriate site proportions (calculated as how far the shape of the site deviates from a perfect square) ensures that the access and building typologies developed in the case studies are applicable to the intensification sites.

---

##### Average Building Height

Average height identifies buildings that have sufficient height to accommodate mezzanine floors and internal subdivision. It can also be used to locate buildings that are currently low and can accommodate additional storeys.

---

##### Building Footprint

Building footprint identifies buildings that have sufficient internal area to accommodate internal sub-division into smaller units.

---

##### Incentives

---

##### Area Efficiency

Area efficiency identifies sites that could accommodate significant increases in employment space, and therefore likely to be more attractive to redevelop.

---

##### Buildings per Freehold

Freeholds containing multiple buildings present an opportunity to decant existing businesses during phased redevelopment. This makes redevelopment more attractive to landowners, particularly owner-occupiers.

## 5 Jobs

### 5.1 Methodology for Additional Employment Capacity Calculation

#### 5.1.2 Intensification Sites

##### Site Capacity

A lower, conservative estimate for additional employment capacity reflects only the area generated by intensification sites located using case studies that are viable under current market conditions.

A higher, more ambitious additional employment capacity takes into account the intensification sites that would result from all feasible design approaches which could be viable in the future (see appendix C for unviable case studies).

Sites used for low estimate (all viable)	Reference Case Study	Sites used for high estimate (max. capacity)	Reference Case Study
Willen Field Road	4.2.1	Willen Field Road	4.2.1
Gorst Road	4.2.2	Gorst Road	C.1
Waxlow Road	4.2.3	Waxlow Road	C.2
North Acton Road	4.2.4	North Acton Road	C.3
Victoria Road	4.2.5	Victoria Road	4.2.5
Minerva Road	4.2.6	Minerva Road	4.2.6
Bashley Road	4.2.7	(7-11) Minerva Road	C.4
		Bashley Road	4.2.7
		Origin Business Park	C.5

# 5 Jobs

## 5.1 Methodology for Additional Employment Capacity Calculation

### 5.1.3 Employment Capacity Assessment

#### Methodology

The employment capacity assessment has been undertaken via a two-stage process:

1. Cross referencing the Park Royal intensification locations against the findings of the OPDC Future Growth Sectors Study, to identify the types of employment activities which might be expected to locate in different areas of Park Royal.
2. Applying standard government economic appraisal methodologies to assess the gross and additional employment which could be accommodated within the Park Royal via the delivery of the identified opportunities for intensification.

#### Employment Numbers

The employment numbers have been arrived at by the following steps:

1. Matching of uses and activities  
As a first step, the OPDC Future Growth Sectors research has been used to provide an assessment of the types of sectors and activities likely to locate in different parts of Park Royal. This includes: the likely balance of activity between B2 and B8 uses across the area, and different types of spaces which might be accommodated within each of the broad use classes (e.g., B1a –

professional service office space versus managed workspace; B2 – general manufacturing space versus maker space; B8- national, regional and final mile distribution activities).

2. Selection of appropriate employment densities  
The 2015 HCA Employment Densities Guide provides a set of benchmark employment densities for different use classes and is the approved methodology for economic appraisal of this nature. The guidance has been used to select an appropriate employment density for each of the uses and activity identified in step 1.
3. Adjustment of floorspace figures  
Where necessary, Gross Internal Area (GIA) floorspace figures have been adjusted to align with HCA employment density benchmarks. For B1a and B1c uses, GIA has been converted to Net Internal Area (NIA); for B8 uses, GIA has been converted to Gross External Area (GEA). No conversion is necessary for B2 space. In line with standard practice, conversion figures of 0.9 and 0.8 have been used to move from GEA to GIA, and GIA to NIA respectively.

4. Assessment of gross employment capacity  
Building on the outcomes of steps 1 to 3, the gross employment capacity of the sites has been estimated by applying the allotted employment densities to the floorspace figures for each use class within the various intensification locations.
5. Assessment of additional employment capacity  
Employment currently accommodated on the intensification sites has been assessed using the employment density by employment site as set out in the Industrial Land Review (2016) based on site observations and information obtained from businesses. These estimates of current employment have then been subtracted from the estimates of intensified employment capacity, to arrive at the figure for additional employment capacity.

All figures are for full time equivalent (FTE) employment and are intended for indicative purposes only. The numbers provide an estimate of the theoretical employment capacity of the sites once intensified; they do not make any adjustments to take into account future occupancy / vacancy levels, the potential for displacement of jobs from elsewhere in the area, or the potential for natural growth / change which might occur anyway even in the absence of intensification (dead-weight).

# 5 Jobs

## 5.2 Locations and Additional Employment Capacity

### 5.2.1 Intensification Sites

#### Intensification Site Locations

Suitable intensification sites have a broad spread across Park Royal, reflecting the spatial diversity of the case study sites.

Multiple sites in close proximity are identified along Abbey Road, Willen Field Road, Standard Road, Minerva Road and Chase Road.

- Willen Field Road
- Gorst Road
- Waxlow Road
- North Acton Road
- Victoria Road
- (40-54A) Minerva Road
- (7-11) Minerva Road
- Bashley Road
- ..... Study area boundary

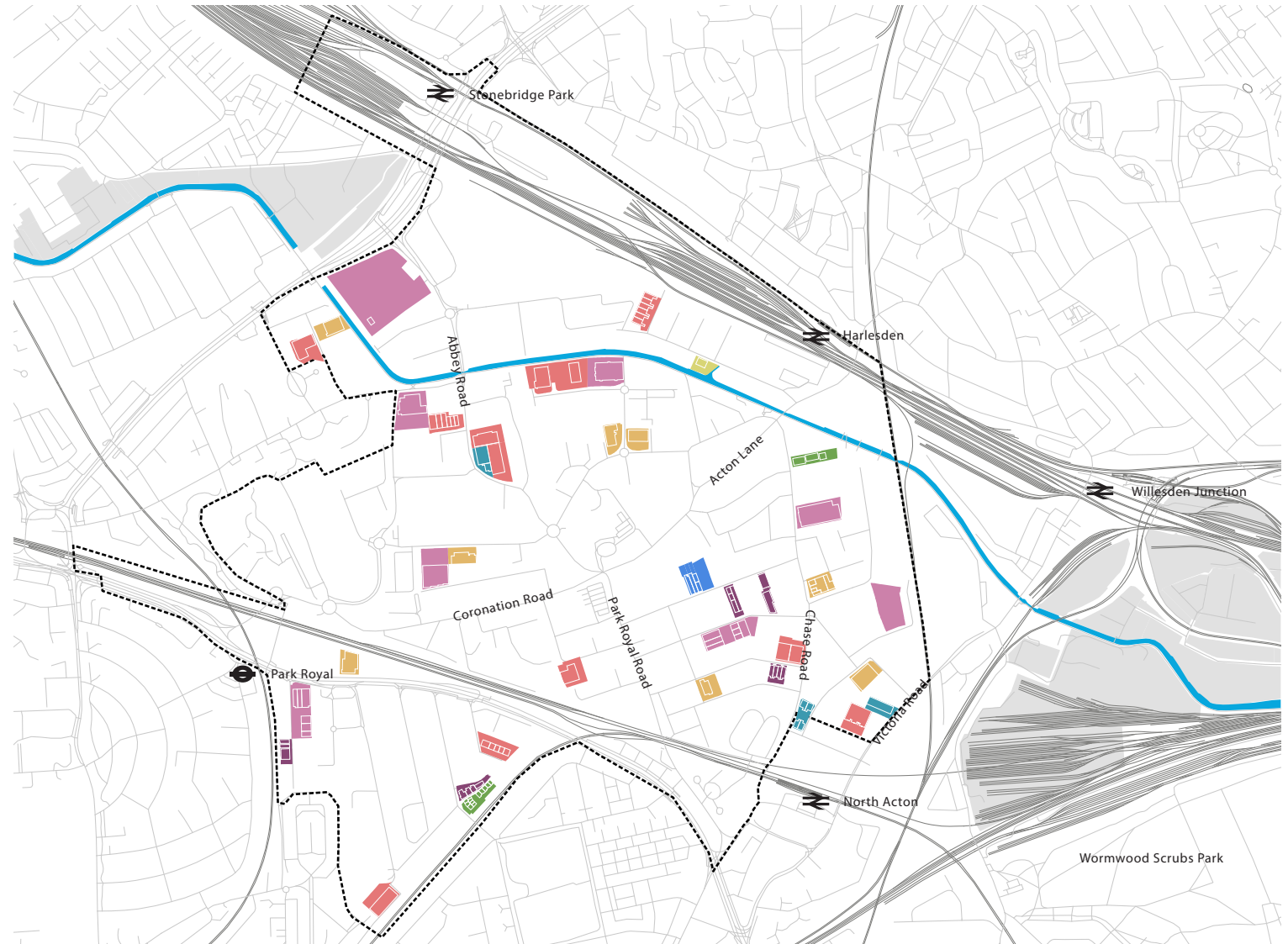

# 5 Jobs

## 5.2 Locations and Additional Employment Capacity

### 5.2.2 Potential Floorspace

#### Floorspace by Intensification Type

The table opposite summarises the total floorspace of intensified sites set out on the map on page 107.

Site Type	Reference Case Study	Total Floorspace GIA Low Estimate	Total Floorspace GIA High Estimate	Maximum Number of Intensification Sites
A	Willen Field Road	93,000 m <sup>2</sup>	93,000 m <sup>2</sup>	12
B	Gorst Road	41,900 m <sup>2</sup>	43,300 m <sup>2</sup>	8
C	Waxlow Road	3,500 m <sup>2</sup>	3,500 m <sup>2</sup>	1
D	North Acton Road	16,600 m <sup>2</sup>	16,200 m <sup>2</sup>	2
E	97 Victoria Road	26,700 m <sup>2</sup>	26,700 m <sup>2</sup>	3
F	40-54A Minerva Road	13,700 m <sup>2</sup>	13,700 m <sup>2</sup>	1
G	(7-11) Minerva Road	0 m <sup>2</sup>	28,800 m <sup>2</sup>	5
H	Bashley Road	113,700 m <sup>2</sup>	113,700 m <sup>2</sup>	8
I	Origin Business Park	0 m <sup>2</sup>	24,300 m <sup>2</sup>	5

## 5 Jobs

### 5.2 Locations and Additional Employment Capacity

#### 5.2.3 Potential Job Capacity

##### Job Capacity by Intensification Type

Larger sites such as Willen Field Road, Gorst Road and Bashley Road generate a significant part of the overall Additional Job Capacity in Park Royal.

This is because their size and proportion is typical to the grain of Park Royal, and the size of site allows a compact mix of both industrial and office uses on a single site.

##### Job Capacity per Site

Although they are less prototypical as site types and hence create a lower overall uplift in jobs than the larger sites listed above, North Acton Road, Victoria Road and Alpha Beta give the highest employment capacity per intensification site on average.

This is a result of the higher proportion of B1 uses over a multi-storey building, which creates a very high density of employment within a single site.

Site Type	Reference Case Study	Additional Employment Capacity Low Estimate	Additional Employment Capacity High Estimate	Maximum Number of Intensification Sites
A	Willen Field Road	2,050	2,050	12
B	Gorst Road	450	1,150	8
C	Waxlow Road	100	100	1
D	North Acton Road	450	450	2
E	97 Victoria Road	650	650	3
F	40-54A Minerva Road	400	400	1
G	(7-11) Minerva Road	0	1,400	5
H	Bashley Road	1,000	1,000	8
I	Origin Business Park	0	700	5

# 5 Jobs

## 5.2 Locations and Additional Employment Capacity

### 5.2.4 Potential Job Capacity by Place

#### Additional Employment Capacity

The table below summarises the additional employment capacity of each place in Park Royal.

Place	Additional Employment Capacity Low Estimate	Additional Employment Capacity High Estimate
Park Royal	3,750 jobs	5,550 jobs
Old Park Royal	1,350 jobs	2,350 jobs
<b>Total</b>	<b>5,100 jobs</b>	<b>7,900 jobs</b>

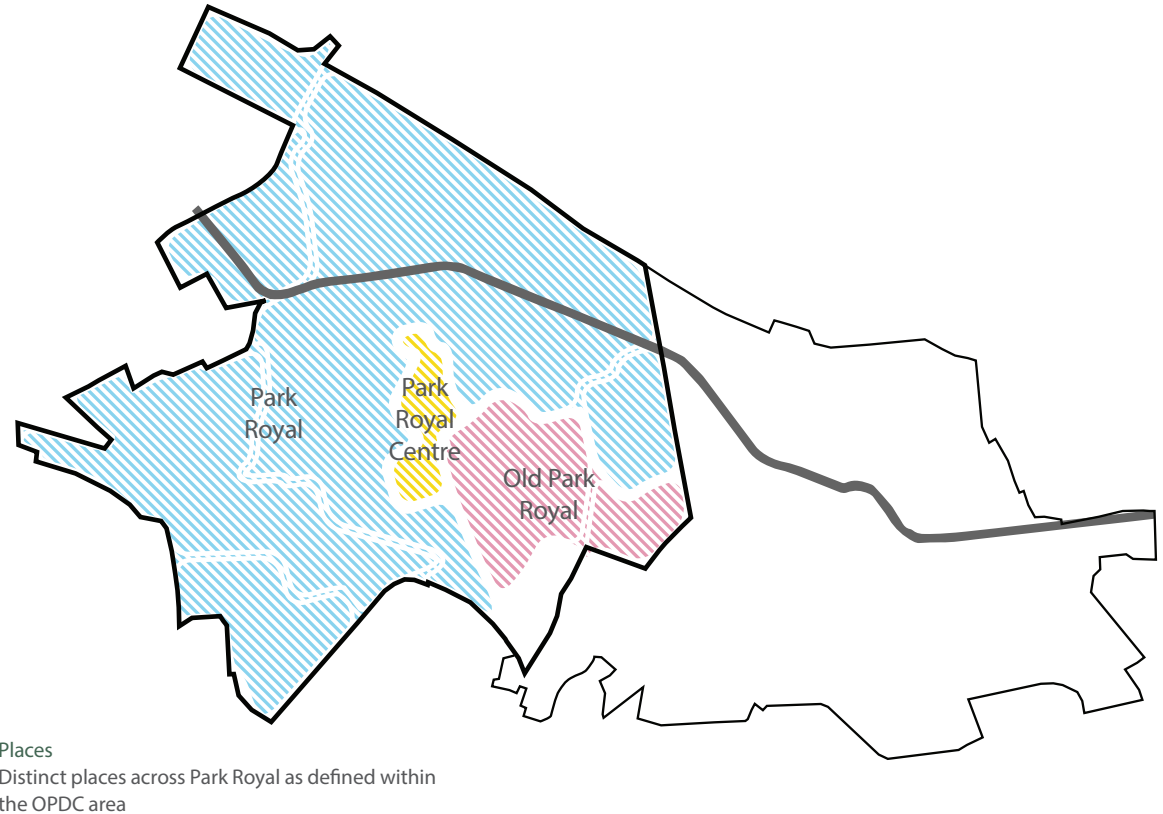

The intensification study highlights where intensification would be most effective.

6.1 Areas of Focus

6.2 Recommended Next Steps

# 6 Delivery

## 6.1 Areas of Focus

### Target Typologies

The majority of typologies developed proved to be viable. Development of this type is currently not happening in Park Royal and the stakeholder consultation did suggest some areas which need consideration, such as the need for decant space and rarity of larger sites for development, management risks.:

The most viable intensification strategies under current market conditions are

- New provision on vacant land
- Partial refurbishment and infill
- Comprehensive redevelopment

Focussing on how sites can become available for comprehensive redevelopment, such as phased development, decant of existing businesses and facilitating land assembly would be key in encouraging intensification across Park Royal.

The typologies that deliver the largest increase in additional employment capacity are those developed through Willen Field Road, Gorst Road and Bashley Road case studies.

This suggests that a focus of industrial intensification strategies should be on multi-storey industrial typologies that allow

access for smaller delivery vehicles to first floor level.

These typologies that are both viable and offer the most potential for additional employment in Park Royal demonstrates that the inclusion of a high quantum of industrial space within new developments is a key value driver where new or refurbished B1a office space (less viable) is also sought.

### Target Growth Areas

Clustering of intensification sites along Abbey Road, Willen Field Road, Standard Road, Minerva Road and Chase Road present an opportunity for strategic planning that mitigates the potential congestion associated with higher employment densities and creates business ecologies that are more than the sum of their parts.

The pedestrian route along Chase Road between these clusters at Standard Road and Minerva Road and public transport connections at North Acton are of strategic importance in un-locking these sites for intensification.

### Short Term Opportunities

The strong commercial viability of the larger typologies developed through the Willen Field Road and Bashley Road case studies suggests that these should

prioritised, as they have the potential to both attract investment and provide an exemplar project in the area.

# 6 Delivery

## 6.2 Recommended Next Steps

The development of intensification strategies for Park Royal highlights where further work could provide significant steps towards the delivery an intensive industrial area.

### Set the Standard

#### Design Guidance

The findings of this report can be used to promote ambitious proposals through the planning process.

Officers could encourage ambitious proposals through the development of a Park Royal Design Guide covering the operational, structural and technical parameters associated with the intensification strategies developed in this study.

### Exemplar Development

Intensification in Park Royal could be greatly encouraged through development of an exemplar project, acting as a proof of concept and setting a standard for industrial development.

Acting as a development partner or otherwise, OPDC and other private land owners could utilise land outside of study area to catalyse intensification.

Alternatively, where key sites are under-occupied or have been out of use for some years, OPDC may consider whether

there is a strategic case and role for acquiring, using compulsory powers where necessary. OPDC would therefore then take a more direct role in how sites are delivered whether through themselves or with a development partner.

This exemplar development should focus on smaller multi-let typologies that are unlikely to be developed at scale by stakeholders currently active in Park Royal.

Aiming this development at accommodating sectors identified in the Future Growth Sectors study but not currently present in large numbers in Park Royal has the potential to catalyse clustering.

The study shows the potential of larger sites such as Willen Field Road and Bashley Road to delivery significant uplift in employment densities through multi-storey industrial development. Due to their typical site characteristics an exemplar development of this type has the potential to trigger a step change in the typological approaches adopted across Park Royal.

Further engagement with developers who have the capacity to deliver these typologies should be undertaken.

### Shared Facilities

A key incentive to intensification is shared facilities, creating a clustering dynamic and creating a more efficient use of space and therefore creating employment space.

Significant improvements could be achieved through co-ordinating initiatives between businesses.

The formation of a Business Support Programme could provide advice and funding for businesses to efficiently use space and facilities, such as shared yards, deliveries and meeting rooms.

### Address Impact

#### Planning Policy

OPDC should ensure planning policy continues to protect and safeguard space for industrial uses. This could consider some flexibility to encourage high employment density uses such as office yet recognise that B2/B8 industrial space is the key value driver and therefore the critical element of any scheme.

It should also ensure that industrial uses have sufficient yard space, loading bays and parking to meet occupier operational needs and avoid contributing to highways issues.

Planning mechanisms should be explored to strategically control the location and

quantum of B1a in order to protect Park Royal's SIL areas.

### Transport

The commercial viability of a greater mix of employment uses in Park Royal would be enhanced through improving transport in the area. The targets of this approach should be improved public transport accessibility, thereby allowing a greater number of employees to reach their place of work without increasing car usage, and a strategic approach to servicing industrial areas.

Stakeholder consultations highlighted that existing business owners and developers in Park Royal are concerned at the potential stress further employment growth of the magnitude suggested in this study could put on an already congested infrastructure.

However, the consultations highlighted that the business community are open to new approaches to this challenge, and have ideas for how shared loading facilities could alleviate the stress on roads.

Further consultation on this issue with the business community focussing on a pilot area of Park Royal would be an important step in delivering intensification.

A cluster of potential intensification sites

# 6 Delivery

## 6.2 Recommended Next Steps

around Standard Road, Minerva Road and Chase Road has been identified in this study and would be a suitable location for the pilot project.

The pilot area could explore technology enabled solutions to the live management of car parking, yards, servicing to mitigate the potential pitfalls of businesses working in closer proximity and with higher employment densities.

Alternative approaches to staff and customer parking and space allocated for deliveries can be trialled in consultation with businesses to improve the street efficiency and urban environment.

### Employee Welfare

Addressing the services and facilities available to employees in Park Royal would be key to attracting new businesses. Better worker welfare through improved social infrastructure such as childcare facilities and improved amenity should be reflected in planning policy.

The 24hr cycle of an industrial area brings the opportunity to intensify activity. Improved access and pedestrian experience at night will attract businesses who are looking to locate in a suitable location to enable shift work.

### Maximise Value

Updates to the Infrastructure Delivery Plan should be developed to provide a site-wide strategy to locate key projects such as transport and employee welfare initiatives outlined above, parks, canal and key routes to tube stations that would ensure value in new development is maximised.

This would optimise opportunities arising from the future redevelopment of Old Oak Common in terms of transport connectivity and environmental improvements to attract occupiers.

This study should set out initiatives which improve and provide new amenity space (and enhanced existing) to make area more attractive.

For local / regional projects (which projects in Park Royal are likely to fall within), the GLA, TfL and London LEAP are the potential sources of funding.

Industrial intensification is currently an area of significant interest to the GLA. As such the next round of GLA regeneration funding, the Good Growth Fund (to be launched in June 2017) is likely to encourage and potentially provide funding for projects which test / pilot industrial intensification projects, particularly those located within London SIL.

Delivery of public realm and or supporting infrastructure could be a component of this.

Boroughs in other parts of London are exploring options to pilot / test industrial intensification models – particularly where they benefit from local land ownership.

A number of models for delivery are being explored:

- Partnership working with private sector landowners to facilitate delivery of new intensification models
- Use of GLA funding to enable intensification of council owned sites
- Use of wider funding (e.g.. core council funding, Business Rates income, New Homes Bonus) to enable council led redevelopment of council owned sites, on the premise of future commercial and financial income generation.

### Promote

The role played by OPDC in collating data and making this easily available is key to encouraging intensification strategies to come forward.

This can form the basis for innovative solutions through showing the demand for types and combinations of space that are perhaps not yet common in Park Royal, and demonstrating where efficiencies can

be found that lead to more effective, viable industrial typologies.

Some actors who have the capacity and interest in delivering intensification strategies may not be currently active in Park Royal, and the OPDC could play a role in promoting the findings of this report to a wider audience. Consultations raised the requirement for developers who aren't currently operating in Park Royal to deliver the typologies proposed in this report.

This could take the form of facilitating collaboration and joint-ventures between landowners, developers and workspace providers, or through soft marketing and workshops based around the approaches outlined in this report.

Business or sector specific representative group(s) could be encouraged to act as point of contact and to orchestrate the coordination between businesses intensification requires and organise the ongoing management of security and public space in the area. This is likely to lead to enhanced satisfaction of existing and prospective business occupiers.

Due to the diversity in the scale and type of business in Park Royal, there may be a number of areas/initiatives that would benefit from coordination.

## 6 Delivery

### 6.2 Recommended Next Steps

#### Decant

The study shows that comprehensive development is both more feasible and viable. Keeping businesses in Park Royal is a concern so should be allowed for through encouraging incremental intensification.

This is reflected in the perception from stakeholder consultation that demand for smaller units is coming from within Park Royal, whereas demand for larger units is generated from outside Park Royal.

Continuing business operations during any redevelopment is a significant constraint on incremental redevelopment. OPDC and private landowners should investigate the possibility of providing space for temporary decant, either within Park Royal or on land along Victoria Road/HS2 work sites where possible. Provision of new intensified space in new developments in Park Royal and Victoria Road/HS2 work sites can help with this.

The specification of this space should be consistent with the areas of focus identified above, such as the dense industrial space along Standard Road, Minerva Road and Chase Road, or the larger sites that would be suitable for large multi-storey industrial development. Making such space available at preferential rates for a temporary

relocation has the potential to unlock sites for incremental development whilst retaining businesses within the area.

#### Future Flexibility

Further monitoring of demand over time should also be carried out to ensure the intelligence is at hand to approach intensification in a flexible way as market and sector demand evolves and changes.

This would ensure that the type of space on offer and amenities continue to attract and retain businesses to Park Royal.

# Appendix A

## Identifier Maps and Sites

# A Identifier Maps and Sites

## A.1 Site Identification

### A.1.1 Spatial Intensification: Extensions/ Infill

#### Area Efficiency

Area Efficiency % =  $\frac{([\text{Site Area}] - [\text{Total Footprint of Buildings}] - [\text{Paved Yard Area}] - [\text{Road Area on Site}])}{([\text{Site Area}]}$

This is any area that is not used productively, relying on the data from the "ILR Data Sites"

#### Key

- 0 - 8%
- 9 - 20%
- 21 - 41%
- 42 - 72%
- 73 - 100%
- Study area boundary

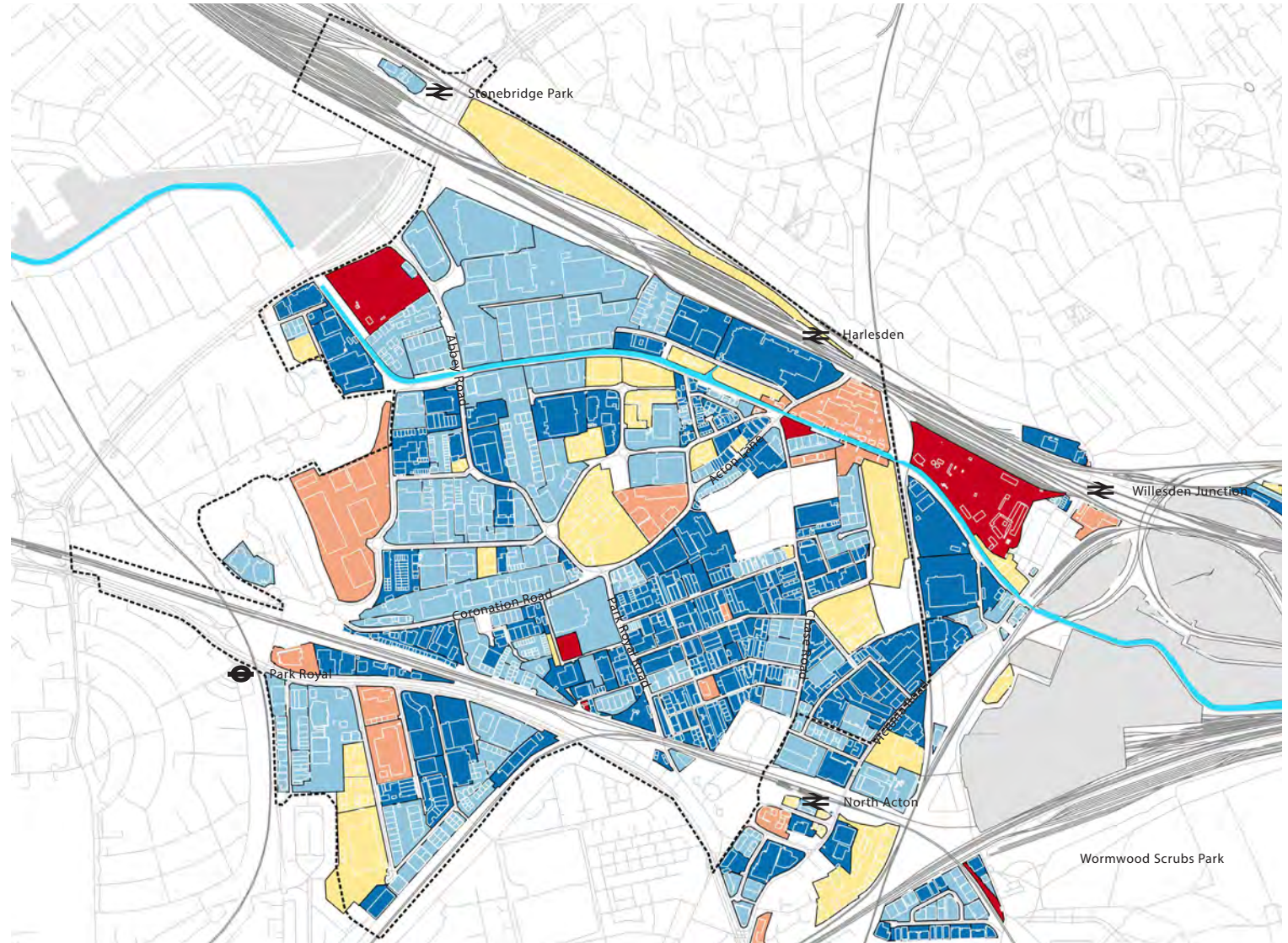

# A Identifier Maps and Sites

## A.1 Site Identification

### A.1.1 Spatial Intensification: Extensions/ Infill

#### Absolute Area Efficiency

Area Efficiency Quantum  
= ([Site Area] - [Total Footprint of Buildings] - [Paved Yard Area] - [Road Area on Site])

#### Key

- <84 sqm
- 84-282 sqm
- 282-629 sqm
- 629-2005 sqm
- 2005+ sqm
- Study area boundary

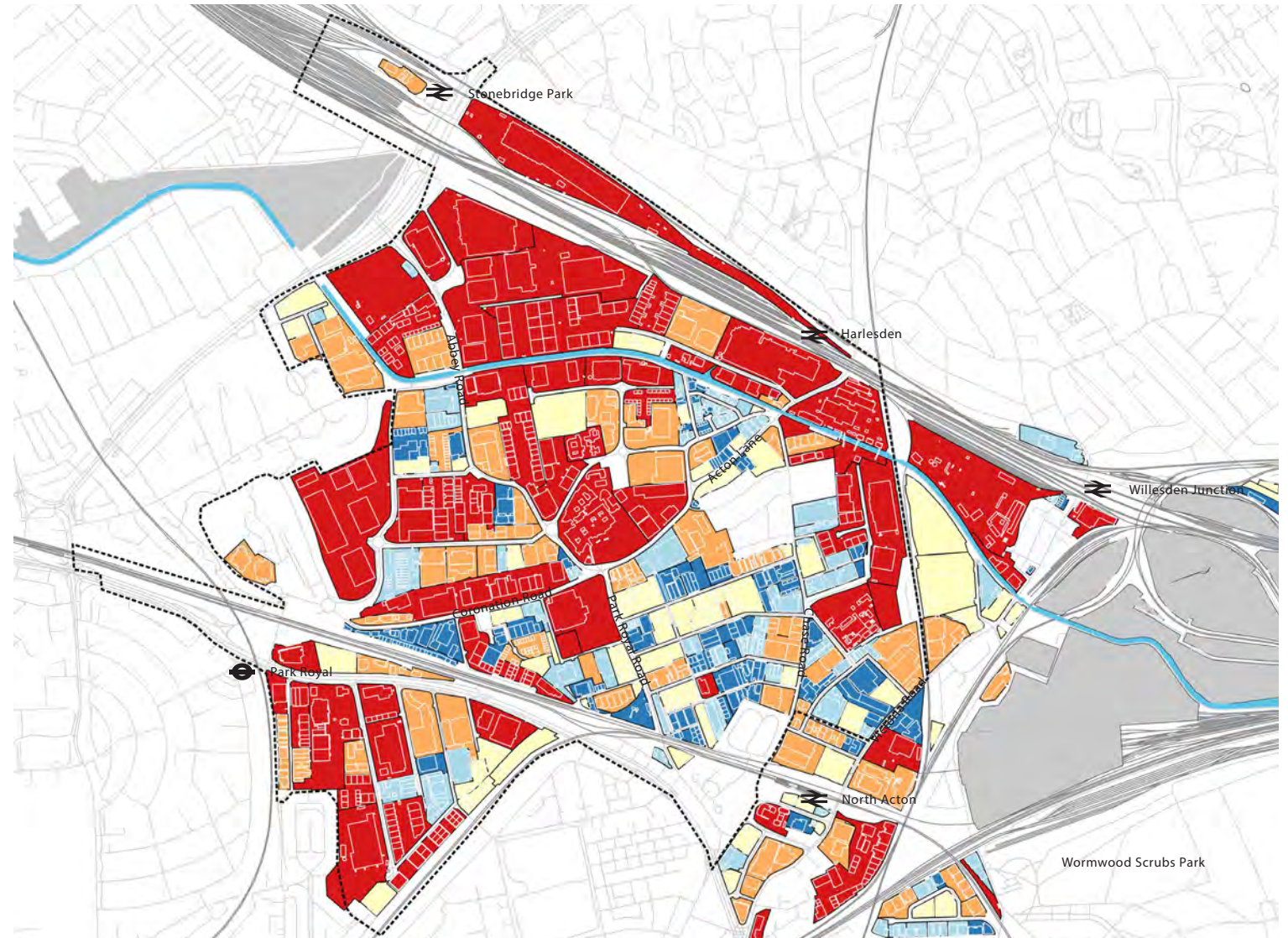

# A Identifier Maps and Sites

## A.1 Site Identification

### A.1.1 Spatial Intensification: Extensions/ Infill

#### Criteria:

**Within site types with low area efficiency % and low absolute area efficiency**

- High residual space not related to operation or security
- For extension, not a modern logistics warehouse (naturally inefficient site geometry)
- Not open industrial land

Example on right:  
6. North Acton Road Ltd.



# A Identifier Maps and Sites

## A.1 Site Identification

### A.1.1 Spatial Intensification: Extensions/ Infill

Selected sites based on low Area Efficiency and meeting selection criteria

#### Key

- Standalone warehouse
- 1. Ryder
- 3. Willen Field Road
- 4. Gorst Road
- 5. Waxlow Road
- 6. North Acton Road Ltd
- 7. Nucleus Business Park
- 8. John Lewis Depot
- Dense industrial
- 19. Park Royal Fire Station
- High street type
- 23. Abbey Manor
- ..... Study area boundary



## A Identifier Maps and Sites

### A.1 Site Identification

#### A.1.1 Spatial Intensification: Extensions/ Infill



8. John Lewis Depot: Potential for infill



5. Waxlow Road: Potential for horizontal extension

# A Identifier Maps and Sites

## A.1 Site Identification

### A.1.2 Spatial Intensification: Vertical Extension

#### Floor Area Ratio (FAR)

Sites with low floor area ratios highlight potential sites where buildings might be extended to make better use of their site area.

Highlights site types with low Floor Area Ratio (FAR)

#### Key

- < 0.30
- 0.30 - 0.60
- 0.60 - 0.80
- 0.80 - 1.20
- 1.20 - 4.50
- ..... Study area boundary

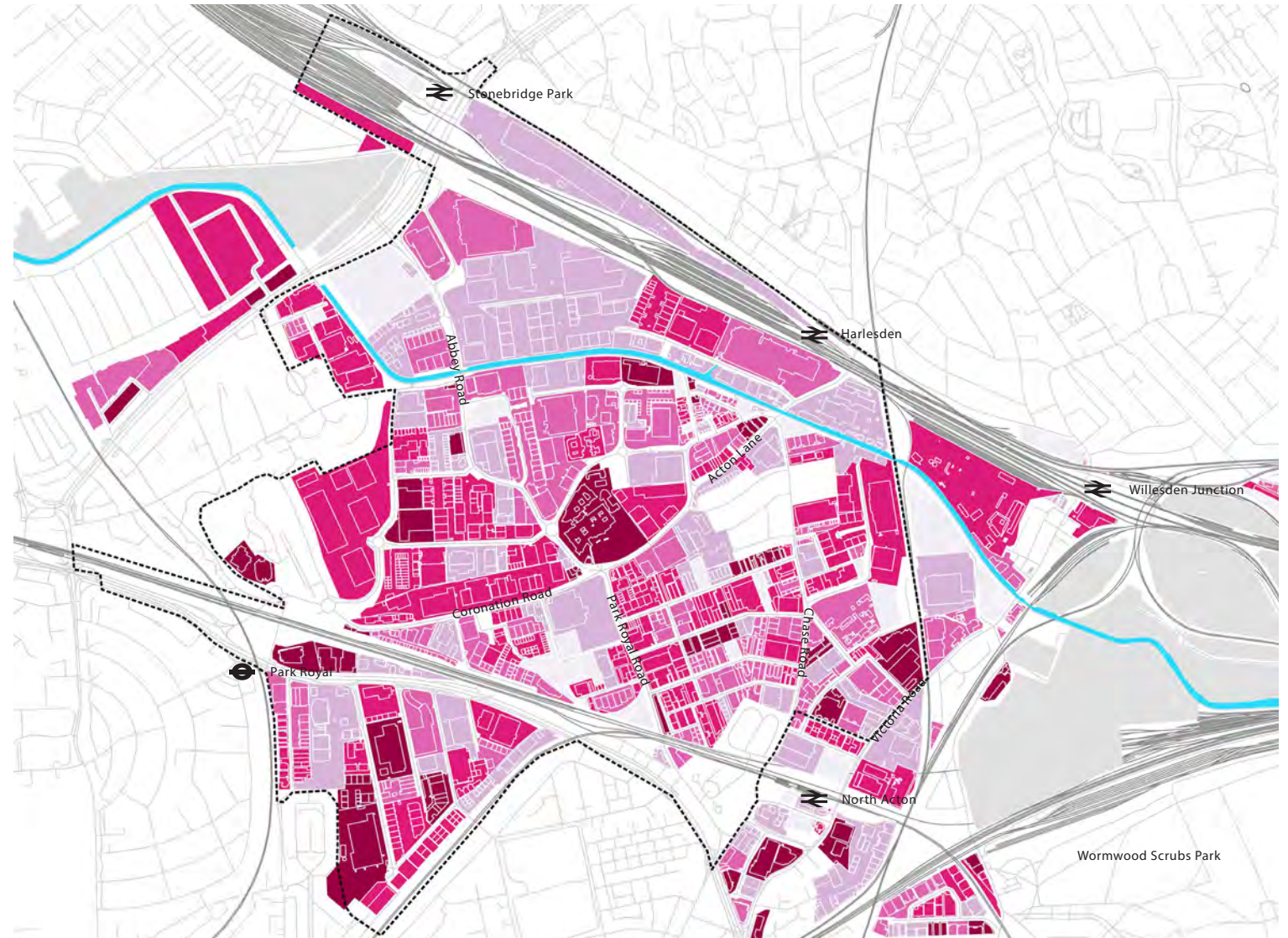

## A Identifier Maps and Sites

### A.1 Site Identification

#### A.1.2 Spatial Intensification: Vertical Extension

##### Criteria

Within site types with  
low FAR (<0.30-0.60)

- Low existing building
- Short structural spans
- No large yard (skews FAR calculation)

Example on right:  
17. Alliance Court



# A Identifier Maps and Sites

## A.1 Site Identification

### A.1.2 Spatial Intensification: Vertical Extension

Selected sites based on low Floor Area Ratio (FAR) and meeting selection criteria

#### Key

- Standalone warehouse
  - 2. HSS Hire
  - 3. Willen Field Road
  - 5. Waxlow Road
- Industrial estate
  - 12. 97 Victoria Road
- Dense industrial
  - 15. Park Royal Fire Station
  - 16. 40 Minerva Rd
  - 17. Alliance Court
- Business centre
  - 21. (7-11) Minerva Road
- ..... Study area boundary

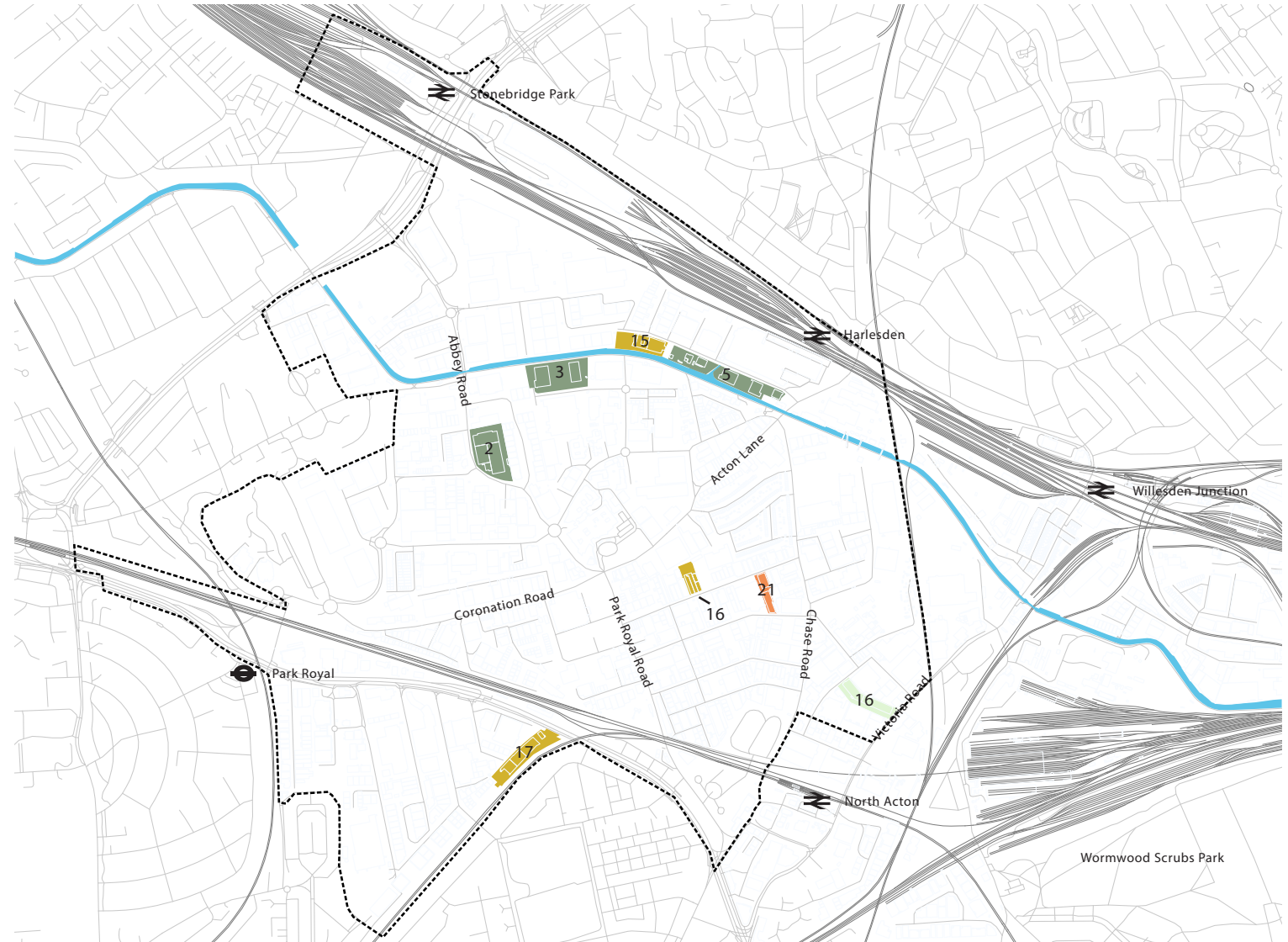

## A Identifier Maps and Sites

### A.1 Site Identification

#### A.1.2 Spatial Intensification: Vertical Extension



12. Alpha Bentre Centre: Potential for vertical extension



2. HSS Hire: Potential for vertical extension

# A Identifier Maps and Sites

## A.1 Site Identification

### A.1.3 Spatial Intensification: Internal Sub-Divisions

#### Volume Efficiency

Volume Efficiency =  
[Volume of Building] / [GEA]  
This results in gross floor level heights. Data is based on GEA figures from the "ILR Data Business" and mean building heights from EMU analytics

In theory floor heights from 7.5 metres onwards allow a mezzanine level for intensification.

#### Key

- 0 - 3.5
- 3.6 - 7.5
- 7.6 - 10.5
- 10.6 - 14
- 14.1 - 17.5
- 17.6 - 21
- 21 +
- ..... Study area boundary

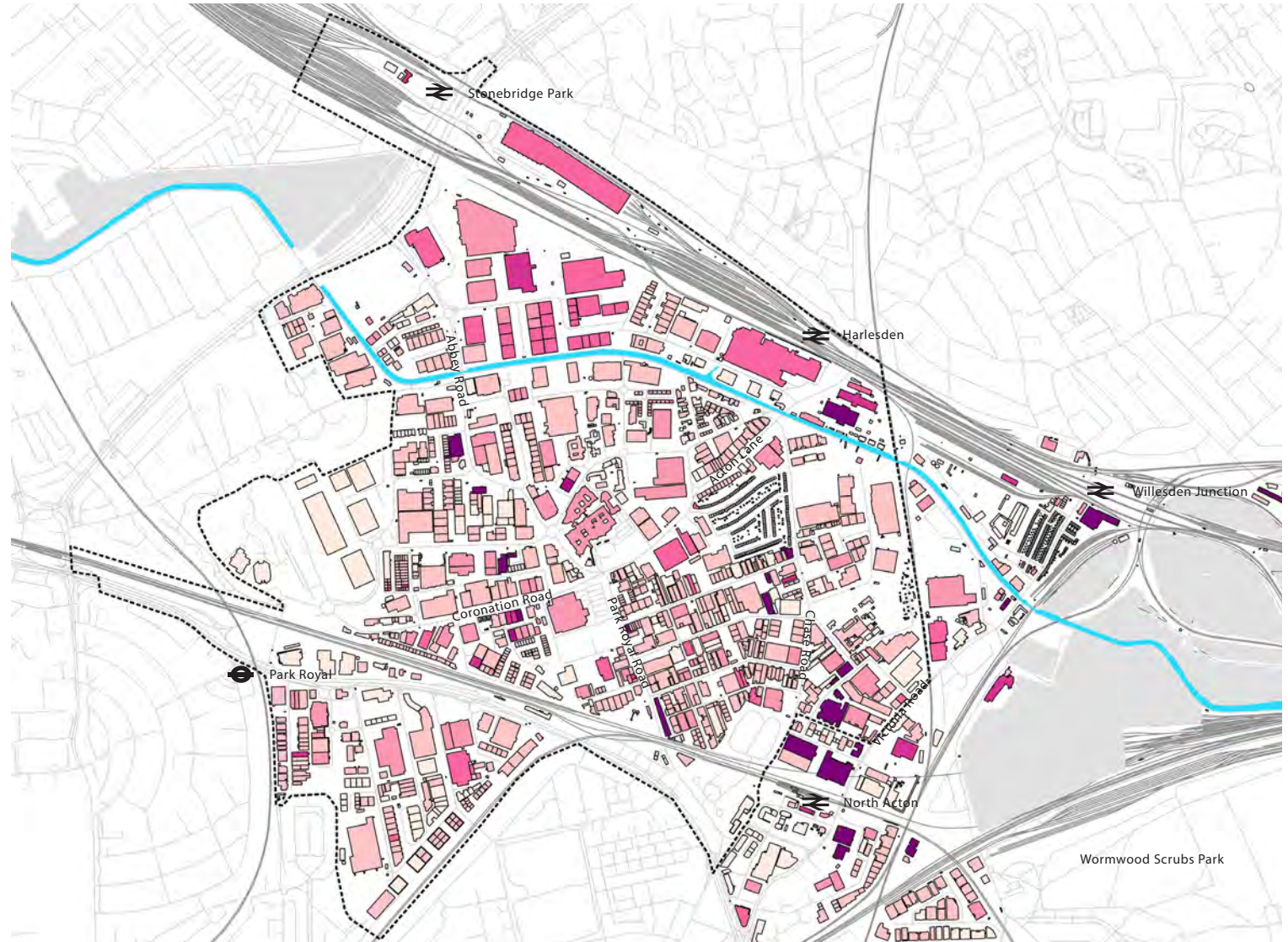

# A Identifier Maps and Sites

## A.1 Site Identification

### A.1.3 Spatial Intensification: Internal Sub-Divisions

#### Criteria:

Within floor heights of  
7.5 metres onwards

- Large, standardised buildings
- No owner occupier
- Single storey

Example on right:  
22. Premier Park



# A Identifier Maps and Sites

## A.1 Site Identification

### A.1.3 Spatial Intensification: Internal Sub-Divisions

Selected sites based on low Volume Efficiency and meeting selection criteria

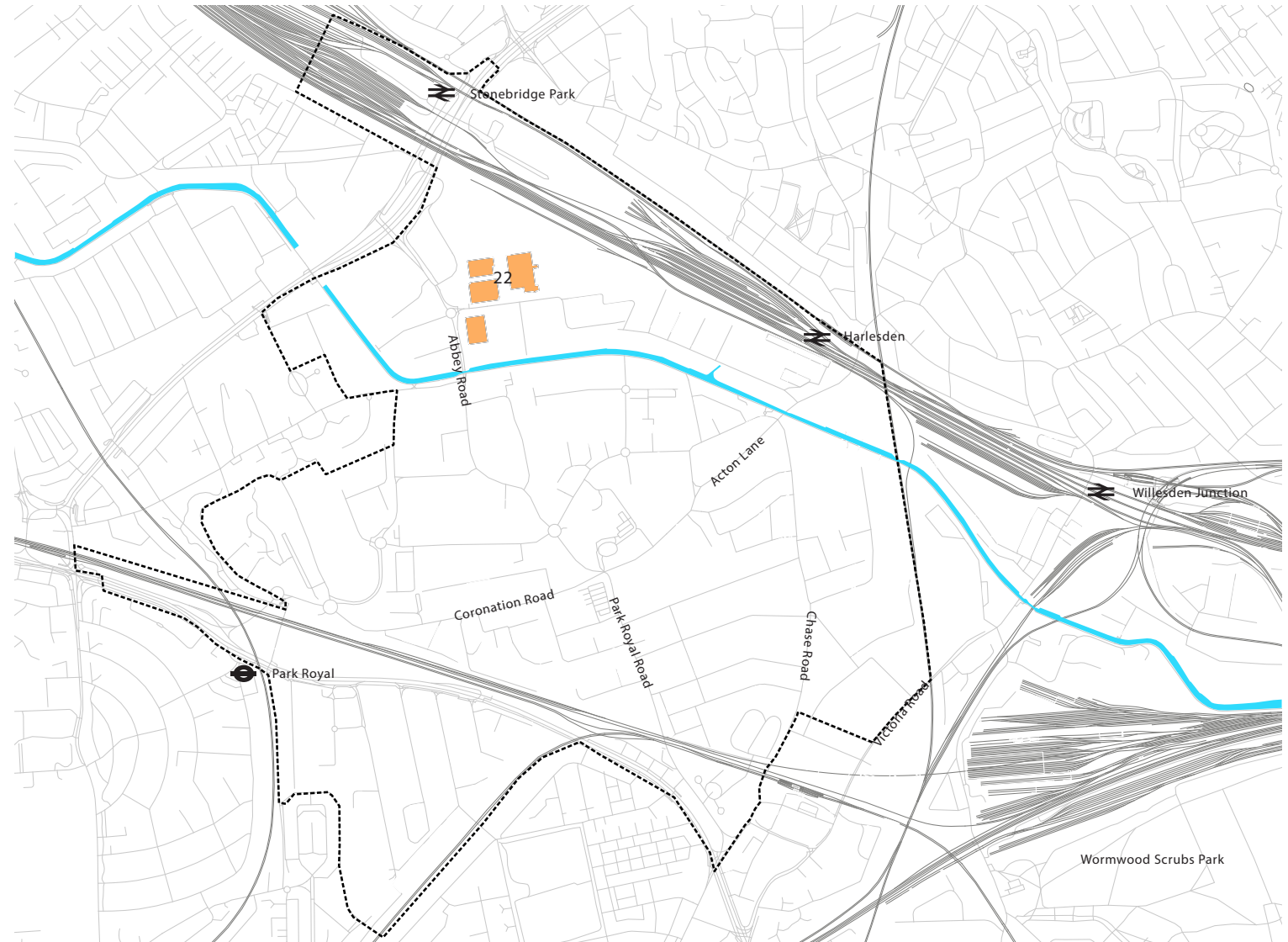

#### Key

- Large warehouse
- 22. Premier Park
- ..... Study area boundary

# A Identifier Maps and Sites

## A.1 Site Identification

### A.1.4 Spatial Intensification: New provision through comprehensive development

#### Buildings per freehold

Calculated using ownership boundaries and buildings as mapped by the Park Royal IRL.

#### Key

- 0 - 1
- 1 - 5
- 5 - 8
- 8 - 15
- 15 +

..... Study area boundary

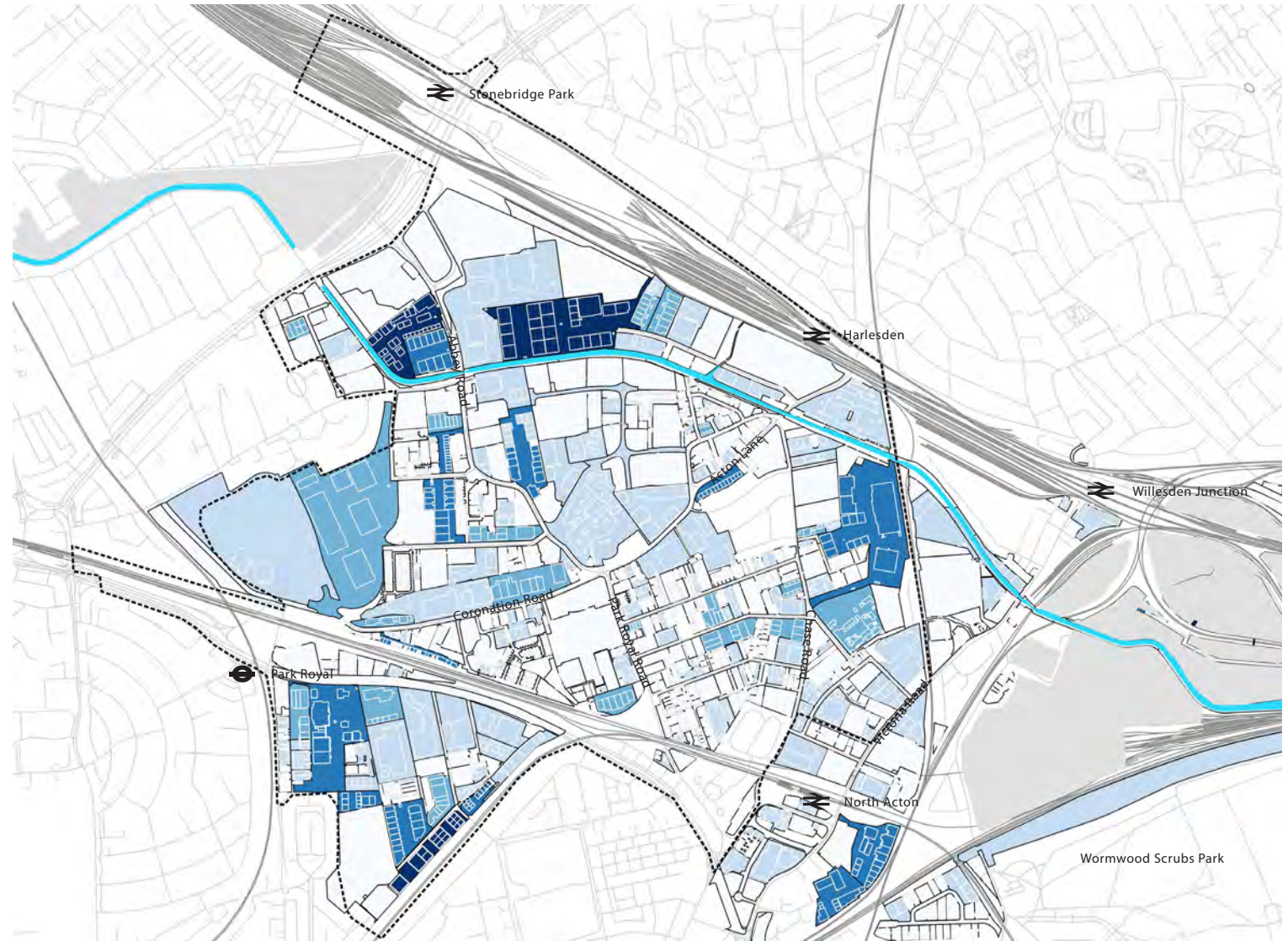

# A Identifier Maps and Sites

## A.1 Site Identification

### A.1.4 Spatial Intensification: New provision through comprehensive development

#### Criteria:

- Old stock
- Larger, geometrically simple sites
- Single or few ownerships on site

Example, right:

10. Space Industrial Estate



# A Identifier Maps and Sites

## A.1 Site Identification

### A.1.4 Spatial Intensification: New provision through comprehensive development

Selected sites based on ownership boundaries and meeting selection criteria

#### Key

- Standalone warehouse  
11. Bush Industrial Estate
- Industrial estate  
9. Grand Union Industrial Estate  
10. Space Business Park  
11. Bush Industrial Estate  
13. Kendal Court  
14. Westwood Park
- ..... Study area boundary



## A Identifier Maps and Sites

### A.1 Site Identification

#### A.1.4 Spatial Intensification: New provision through comprehensive development



14. Westwood Park



11. Bush Industrial Estate

# A Identifier Maps and Sites



## A.1 Site Identification

### A.1.5 Spatial Intensification: New provision on vacant sites

#### Vacancy

Current vacancy of sites identified as vacant at the time of the Park Royal Atlas

#### Key

-  Buildings and sites that remain vacant
-  Buildings and sites that are no longer vacant
-  Study area boundary



# A Identifier Maps and Sites

## A.1 Site Identification

### A.1.5 Spatial Intensification: New provision on vacant sites

#### Criteria:

- Large area (not small, individual buildings or freeholds)
- Currently still vacant (since Park Royal mapping)
- Ownership boundaries

Example, right:  
18. Twyford Tip



# A Identifier Maps and Sites

## A.1 Site Identification

### A.1.5 Spatial Intensification: New provision on vacant sites

Selected sites based on current vacancy and meeting selection criteria



#### Key

- Open industrial land
  - 18. Twyford Tip
  - 19. 54A Minerva Road
  - 20. Western Road
- Vacant lot
  - 24. Bashley Road
- ..... Study area boundary

## Appendix B Site Long List

**Sites have been identified by a series of data-driven indicators and selection criteria based on their suitability for industrial intensification.**

B.1 Locations

B.2 Site Comments

B.3 Sites by Site Type

B.4 Sites by Intensification Type

B.5 Sites

# B Long List

## B.1 Locations

### Long List Sites

Sites identified through the indicators (see appendix A) make up a long list of site that are suitable for intensification due to their spatial characteristics and/or ownership structure.

This long list has been analysed closely through site observation to determine the spatial, commercial and delivery potential on each site, identifying which sites would be appropriate for case study designs. These case studies are those where redevelopment is likely to be viable under current market conditions, are typical site conditions found across Park Royal.

#### Key

- Case Study Sites
- OPDC Area
- Park Royal Intensification Study Area boundary
- Borough Boundaries

- |                           |                            |                         |
|---------------------------|----------------------------|-------------------------|
| 1 Ryder, Abbey Road       | 12 97 Victoria Road        | 23 Bashley Road         |
| 2 HSS, Abbey Road         | 13 Kendal Court            | 24 Origin Business Park |
| 3 Willen Field Road       | 14 Westwood Park           |                         |
| 4 Gorst Road              | 15 Park Royal Fire Station |                         |
| 5 Waxlow Road             | 16 40-54A Minerva Road     |                         |
| 6 North Acton Road        | 17 Alliance Court          |                         |
| 7 Nucleus Business Park   | 18 Twyford Tip             |                         |
| 8 John Lewis Depot        | 19 Western Road            |                         |
| 9 Grand Union Trading     | 20 (7-11) Minerva Road     |                         |
| 10 Space Business Park    | 21 Premier Park            |                         |
| 11 Bush Industrial Estate | 22 Abbey Manor             |                         |

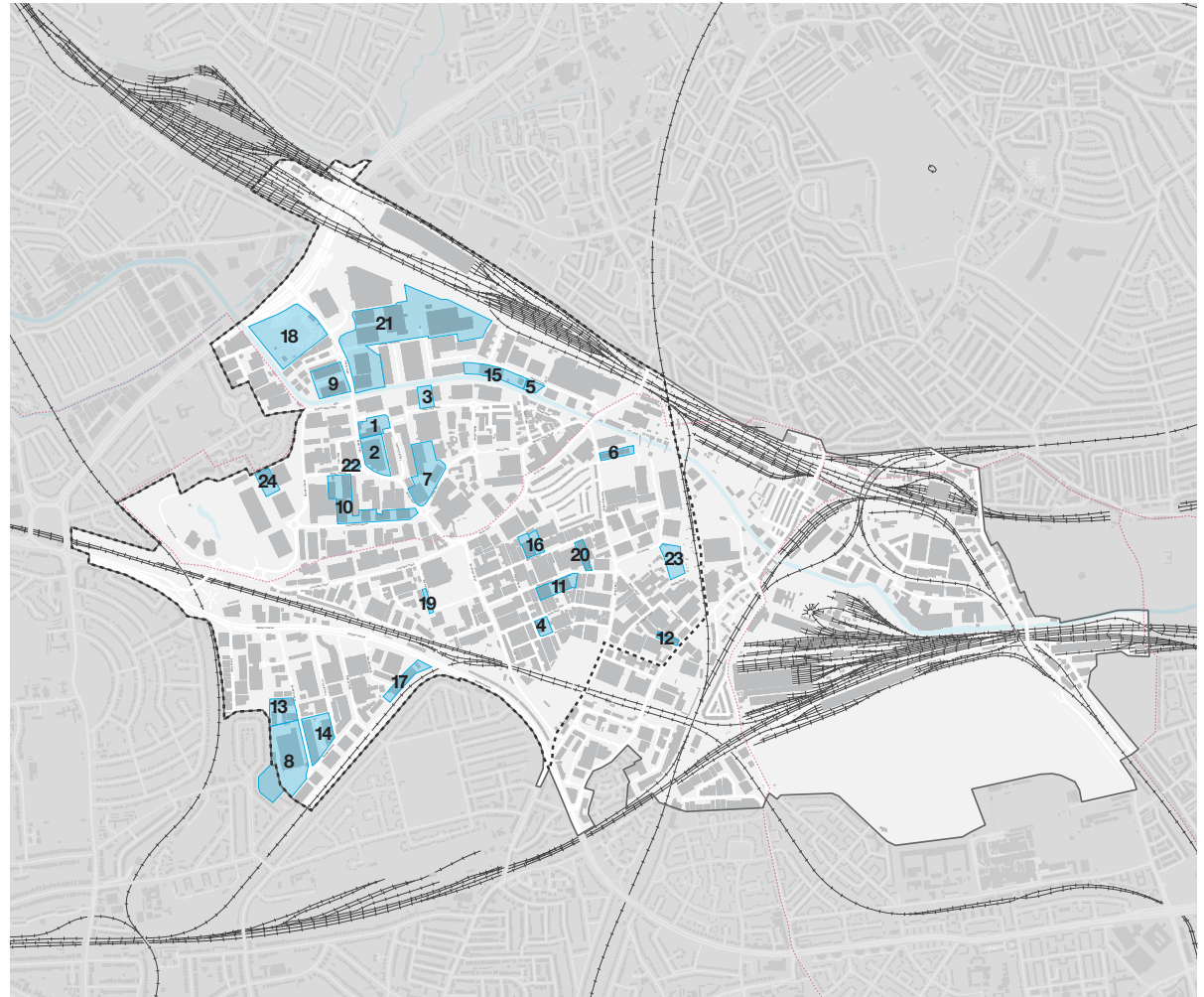

# B Long List

## B.2 Site Comments

Site	Spatial Comments	Commercial Comments	Deliverability Comments	Case Study
Ryder, Abbey Road	Intensification relies on retaining operation of yard as vehicle hire	-	-	No
HSS, Abbey Road	Little scope to separate entrances, existing building poor quality	Viability unlikely due to minimal scope for incorporating higher value space	-	No
Willen Field Road	Proportions and size of site make intensification potentially feasible	-	Vacant site likely to be developed	Yes
Gorst Road	-	Location appropriate for higher value uses	Underutilised site likely to be developed	Yes
Waxlow Road	-	Existing building with heritage value, proximity to canal attractive to occupiers	-	Yes
North Acton Road	Location appropriate for increase in employment densities, heritage quality could attract tenants	-	-	Yes
Nucleus Business Park	Little scope for significant increase in employment space	Existing buildings modern and high quality	-	No
John Lewis Depot	-	-	Poor access to space and proximity to residential area not appropriate	No
Grand Union Trading Estate	Space intensively used for trade warehousing	-	-	No
Space Business Park	-	Existing buildings modern and high quality	-	No
Bush Industrial Estate	-	Older building stock could make comprehensive development viable, location good for certain uses	Single ownership makes phased redevelopment possible	No
97 Victoria Road	-	Location good for higher value uses	Existing occupier undertaking intensification scheme	Yes
Kendal Court	-	Existing buildings modern and high quality	-	No

# B Long List

## B.2 Site Comments

Site	Spatial Comments	Commercial Comments	Deliverability Comments	Case Study
Westwood Park	-	Existing buildings modern and high quality	-	No
Park Royal Fire Station	-	-	Existing use not feasible for mix of uses	No
40-54A Minerva Road	Potential for improved efficiency of space when developed as single plot	-	-	Yes
Alliance Court	Little scope for significant increase in employment space	Increase in employment space not likely to justify retaining existing building	-	No
Twyford Tip	Large vacant site with potential for intensification	High land remediation costs likely to challenge viability	Extant planning permission for mixed use development	No
Western Road	Proportions of site make industrial typologies challenging	-	Vacant site is potential for redevelopment	No
(7-11) Minerva Road	Significant increase in storeys possible given current use and building structure	-	-	Yes
Premier Park	-	-	Building has been un-let for some time	No
Abbey Manor	-	-	Space on site currently used for event space	No
Bashley Road	Limited access to site	Surrounding uses which may limit occupiers	-	Yes
Origin Business Park	-	-	Building has been un-let for some time	Yes

# B Long List

## B.3 Sites by Site Type

Site	Standalone Warehouse	Industrial Estate	Dense Industrial	Open Industrial Land	Business Centre	High Street Type	Vacant Lot
Ryder, Abbey Road	●						
HSS, Abbey Road	●						
Willen Field Road	●						
Gorst Road	●						
Waxlow Road	●						
North Acton Road	●						
Nucleus Business Park	●						
John Lewis Depot	●						
Grand Union Trading Estate		●					
Space Business Park		●					
Bush Industrial Estate		●					
97 Victoria Road		●					
Kendal Court		●					
Westwood Park		●					
Park Royal Fire Station			●				
40-54A Minerva Road			●				
Alliance Court			●				
Twyford Tip				●			
Western Road				●			
(7-11) Minerva Road					●		
Premier Park Road					●		
Abbey Manor						●	
Bashley Road							●
Origin Business Park	●						

# B Long List

## B.4 Sites by Intensification Type

Site	Horizontal Extension/Infill	Vertical Extension	Internal Sub-Division	Comprehensive Redevelopment	New Development on Vacant Land
Ryder, Abbey Road	●				
HSS, Abbey Road		●			
Willen Field Road	●				
Gorst Road				●	
Waxlow Road	●				
North Acton Road	●				
Nucleus Business Park	●				
John Lewis Depot	●				
Grand Union Trading Estate				●	
Space Business Park				●	
Bush Industrial Estate				●	
97 Victoria Road		●			
Kendal Court				●	
Westwood Park				●	
Park Royal Fire Station	●				
40-54A Minerva Road					●
Alliance Court		●			
Twyford Tip					●
Western Road					●
(7-11) Minerva Road		●			
Premier Park Road			●		
Abbey Manor	●				
Bashley Road					●
Origin Business Park			●		

# B Long List

## B.5 Sites

### B.5.1 Ryder

#### Case Study - Area 1: Ryder

Abbey Road, NW10 7SJ

Site type: Standalone Warehouse  
Building type: Small office + Yard  
Business: Ryder PLC

Site area: 9,031m<sup>2</sup>  
Building footprint: 2,264m<sup>2</sup>  
F.A.R.: 0.26

Intensification type: Infill



# B Long List

## B.5 Sites

### B.5.2 HSS Hire

#### Case Study - Area 1: Ryder

19 Abbey Road, NW10 7SJ

Site type: Standalone Warehouse  
Building type: Large Industrial  
Business: HSS Hire

Site area: 16,574m<sup>2</sup>  
Building footprint: 8,717m<sup>2</sup>  
F.A.R.: 0.57

Intensification type:  
Vertical Extension



## B Long List

### B.5 Sites

#### B.5.3 Willenfield Road

##### Case Study - Area 3: Willenfield

4-6 Willenfield Road, NW10 7AQ

Site type: Vacant  
Building type: n/a  
Business: n/a

Site area: 4,978m<sup>2</sup>  
Building footprint: Site only  
F.A.R.: 0

Intensification type:  
New provision on vacant site



## B Long List

### B.5 Sites

#### B.5.4 Gorst Road

##### Case Study - Area 4: Gorst Road

37 Gorst Road, NW10 6LA

Site type: Standalone Warehouse

Site area: 3,847m<sup>2</sup>

Intensification type:

Building type: Large Industrial

Building footprint: 1,145m<sup>2</sup>

Comprehensive development

Business: -

F.A.R.: 0.30



## B Long List

### B.5 Sites

#### B.5.5 Waxlow Road

##### Case Study - Area 5: Waxlow

7-21 Waxlow Road, NW10

Site type: Standalone Warehouse  
Building type: Large Industrial  
Business: Crest

Site area: 2,937m<sup>2</sup>  
Building footprint: 812m<sup>2</sup>  
F.A.R.: 0.45

Intensification type:  
Vertical/Horizontal Extension



## B Long List

### B.5 Sites

#### B.5.6 North Acton Road

##### Case Study - Area 6: North Acton Road

37-39 North Acton Road, NW10 7PF

Site type: Standalone Warehouse  
Building type: Large Industrial  
Business: North Acton Road Ltd

Site area: 5,945m<sup>2</sup>  
Building footprint: 2,004m<sup>2</sup>  
F.A.R.: 0.63

Intensification type:  
Horizontal Extension



## B Long List

### B.5 Sites

#### B.5.7 Nucleus Business Park

##### Case Study - Area 7: Nucleus Business Park, City Link

2 Central Way, NW10 7XT

Site type: Industrial Estate  
Building type: Large Industrial  
Business: Multiple

Site area: 23,743m<sup>2</sup>  
Building footprint: 10,920m<sup>2</sup>  
F.A.R.: 0.57

Intensification type:  
Horizontal Extension



# B Long List

## B.5 Sites

### B.5.8 John Lewis Depot

#### Case Study - Area 8: John Lewis Depot

Kendal Avenue, W3 OTP

Site type: Standalone Warehouse  
Building type: Large Industrial  
Business: John Lewis

Site area: 44,242m<sup>2</sup>  
Building footprint: 13,004m<sup>2</sup>  
F.A.R.: 0.88

Intensification type:  
Infill



# B Long List

## B.5 Sites

### B.5.9 Grand Union Industrial Estate

#### Case Study - Area 9: Grand Union Industrial Estate

Abbey Road, NW10 7UL

Site type: Industrial Estate  
Building type: Small Industrial  
Business: Multiple

Site area: 17,041m<sup>2</sup>  
Building footprint: 8,741m<sup>2</sup>  
F.A.R.: 0.72

Intensification type:  
Comprehensive development



# B Long List

## B.5 Sites

### B.5.10 Space Business Park

#### Case Study - Area 10: Space Business Park - Cumberland Avenue Business Park

Abbey Road/Cumberland Avenue, NW10 7SU

Site type: Industrial Estate  
Building type: Large Industrial  
Business: Multiple

Site area: 27,405m<sup>2</sup>  
Building footprint: 14,653m<sup>2</sup>  
F.A.R.: 0.88

Intensification type:  
Comprehensive Development



# B Long List

## B.5 Sites

### B.5.11 Bush Industrial Estate

#### Case Study - Area 11: Bush Industrial Estate

Standard Road, NW10 6DF

Site type: Industrial Estate  
Building type: Large Industrial  
Business: Multiple

Site area: 9,497m<sup>2</sup>  
Building footprint: 10,635m<sup>2</sup>  
F.A.R.: 1.13

Intensification type:  
Comprehensive development



## B Long List

### B.5 Sites

#### B.5.1297 Victoria Road

##### Case Study - Area 12: 97 Victoria Road

97 Victoria Road, NW10 6SX

Site type: Industrial Estate  
Building type: Large Industrial  
Business: Foxtons

Site area: 3,719m<sup>2</sup>  
Building footprint: 1,974m<sup>2</sup>  
F.A.R.: 0.55

Intensification type:  
Vertical Extension



# B Long List

## B.5 Sites

### B.5.13 Kendal Court

#### Case Study - Area 13: Kendal Court

Kendal Avenue, W3 0RU

Site type: Industrial Estate  
Building type: Small Industrial  
Business: Multiple

Site area: 10,635m<sup>2</sup>  
Building footprint: 5,103m<sup>2</sup>  
F.A.R.: 0.90

Intensification type:  
Comprehensive development



# B Long List

## B.5 Sites

### B.5.14 Westwood Park

#### Case Study - Area 14: Westwood Park

Concord Road, W3 0TH

Site type: Industrial Estate  
Building type: Small Industrial  
Business: Multiple

Site area: 19,513m<sup>2</sup>  
Building footprint: 9,379m<sup>2</sup>  
F.A.R.: 0.87

Intensification type:  
Comprehensive development



# B Long List

## B.5 Sites

### B.5.15 Park Royal Fire Station

#### Case Study - Area 15: Park Royal Fire Station

21 Waxlow Road, NW10 7NU

Site type: Open Industrial Land  
Building type: Yard  
Business: PR Fire Station

Site area: 8,204m<sup>2</sup>  
Building footprint: 3,657m<sup>2</sup>  
F.A.R.: 0.45

Intensification type:  
Vertical/Horizontal Extension



## B Long List

### B.5 Sites

#### B.5.16 Minerva Road

##### Case Study - Area 16: Minerva Road

40 Minerva Road, NW10 6HJ

Site type: Dense Industrial  
Building type: Large Industrial  
Business: SPC Automotive

Site area: 4,132m<sup>2</sup>  
Building footprint: 2,293m<sup>2</sup>  
F.A.R.: 0.46

Intensification type:  
Vertical Extension

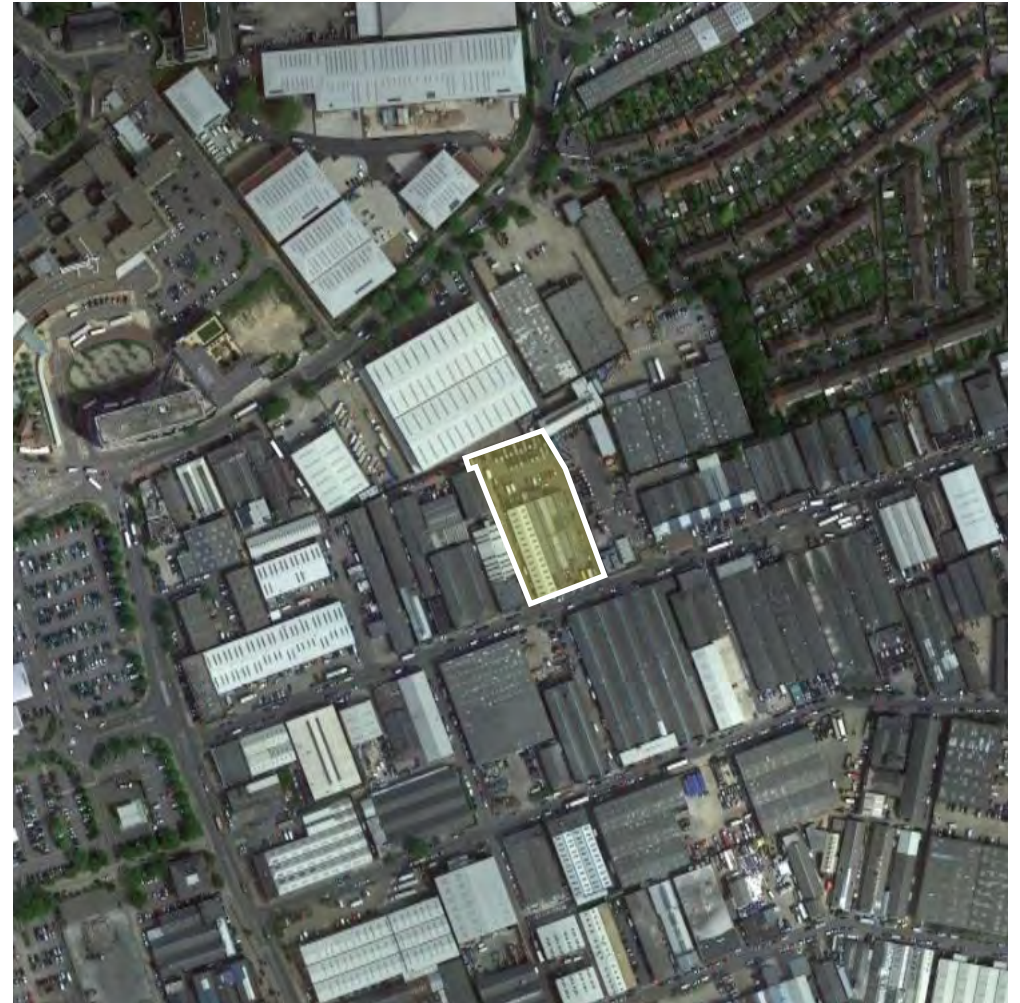

## B Long List

### B.5 Sites

#### B.5.17 Alliance Court

##### Case Study - Area 17: Alliance Court

Alliance Court, Alliance Road

Site type: Dense Industrial  
Building type: Small Industrial  
Business: Multiple

Site area: 11,517m<sup>2</sup>  
Building footprint: 4,538m<sup>2</sup>  
F.A.R.: 0.47

Intensification type:  
Vertical Extension



# B Long List

## B.5 Sites

### B.5.18 Twyford Tip

#### Case Study - Area 18: Twyford Tip

703 Abbey Road, NW10 7UW

Site type: Vacant Lot

Building type: Yard

Business: Brent Recycling Centre

Site area: 48,009m<sup>2</sup>

Building footprint: 304m<sup>2</sup>

F.A.R.: 0.01

Intensification type:

New provision on vacant land



## B Long List

### B.5 Sites

#### B.5.1954A Minerva Road

##### Case Study - Area 19: Minerva 54A

54A Minerva Road, NW10 6HJ

Site type: Vacant lot  
Building type: Yard  
Business: -

Site area: 3,736m<sup>2</sup>  
Building footprint: 0m<sup>2</sup>  
F.A.R.: 0.00

Intensification type:  
New provision on vacant land



# B Long List

## B.5 Sites

### B.5.20 Western Road

#### Case Study - Area 20: Western Road

17 Western Road, NW10 7LT

Site type: Vacant lot  
Building type: Yard  
Business: -

Site area: 5,037m<sup>2</sup>  
Building footprint: 0m<sup>2</sup>  
F.A.R.: 0.00

Intensification type:  
New provision on vacant land



## B Long List

### B.5 Sites

#### B.5.21 (7-11) Minerva Road

##### Case Study - Area 21: (7-11) Minerva Road

7-11 Minerva Road, NW10 6HJ

Site type: Business Centre

Site area: 4,775m<sup>2</sup>

Intensification type:

Building type: Studio/Workshop

Building footprint: 2,004m<sup>2</sup>

Vertical Extension

Business: Multiple

F.A.R.: 0.63



# B Long List

## B.5 Sites

### B.5.22 Premier Park

#### Case Study - Area 22: Premier Park

Premier Park Road, NW10 7NZ

Site type: Business Centre  
Building type: Large Industrial  
Business: Multiple

Site area: 113,943m<sup>2</sup>  
Building footprint: 43,462m<sup>2</sup>  
F.A.R.: 0.45

Intensification type:  
Internal Subdivision



# B Long List

## B.5 Sites

### B.5.23 Abbey Manor

#### Case Study - Area 23: Abbey Manor

28 Abbey Road, NW10 7SB

Site type: Standalone Warehouse  
Building type: Small office + Yard  
Business: Ryder PLC

Site area: 1,983m<sup>2</sup>  
Building footprint: 400m<sup>2</sup>  
F.A.R.: 0.04

Intensification type:  
Horizontal Extension



## B Long List

### B.5 Sites

#### B.5.24 Bashley Road

##### Case Study - Area 24: Bashley Road

3 Bashley Road, NW10

Site type: Vacant lot  
Building type: Yard  
Business: -

Site area: 10,594m<sup>2</sup>  
Building footprint: 0m<sup>2</sup>  
F.A.R.: 0.00

Intensification type:  
New provision on vacant land



# Appendix C

## Case Studies

# Appendix C

## Case Studies

- C.1 Gorst Road Higher Capacity Option
- C.2 Waxlow Road Higher Capacity Option
- C.3 North Acton Road Higher Capacity Option
- C.4 (7-11) Minerva Road Higher Capacity Option
- C.5 Origin Business Park Higher Capacity Option
- C.6 Site Identification Criteria

# C Case Studies

## High Capacity Case Studies

The following pages set out the design approaches for 5 case study sites which provide the highest capacity on the following sites:

- Gorst Road
- Waxlow Road
- North Acton Road
- (7-11) Minerva Road
- Origin Business Park

The designs reflect the a higher capacity for each site, and could prove to be viable developments in the future under different market conditions. Designs for Waxlow Road and North Acton Road have been improved to create a better relationship between the buildings and the street.

The design approaches have been refined in order to arrive at viable proposals included in section 4.2 through the design alterations set out in the table opposite.

Case Study	Design Alterations
Gorst Road	Quantum of B2/B8 space increased through making yard space suitable for smaller delivery vehicles. Quantum of B1a reduced to 10% of B2/B8 space and B1c removed from upper storeys, removing requirement for goods lifts. Building height limited to 2 storeys with mezzanine level at ground floor.
Waxlow Road	B2/B8 at ground floor extended, site reconfigured to reduce number of goods lifts serving upper storeys. Relationship of building to the street is improved.
North Acton Road	Lighter touch refurbishment of retained building, extensions limited to single storey. Relationship of building to the street is improved.
(7-11) Minerva Road	Due to the quality of the existing building and the size and proportion of the site, the viability position of this site is unlikely to be significantly improved through design alterations.
Origin Business Park	Due to the high quality of the existing building and the rental values for B1a in this location the viability position of this approach is unlikely to be significantly improved through design alterations.

# C Case Studies

## C.1 Gorst Road

### C.1.1 Site Selection

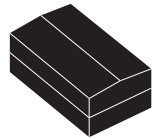

#### Comprehensive Redevelopment

**Address** 37 Gorst Road  
**Postcode** NW10 6LA  
**PTAL** 4

**Boundary** Freehold  
**Business** -  
**Site Type** Standalone Warehouse  
**Building Type** Large Industrial  
**Site Area** 3,847 m<sup>2</sup>  
**Footprint** 1,145 m<sup>2</sup>

#### Development Summary

Total Development Value (GDV)	£ 14.9m
Total Development Cost	£ 11.8m
Residual Land Value (RLV)	£ 1.1m
Estimated Land Cost (EUV)	£ 2.3m
Viable	No

#### Site History

Existing yard area appears to be unused by current occupier. We understand the site was recently the subject of an enquiry by Segro to buy the land.

The site which comprises 9,712 sqft of warehouse space and 3,232 sqft of office space is currently available to let at £285,000.00 per annum.

#### Site Selection

The site is identified as having a poor spatial efficiency. As such, the site is considered to have potential to deliver higher densities of employment on the site.

#### Development Objectives

The size and proportion of the site, with road access on two sides makes larger industrial spaces potentially very efficient. The separation of uses would increase their marketability

The sites location and PTAL also offers an opportunity to incorporate office uses.

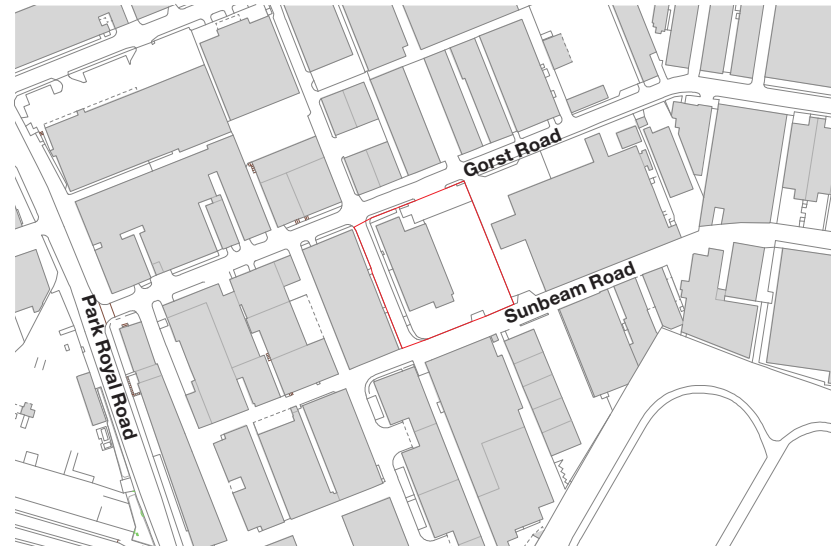
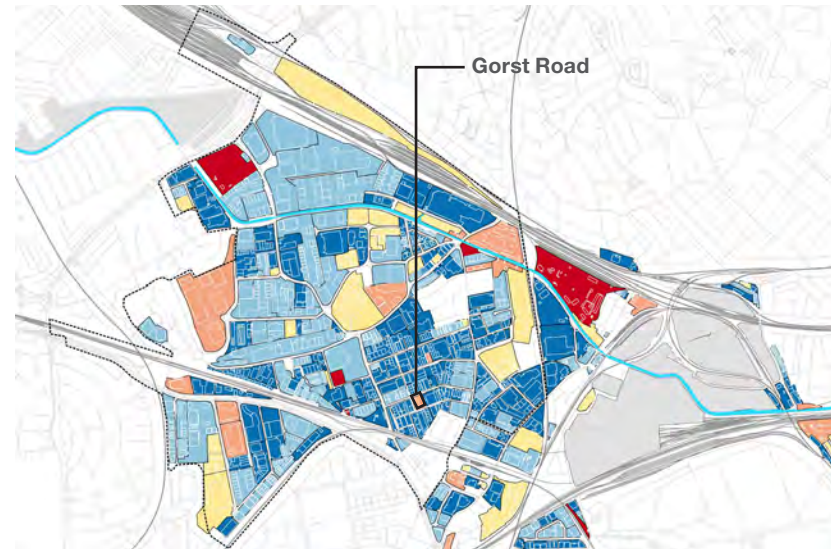

## C Case Studies

### C.1 Gorst Road

#### C.1.2 Existing Site



#### View to south

The existing site looking south from Gorst Road



#### Sunbeam Road

Southern edge of site on Sunbeam Road

# C Case Studies

## C.1 Gorst Road

### C.1.3 Mix and Space Requirements

#### Design Principle 1: Separate Access

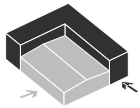

#### Design Principle 2: Stack Uses

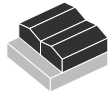

#### Design Principle 4: Exploit Accessibility



#### Design Principle 6: Placemaking

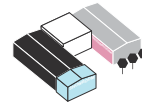

Use Class	Justification
B1a	PTAL and local amenity provide potential for attractive location for B1 uses ancillary to industrial uses on site.
B1c	Location and existing clusters of industries could be appropriate for flexible space for SMEs.
B2/B8	Good access from Gorst Road/Park Royal Road supports high quality industrial space.

Typology	Justification
Medium Warehouse	Access and size of site restricts larger industrial units, but size and proportions of plot can accommodate warehouses.
Studio/Workshop	Site access on three sides allows for servicing to smaller workspaces. Size could allow flexible units.
Small Office	Site access from three sites allows for dedicated access for offices, separate from industrial access.

#### Typology Requirements

For spatial/operational requirements for each typology, please refer to appendix E.

	Key Design Considerations
Place making	Focussing B1 uses on Sunbeam Road could, combined with similar initiatives along the road create a positive environment on the route to North Acton Station
Viability	Although the site has good PTAL, viability of B1 uses are challenging in this location due to the urban environment being prohibitive of businesses locating here.
Employment Density	Introducing higher employment densities at ground floor through B1c and provision of B1a space can exploit the location at good PTAL to provide an uplift in densities.

## C Case Studies

### C.1 Gorst Road

#### C.1.4 Precedents



#### Workshop/Atelier (Spike Island, Bristol)

Consolidation of B1 uses on certain streets can create positive environments, improving the marketability of multilevel B1 space



#### Kaap Nord

Offices above workshops, with service access



#### Mezzanine

Mezzanine levels provide significant increase in warehouse spaces.

# C Case Studies

## C.1 Gorst Road

### C.1.5 Schematic Design

**Summary**  
**The design delivers 275% increase of overall floorspace, creating a positive frontage onto Sunbeam Road**

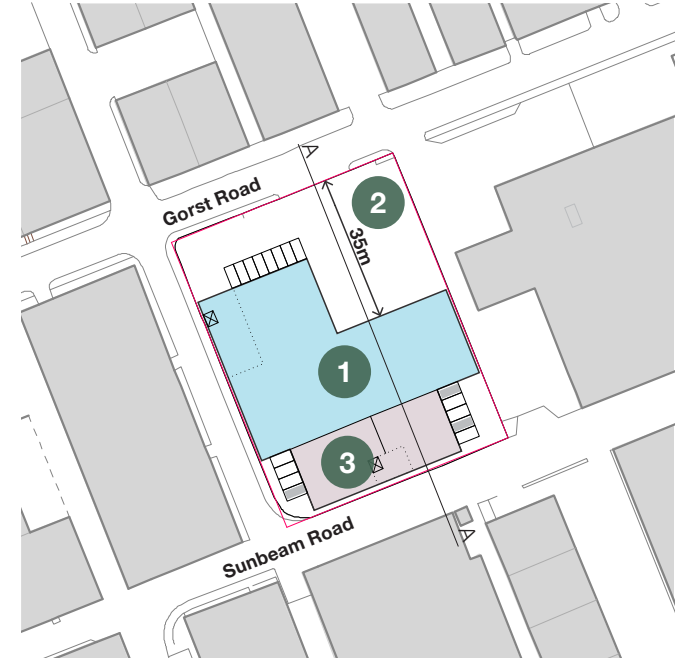
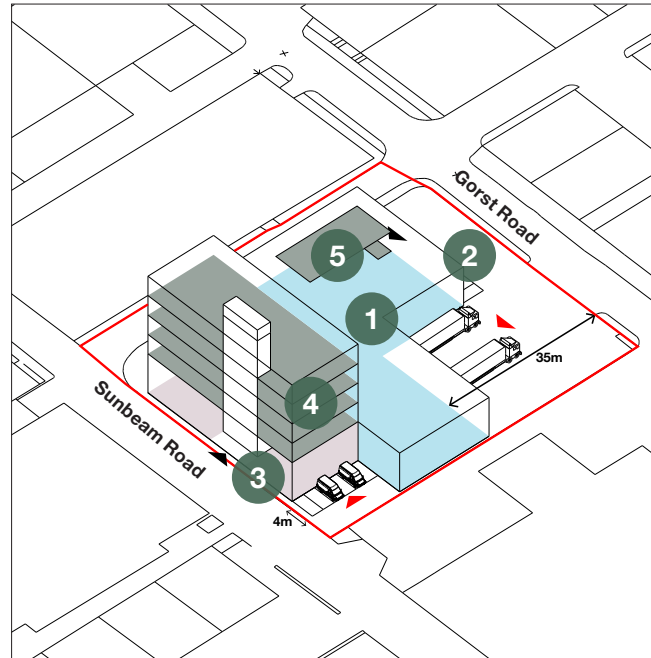
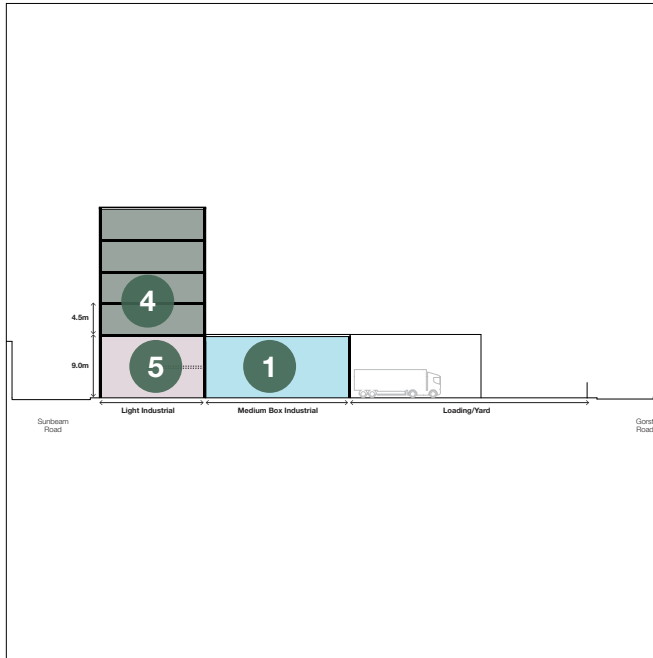

#### Approximate Existing Accommodation

B1a	300 m <sup>2</sup>	3,230 ft <sup>2</sup>
B2/B8	900 m <sup>2</sup>	9,700 ft <sup>2</sup>

#### Proposed Quantum of Development

B1a	2,398 m <sup>2</sup>	25,811 ft <sup>2</sup>
B1c	548 m <sup>2</sup>	5,898 ft <sup>2</sup>
B2/B8	1,542 m <sup>2</sup>	16,598 ft <sup>2</sup>

#### 1 Medium Industrial Units

Larger industrial uses located to north of site, where vehicular access from Park Royal Road is more direct.

#### 2 Loading

16.5m loading bays and service yard accessed via Gorst Road.

#### 3 Small Industrial Units

Units with loading from Sunbeam Road to south of site.

#### 4 B1 Units

Upper storeys support B1 uses with dedicated access off Sunbeam Road. Location of B1 uses takes advantage of most direct route to North Acton station.

#### 5 Mezzanine Level

Ceiling/eaves heights offer potential for internal subdivision of industrial units with mezzanine levels.

# C Case Studies

## C.2 Waxlow Road

### C.2.1 Site Selection

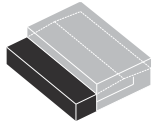

#### Horizontal Extension

**Address** 13 Waxlow Road  
**Postcode** NW10 7NU  
**PTAL** 3

**Boundary** Freehold  
**Business** Coach and bus hire  
**Site Type** Standalone warehouse  
**Building Type** Large industrial  
**Site Area** 2,937m<sup>2</sup>  
**Footprint** 812m<sup>2</sup>

#### Development Summary

Total Development Value (GDV)	£ 11m
Total Development Cost	£ 8.7m
Residual Land Value (RLV)	£ 2.5m
Estimated Land Cost (EUV)	£ 1.4m
Viable	Yes

#### Site History

Planning permission has been granted (15/5358) for a change of use of the coach depot site, which is currently Sui Generis into a use within the use classes B1c (light industry), B2 (general industry) or B8 (storage and distribution).

#### Site Selection

The site has been selected due to its low area efficiency. It is a good example of an older warehouse and yard along the canal that could be used more efficiently. There are a number of sites along the canal with similar characteristics.

#### Development Objectives

The existing function of the building is industry and storage (B8/B2). There is also an opportunity to add additional B1c and B1a to the site taking advantage of the canalside amenity.

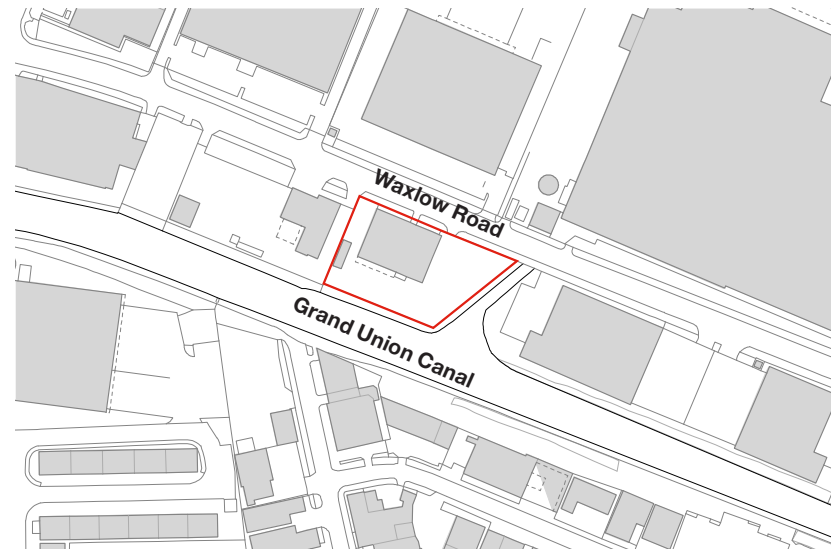
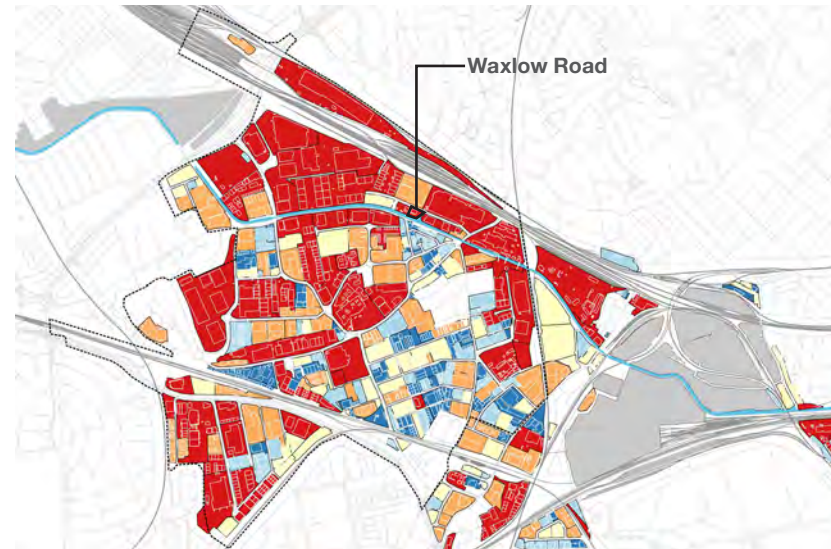

## C Case Studies

### C.2 Waxlow Road

#### C.2.2 Existing site



#### Waxlow Road and Canal

The site has the canal on two sides with the Grand Union on the south and a smaller inlet on the eastern boundary. Waxlow Road is located on the north side.



#### Waxlow Road looking west

The existing brick warehouse building with yard space in the foreground.

# C Case Studies

## C.2 Waxlow Road

### C.2.3 Mix and Space Requirements

#### Design Principle 1: Stack Uses



#### Design Principle 2: Shared Facilities

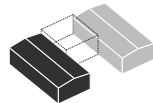

#### Design Principle 3: Separate Access

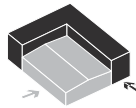

#### Design Principle 4: Exploit Location



#### Design Principle 6: Placemaking

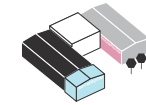

Use Class	Justification
B1a	PTAL and local amenity provide attractive location for B1 uses.
B1c	PTAL and separate access to Waxlow Road.
B2/B8	Continuation of existing site uses.

Typology	Justification
Small office	Separate entrance from Waxlow Road for pedestrians.
Studio/ workspace	With access to a dedicated loading area and yard space off Waxlow Road. Separate pedestrian entrance.
Small warehouse	Continuation of use of the existing building B2/B8.

#### Typology Requirements

For spatial/operational requirements for each typology, please refer to appendix E.

	Key Design Considerations
Place making	Street presence is improved with the addition of workspace and office on Waxlow Road. The design makes the most of the canal side location providing amenity along the canal edge.
Viability	Space with views over the canal (amenity space) and proximity to public transport (accessibility) means Waxlow Road is likely to prove attractive to B1a office occupiers, much more so than other case study sites. This is likely to result in better rental values and interest from investors, and overall the site being more viable to deliver office space, albeit with other value generating employment uses such as industrial
Employment Density	Multi-storey typologies offer the opportunity to create space for higher density use classes, whilst maintaining industrial space on the ground floor.

## C Case Studies

### C.2 Waxlow Road

#### C.2.4 Precedents



#### **Regent's Canal, London**

Office space fronting onto the canal.



#### **Woolwich, London**

Light industrial at ground level and offices/studios above.



#### **Hackney Wick, London**

Outdoor space making the most of the canal side amenity.

# C Case Studies

## C.2 Waxlow Road

### C.2.5 Schematic Design

**Summary**  
 The design delivers new office and workspace over looking the canal with added canal-side amenity space. Existing B2/B8 landuse is maintained and with an increase in overall development by 310%.

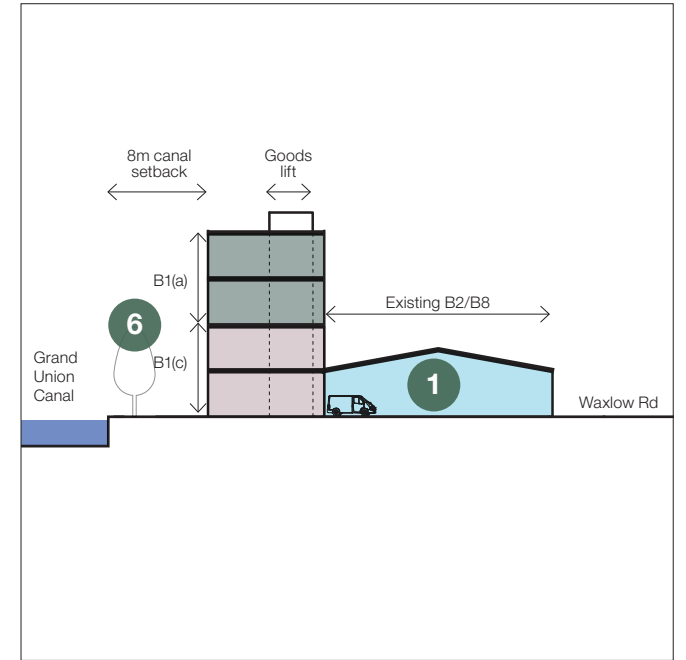
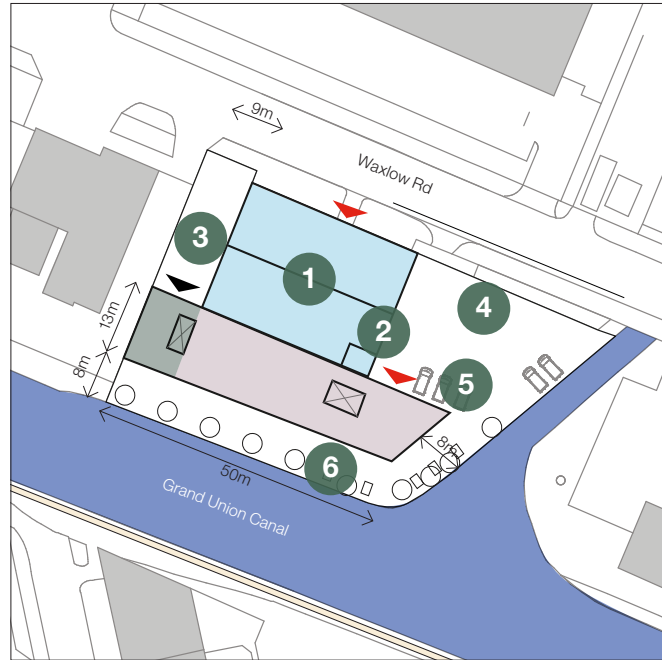
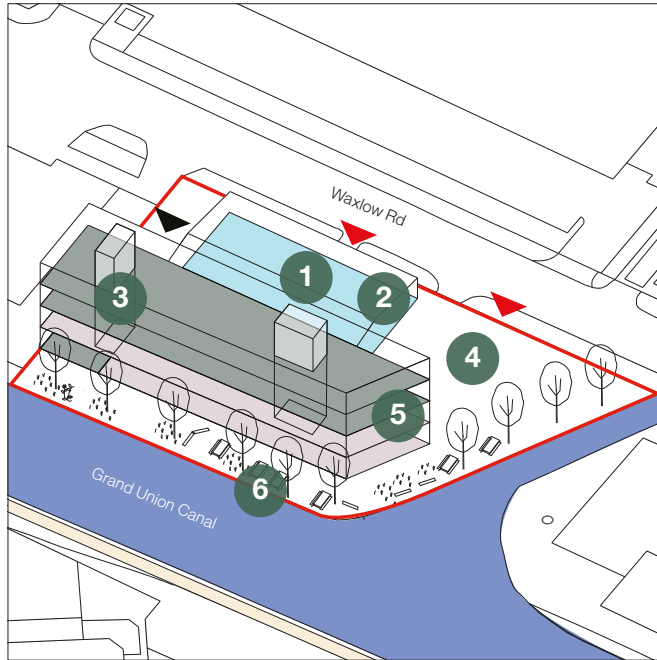
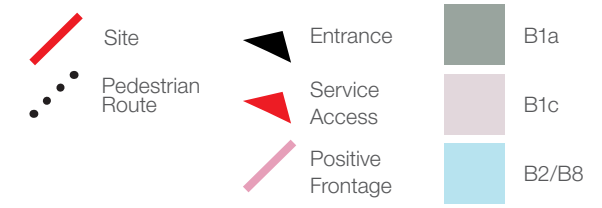

**Approximate Existing Accommodation**

812 m<sup>2</sup>      8,740 ft<sup>2</sup>

**Proposed Quantum of Development**

B1a	1,433 m <sup>2</sup>	15,425 ft <sup>2</sup>
B1c	1,191 m <sup>2</sup>	12,820 ft <sup>2</sup>
B2/B8	703 m <sup>2</sup>	7,567 ft <sup>2</sup>

- 1. Existing brick building**  
 The existing brick building is used for B2/B8 storage and also includes internal office and workspace B1c. Entry for vehicles from Waxlow Road.
- 2. Entry to existing building**  
 Entry to the existing building will be maintained.
- 3. Separate entrance for pedestrians to new B1a space**  
 Entry from Waxlow Road for pedestrians to reception area on ground floor. A lift connects the entrance foyer with the upper two B1a storeys.

- 4. Yard space**  
 Accessible from Waxlow Road.
- 5. Loading access and entrance for B1c**  
 Entry from Waxlow Road with access to yard and goods lift.
- 6. Canal setback**  
 All development has been setback 8 meters from the canal to allow access.

# C Case Studies

## C.3 North Acton Road

### C.3.1 Site Selection

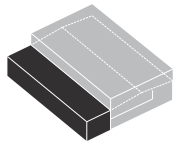

**Horizontal Extension**

**Address** 37-39 North Acton Road  
**Postcode** NW10 6PF  
**PTAL** 4

**Boundary** Freehold  
**Business** Packaging company  
**Site Type** Industrial Estate  
**Building Type** Large Industrial  
**Site Area** 5,945 m<sup>2</sup>  
**Footprint** 2,004 m<sup>2</sup>

#### Development Summary

Total Development Value (GDV)	£ 26.4m
Total Development Cost	£ 20.9m
Residual Land Value (RLV)	£ 5.5m
Estimated Land Cost (EUV)	£ 3m
Viable	Yes

#### Site History

Currently occupied by owner occupier using the site for wholesale.

No relevant planning history.

#### Site Selection

The site is identified as having a low area efficiency. The potential to intensify the site is further justified by its location and resultant PTAL which could support the addition of other uses.

#### Development Objectives

The sites location and proximity to Harlesden station and amenity space makes workspace on the site potentially desirable.

The existing building on North Acton Road has heritage quality and could therefore be attractive to come occupiers. Partial demolition and redevelopment could make the site coverage more efficient.

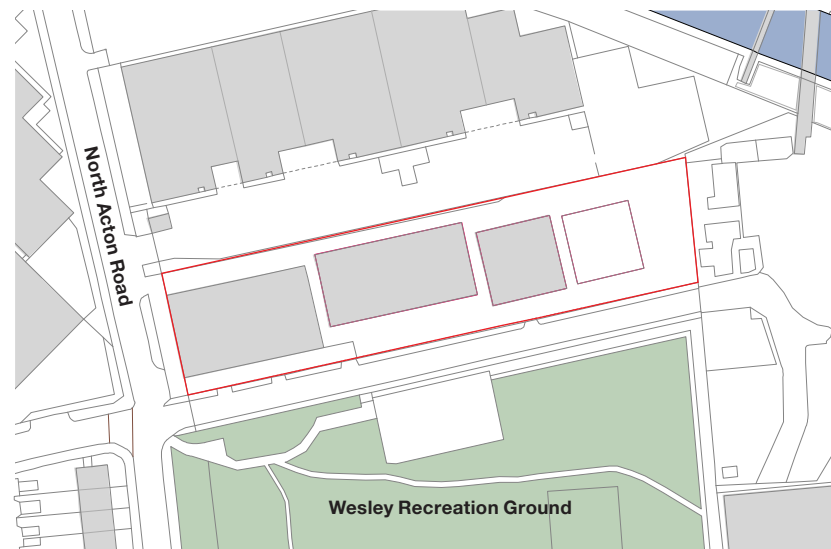
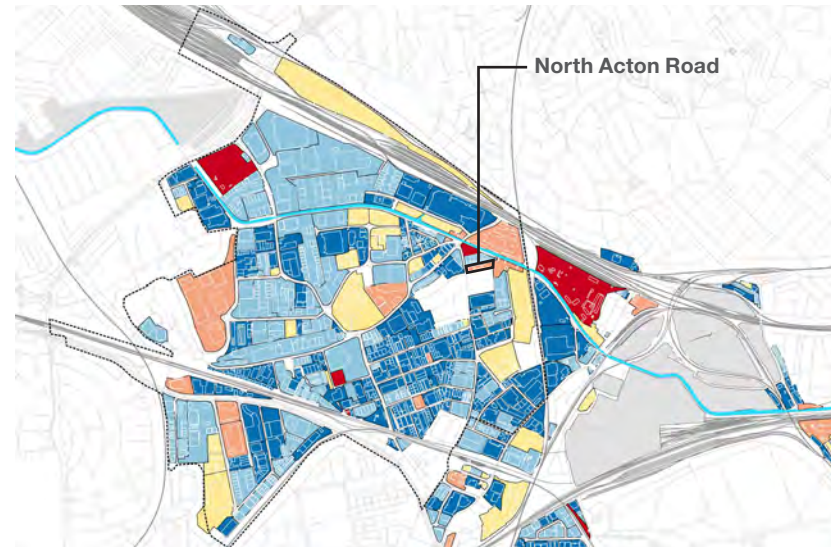

## C Case Studies

### C.3 North Acton Road

#### C.3.2 Existing Site



#### View to south

Existing warehouse on North Acton Road



#### Sunbeam Road

Access Road to south of site, along north edge of Wesley Recreation ground

# C Case Studies

## C.3 North Acton Road

### C.3.3 Mix and Space Requirements

**Design Principle 1:  
Separate Access**

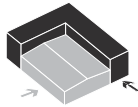

**Design Principle 2:  
Stack Uses**

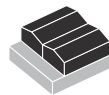

**Design Principle 4:  
Exploit Accessibility**

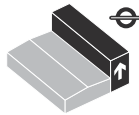

**Design Principle 6:  
Placemaking**

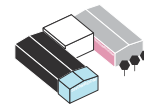

Use Class	Justification
B1a	PTAL and local open space amenity provide potential for attractive location for B1 uses.
B1c	Potential for additional workspace without loading/yard through horizontal extension or internal subdivision
B2/B8	Partial demolition would allow for provision of larger industrial units.

Typology	Justification
Small Warehouse	Access and size of site restricts larger industrial units, but size and proportions of plot can accommodate warehouses through partial demolition
Studio/ Workshop	Infill development could accommodate artisan manufacturing/ateliers.
Small Office	Infill development offers potential for entrances separate from industrial spaces

#### Typology Requirements

For spatial/operational requirements for each typology, please refer to Appendix E.

	Key Design Considerations
Place making	The existing assets of the existing warehouse on North Acton Lane and the Wesley Recreation ground should be exploited. A positive frontage should be created on the south and west boundaries of the site.
Viability	Values for B1a space in this location limit the extent of viable refurbishment to minor improvements and single storey horizontal extension. Key value drivers remains industrial as a good proportion of floor space.
Employment Density	Introducing higher employment densities at ground floor through B1c and provision of B1a space can exploit the location to provide an uplift in densities.

## C Case Studies

### C.3 North Acton Road

#### C.3.4 Precedents



#### **Brooklyn Navy Yards, Brooklyn**

Internal subdivision could incorporate higher grade industrial space in heritage building.



#### **Hôtel Industriel, in Bois-de-Bay, Satigny**

Small industrial units along with studio/workshop spaces.

# C Case Studies

## C.3 North Acton Road

### C.3.5 Schematic Design

**Summary**  
 The design delivers 320% increase of overall floorspace, creating a positive frontage onto North Acton Road and Wesley Recreation Ground, maximising amenity for workers.

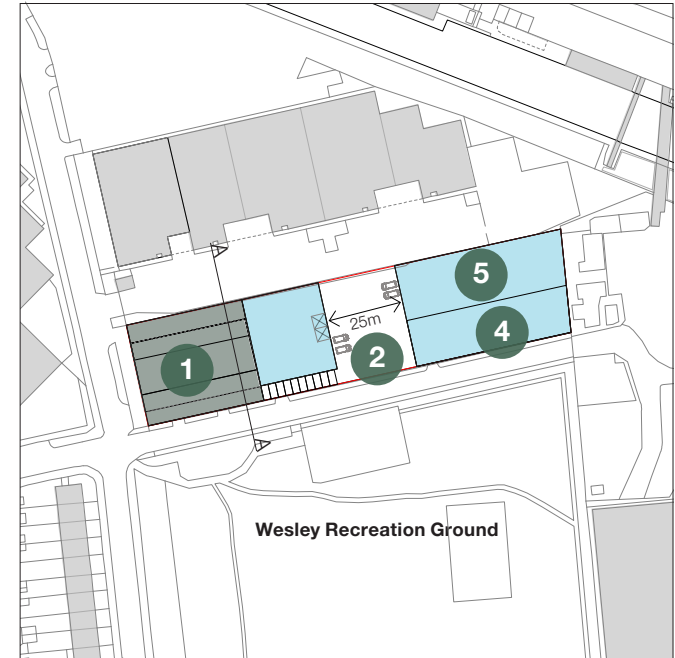
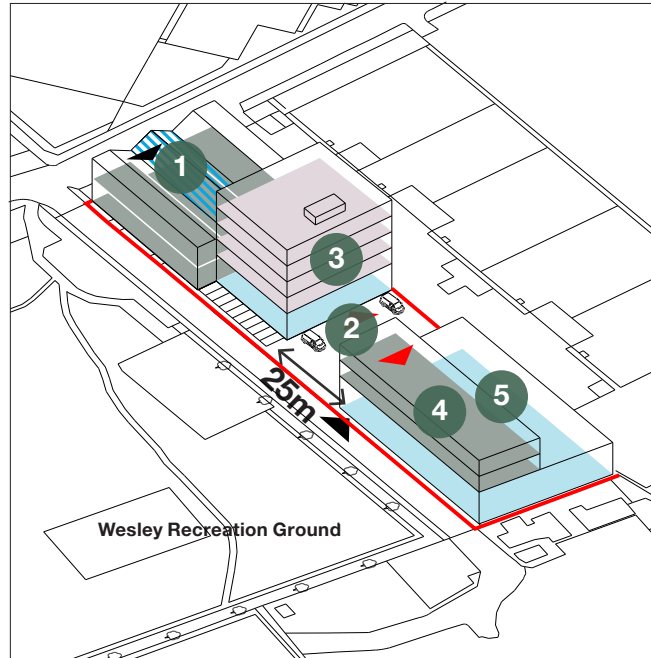
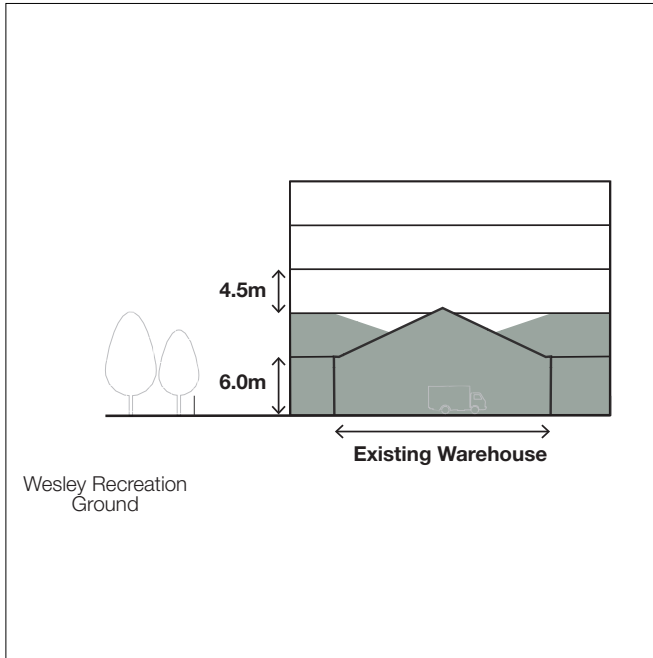
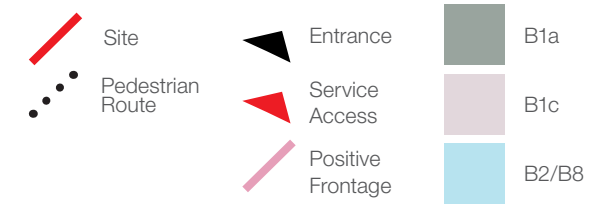

#### Approximate Existing Accommodation

2,004 m<sup>2</sup>      21,561 ft<sup>2</sup>

#### Proposed Quantum of Development

B1a      3,170 m<sup>2</sup>      34,121 ft<sup>2</sup>

B1c      2,812 m<sup>2</sup>      30,268 ft<sup>2</sup>

B2/B8      2,426 m<sup>2</sup>      26,113 ft<sup>2</sup>

#### 1 Retain Warehouse Building

Existing warehouse building retained and extended to north and south. Building refurbished and use changed to B1a.

#### 2 Create Shared Yard

Yard space services new B1a/c building and B2/B8 warehouse. Yard dimensioned to accommodate transit vehicles.

#### 3 Goods Lift

B1c spaces serviced via shared goods lift.

#### 4 Office Space

Office space exploits views over park to the south.

#### 5 B2/B8 unit

Medium sized industrial warehouse

# C Case Studies

## C.4 (7-11) Minerva Road

### C.4.1 Site Selection

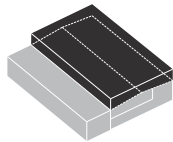

**Vertical Extension**

**Address** 7-11 Minerva Road  
**Postcode** NW10 6HJ  
**PTAL** 2

**Boundary** Site  
**Business** Multiple  
**Site Type** Business Centre  
**Building Type** Studio/Workshop  
**Site Area** 4,063 m<sup>2</sup>  
**Footprint** 2,500 m<sup>2</sup>

#### Development Summary

Total Development Value (GDV)	£ 19.6m
Total Development Cost	£ 15.5m
Residual Land Value (RLV)	£ 1.4m
Estimated Land Cost (EUV)	£ 4m
Viable	No

#### Site History

The Business Centres comprise of two buildings - the Alpha building, which houses the main reception and management office, office spaces, studios and the workshops. The Beta building is designed for light industrial businesses, food industry and cater units. Previous planning application in 2002 for 4 storeys refused.

#### Site Selection

The site is identified as having a low FAR. Given the location of the site it is considered that vertical extension could provide increase in employment space within the existing building footprint and without compromising the yard spaces that currently exist.

#### Development Objectives

Access to the site from two roads offers flexibility in how intensification can be implemented. The location within Park Royal is appropriate for increased employment densities due to its proximity to public transport and amenity.

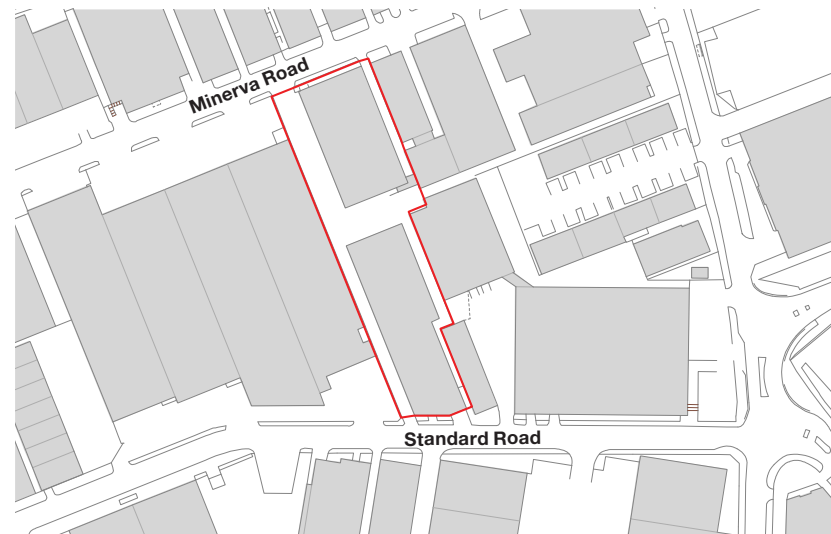
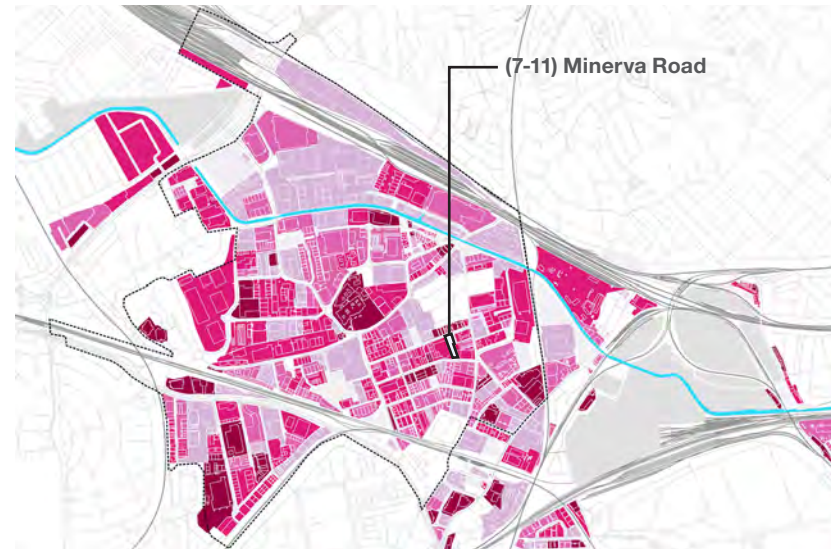

## C Case Studies

C.4 (7-11) Minerva Road

C.4.2 Existing Site



### Minerva Road

Existing two storey building on Minerva Road



### Existing

Access Road to south of site, along north edge of Wesley Recreation ground

# C Case Studies

## C.4 (7-11) Minerva Road

### C.4.3 Mix and Space Requirements

**Design Principle 1:  
Separate Access**

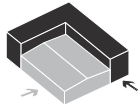

**Design Principle 2:  
Stack Uses**

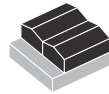

Use Class	Justification
B1a	Existing uses on site compatible with increased provision of B1a uses
B1c	Where access is appropriate light industrial uses can be incorporated

Typology	Justification
Studio/ Workshop	Where access allows extension can accommodate artisan manufacturing/ateliers.
Small Office	New provision can exploit existing facilities/management

#### Typology Requirements

For spatial/operational requirements for each typology, please refer to appendix E.

	Key Design Considerations
Place making	Servicing the buildings from a yard in the centre of the block would allow positive frontages onto Standard Road and Minerva Road.
Viability	Vertical extension limited to single storey lightweight construction, ensuring costs in alterations to existing building are kept to circa 60% of new build costs. Likely to be more cost effective to demolish building fronting Standard Road rather than retain and refurbish.
Employment Density	Extending the existing business centre creates more floor space in a high density employment site.

## C Case Studies

C.4 (7-11) Minerva Road

C.4.4 Mix and Space Requirements



### Vertical Extension (Bermondsey, London)

Vertical extension to brick building providing flexible workspace.



### Positive Frontage (Laserfactory, Farmington)

Entrances on the street and allowing the building to form the boundary of the site create a positive frontage.

# C Case Studies

## C.4 (7-11) Minerva Road

### C.4.5 Schematic Design

**Summary**  
**The design delivers 122% increase of overall floorspace, creating a positive frontage onto Minerva Road and Standard Road.**

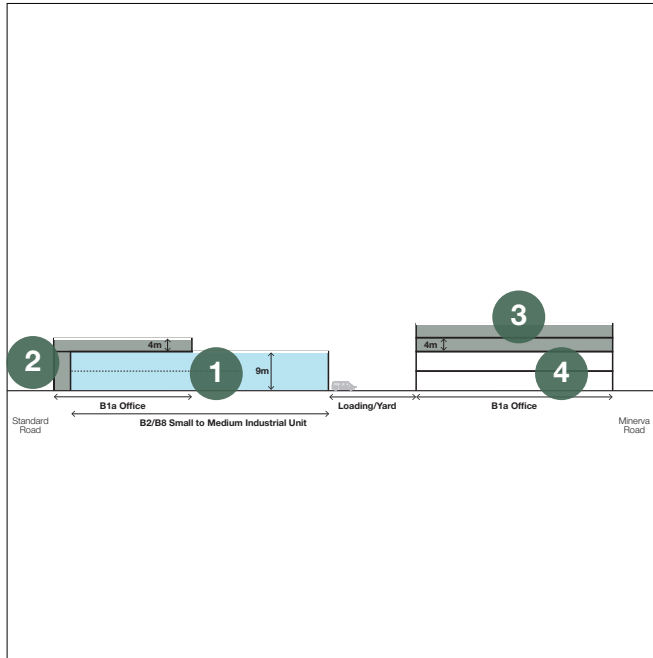
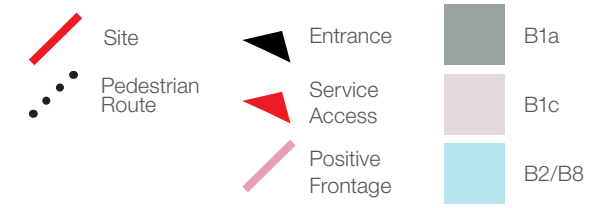

**Approximate Existing Accommodation**

2,749 m<sup>2</sup>      29,589 sqft

**Quantum of Development**

Retained	2,202 m <sup>2</sup>	23,702 sqft
B1a	2,764 m <sup>2</sup>	29,751 sqft
B2/B8	1,155 m <sup>2</sup>	12,430 sqft

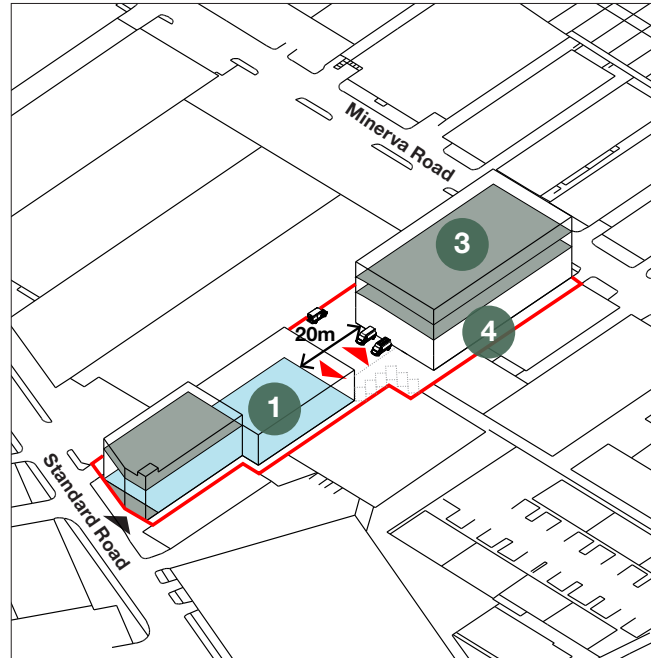

**1 Small to Medium Industrial Unit**

Industrial unit with service yard to rear, allowing building to form boundary of site on Standard Road

**2 Frontage**

Entrance to B1a space on Standard Road, providing positive frontage onto Standard Road

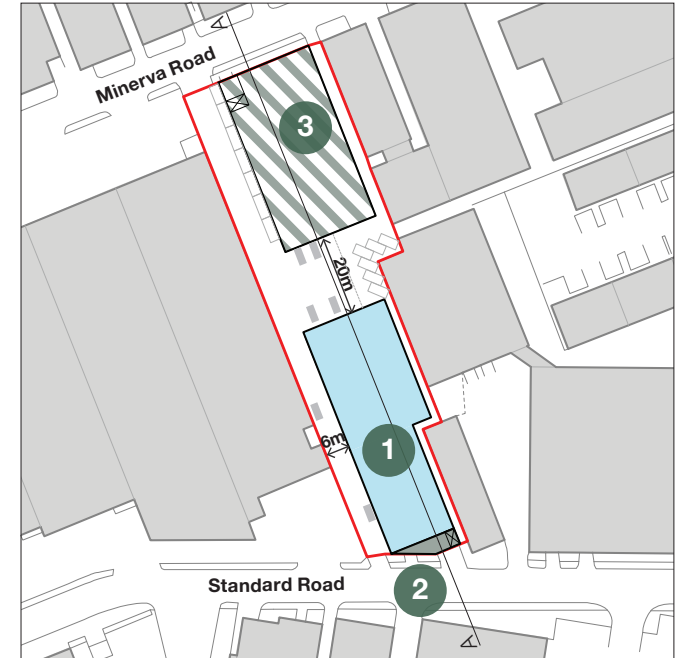

**3 Two storey extension**

Lightweight two storey extension added to northern block (7-11) Minerva Road.

**4 Retained space**

Existing two storey brick building to north of site retained for existing use.

# C Case Studies

## C.5 Origin Business Park

### C.5.1 Site Selection

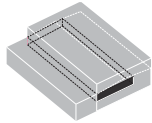

#### Internal Subdivision

<b>Address</b>	Unit 2, Rainsford Rd
<b>Postcode</b>	NW10 7FW
<b>PTAL</b>	1b
<b>Boundary</b>	Freehold
<b>Business</b>	-
<b>Site Type</b>	Large Industrial
<b>Building Type</b>	Stand alone warehouse
<b>Site Area</b>	6,190m <sup>2</sup>
<b>Footprint</b>	3,033m <sup>2</sup>

#### Development Summary

Total Development Value (GDV)	£ 17.2m
Total Development Cost	£ 13.6m
Residual Land Value (RLV)	£ 8m
Estimated Land Cost (EUV)	£ 8.7m
Viable	No

#### Site History

The warehouse was built in part of the Origin Business Park by Segro as speculative development and has been vacant since its construction in 2014.

#### Site Selection

This modern warehouse is representative of the large industrial units being developed in the west of Park Royal. There is potential for intensification of the building through internal subdivision with the warehouse having 12m clear height. This site is a 15 minute walk from Park Royal underground station and also offers the opportunity to diversify the mix of uses within the Origin Business Park.

#### Development Objectives

Located in the Origin Business Park it has good access to major London roads as well as access for HGVs and loading facilities. The business park already has a number of food manufacturing and logistics companies.

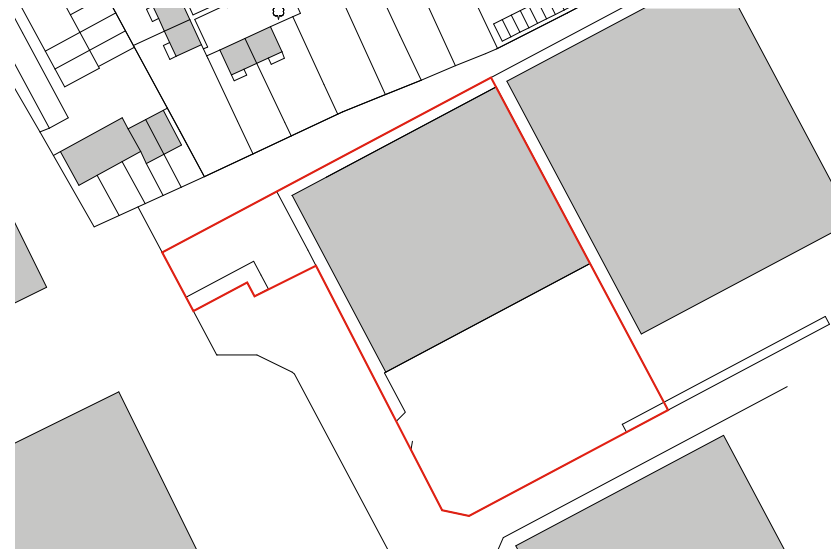
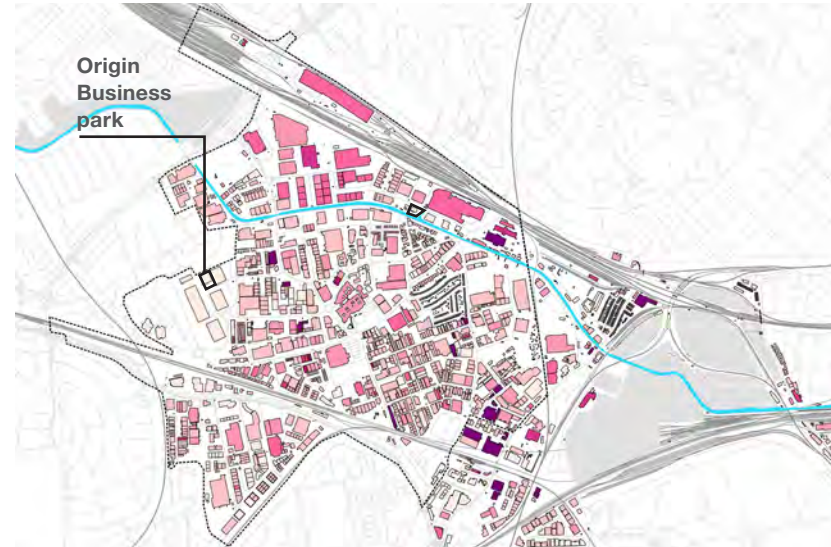

## C Case Studies

### C.5 Origin Business Park

#### C.5.1 Existing site



#### View from street

The existing building with the warehouse and loading doors and yard on the right.



#### Warehouse interior

Interior of the warehouse looking toward the loading doors.

# C Case Studies

## C.5 Origin Business Park

### C.5.2 Mix and Space Requirements

**Design Principle 1:  
Separate Access**

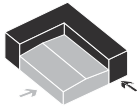

**Design Principle 2:  
Stack Uses**

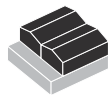

**Design Principle 3:  
Shared Facilities**

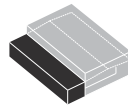

**Design Principle 4:  
Exploit Location**

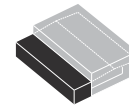

Use Class	Justification
B1(a)	Location close to the Park Royal Station as well as other office buildings such as First Central.
B1(c)	Flexible internal design allows for a range in the size of units.

Typology	Justification
Small office space	Flexible space and cluster of activity.
Studio workshop	Access to large yard space.

#### Typology Requirements

For spatial/operational requirements for each typology, please refer to appendix E.

	Key Design Considerations
Place making	The addition of new functions, internal break out spaces as well as the outdoor workspace/terrace area.
Viability	The existing industrial building on the site is of high (Grade A) quality and recently built. As such the densification of workspace should focus on B1a office uses, and the quantum of floorspace should provide a significant uplift on the site within the existing building envelope.
Employment Density	The change of use from B2/B8 to B1 uses can provide a significant density of workspace within the existing building envelope.

## C Case Studies

### C.5 Origin Business Park

#### C.5.3 Precedents



#### Temporary structures, Madrid

The Red Bull Music Academy in Madrid involved the construction of a series of freestanding structures in an existing warehouse with studios, offices, a lounge and lecture hall.



#### Free standing structures, Delft

Workspace comprising of offices, workshops and break out spaces for start up companies in a larger 60x70m warehouse in Delft.



#### Mix of functions, London

Here East is the transformation of the former Olympic broadcast centre into 1.2 million sqft of floorspace for creative and digital industries.

# C Case Studies

## C.5 Origin Business Park

### C.5.3 Schematic Design

**Summary**  
 The design brings new workspace, office and studio space into the area and provides adjacent outside amenity. It has the potential to demonstrate a new approach to the intensification of large warehouse sites.

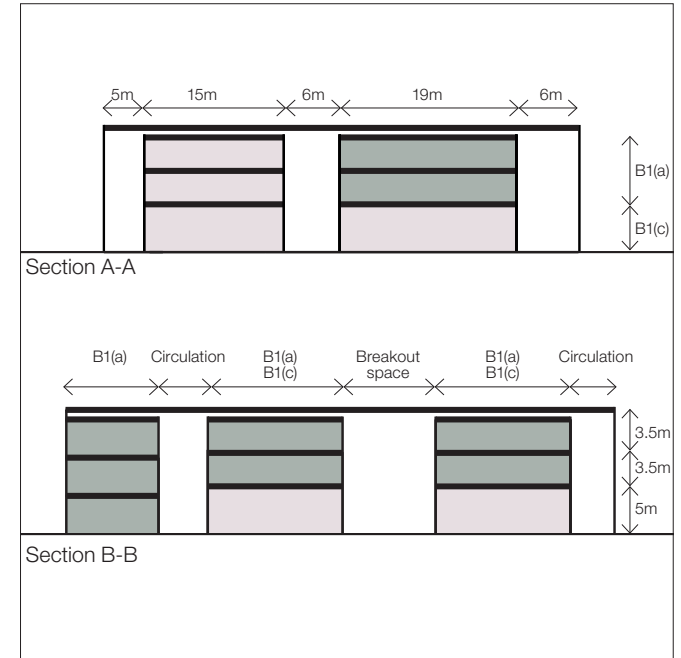
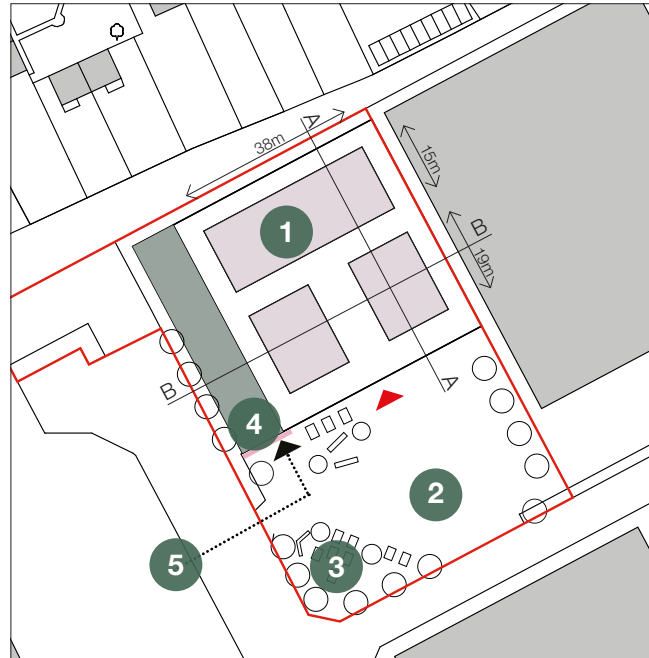
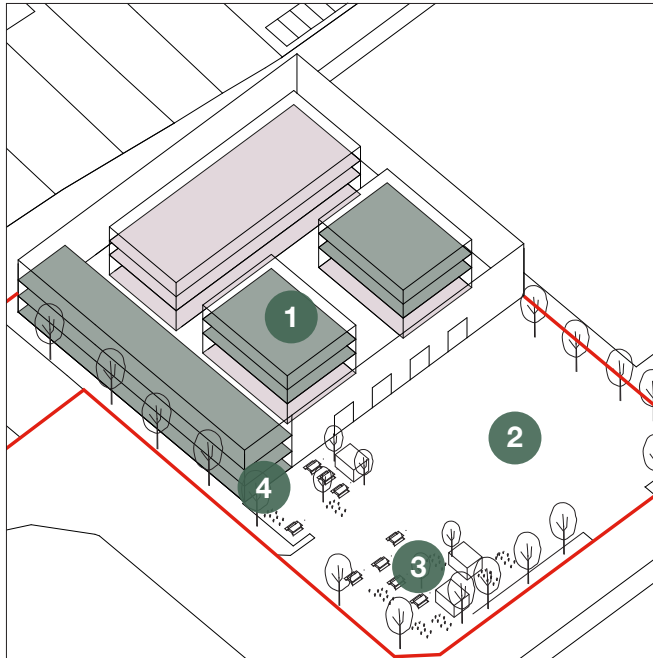
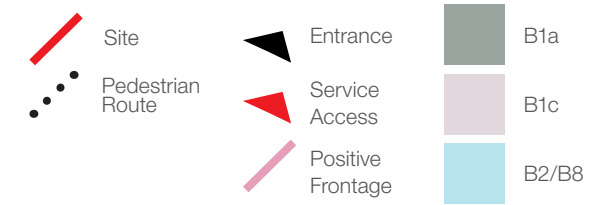

**Approximate Existing Accommodation**

3,033 m<sup>2</sup>      32,646 ft<sup>2</sup>

**Proposed Quantum of Development**

B1a	2,621 m <sup>2</sup>	28,212 ft <sup>2</sup>
B1c	2,302 m <sup>2</sup>	24,778 ft <sup>2</sup>

**1. Workspace**

Area with a mix of workspace and studios surrounded by communal spaces.

**2. Yard**

Vehicle access to the loading yard from Victoria Road is maintained. There is enough clearance for HGVs.

**3. Courtyard/terrace**

Informal outside area with seating.

**4. Entrance**

Improvements to the facade are proposed to make the entrance legible and assist way finding and placemaking.

**5. New link to Park Royal tube**

Viability would be improved if new pedestrian route to Park Royal station was created through the Origin Estate to Lakeside Drive and First Central.

## C Case Studies

### C.6 Site Identification Criteria

Site Type	Reference Case Study	Spatial Indicators	Incentives
A	Willen Field Road	Site Area, Site Proportion	
B	Gorst Road	Site Area, Site Proportion	
C	Waxlow Road	Site Area, Site Proportion	Area Efficiency
D	North Acton Road	Site Area, Site Proportion	Buildings per Freehold
E	97 Victoria Road	Site Area, Site Proportion, FAR	
F	40-54A Minerva Road	Site Area, Site Proportion	Plot Ratio
G	7-11 Minerva Road	Site Area, Height	Buildings per Freehold
H	Bashley Road	Site Area, Site Proportion	
I	Origin Business Park	Building Footprint, Building Height	

# Appendix D

## Accommodation Schedule

# D Accomodation Schedule

## D.1 Intensification Sites

Case Study Type	Site Wide Employment Area										
	Place	Current Employment	Total area	Total Area (ha)	Low (m2)			High (m2)			
					B1a	B1c	B2/B8	B1a	B1c	B2/B8	
Willan Field Road	OP01	48	6,542	0.654	n/a				2,773	507	2,773
	OP02	67	6,088	0.609					2,581	472	2,581
	PC01	0	0	0.000					0	0	0
	PR01	123	12,414	1.241					5,263	963	11,777
	PR02	495	36,853	3.685					15,624	2,858	34,962
PR03	125	6,778	0.678	2,874	526	6,431					
PR04	0	0	0.000	0	0	0					
Gorst Road	OP01	25	4,576	0.458	764	1,208	3,188	2,852	652	1,834	
	OP02	59	4,993	0.499	833	1,319	3,478	3,112	711	2,001	
	PC01	0	0	0.000	0	0	0	0	0	0	
	PR01	222	9,061	0.906	1,512	2,393	6,312	5,648	1,291	3,632	
	PR02	177	13,676	1.368	2,282	3,612	9,527	8,525	1,948	5,482	
PR03	0	0	0.000	0	0	0	0	0	0		
PR04	74	4,840	0.484	808	1,278	3,372	3,017	689	1,940		
Wadlow Road	OP01	0	0	0.000	0	0	0	0	0	0	
	OP02	0	0	0.000	0	0	0	0	0	0	
	PC01	0	0	0.000	0	0	0	0	0	0	
	PR01	0	0	0.000	0	0	0	0	0	0	
	PR02	18	2984.87	0.298	979	1,815	714	1,456	355	714	
PR03	0	0	0.000	0	0	0	0	0	0		
PR04	0	0	0.000	0	0	0	0	0	0		
Brookes Packaging	OP01	0	0	0.000	0	0	0	0	0	0	
	OP02	0	0	0.000	0	0	0	0	0	0	
	PC01	0	0	0.000	0	0	0	0	0	0	
	PR01	0	0	0.000	0	0	0	0	0	0	
	PR02	9	4,767	0.477	2,769	3,292	2,547	3,170	2,812	2,426	
PR03	71	4,437	0.444	2,577	3,064	2,370	2,950	2,617	2,258		
PR04	0	0	0.000	0	0	0	0	0	0		
Victoria Road	OP01	0	0	0.000	n/a			0	0	0	
	OP02	96	7,437	0.744				5,541	8,645	3,500	
	PC01	0	0	0.000				0	0	0	
	PR01	0	0	0.000				0	0	0	
	PR02	34	3,779	0.378				2,816	4,393	1,778	
PR03	0	0	0.000	0	0	0					
PR04	0	0	0.000	0	0	0					
Minerva Road	OP01	31	7867.81	0.787	n/a			4,578	6,413	2,754	
	OP02	0	0	0.000				0	0	0	
	PC01	0	0	0.000				0	0	0	
	PR01	0	0	0.000				0	0	0	
	PR02	0	0	0.000				0	0	0	
PR03	0	0	0.000	0	0	0					
PR04	0	0	0.000	0	0	0					
Alpha Beta Centre	OP01	113	9466.59	0.947	n/a			16,277	0	1,095	
	OP02	0	0	0.000				0	0	0	
	PC01	0	0	0.000				0	0	0	
	PR01	0	0	0.000				0	0	0	
	PR02	0	0	0.000				0	0	0	
PR03	102	6220.13	0.622	10,695	0	719					
PR04	0	0	0.000	0	0	0					
Bashley Road	OP01	365	19912.5	1.991	n/a			1,506	682	19,512	
	OP02	0	0	0.000				0	0	0	
	PC01	0	0	0.000				0	0	0	
	PR01	161	21799.18	2.180				1,648	747	21,361	
	PR02	814	41938.46	4.194				3,171	1,437	41,095	
PR03	0	0	0.000	0	0	0					
PR04	149	20662.12	2.066	1,562	708	20,247					
Origin Business Park	OP01	0	0	0.000	n/a			0	0	0	
	OP02	0	0	0.000				0	0	0	
	PC01	0	0	0.000				0	0	0	
	PR01	0	2,923	2923.000				2,526	2,218	1,315	
	PR02	132	6,599	6599.000				5,703	5,006	2,970	
PR03	48	2,225	2225.000	1,923	1,688	1,001					
PR04	0	0	0.000	0	0	0					

\*Total GIA

# Appendix E

## Typological Design Considerations

# E Typological Design Considerations

## D.1 Intensification Sites

Use	Sectors	Use Class	Ceiling Height	Floor	Floor Loads	Loading Bay
B1a: Office (small < 5,000 sq ft)	Professional and business services / Creative Industries	B1	2.9m - 4.4m	Any	2.5-4kN/m2	n/a
B1a: Office (Medium-Large > 5,000 sq ft)	Professional and business services / Corporate Businesses / Creative Industries / Social Enterprises / Start-Ups and early-stage enterprises	B1	2.9m - 4.4m	Any	2.5-4kN/m2	n/a
B1c: Light Industry / Work Shop (without loading bay and yard)	Creative Industries / Creative Services	B1b, B1c	3.5m (2.9m - 4.4m)	Any	5kN/m2	Occasional Use >4m
B2/B8/B1c: Industrial (small <5,000 sq ft)	Small scale making and light manufacturing / Secondary-Tertiary industry / Small-Medium food & drink manufacturing / Industrial Crafts and Small Scale Manufacturing / Open access specialist fabrication	B2, B8	4.5m - 9.0m	Ground floor preferred	>10kN/m2	>4m
B2/B8/B1c: Industrial (small to medium 5,000-10,000 sq ft)	Large scale making and light manufacturing / Secondary-Tertiary industry / Medium-Large food & drink manufacturing / Large scale storage providers	B2, B8	4.5m - 9.0m	Ground floor preferred	>10kN/m2	30-40m
B2/B8/B1c: Industrial (medium 10,000-50,000 sq ft)		B2, B8	4.5m - 9.0m	Ground floor preferred	>10kN/m2	30-40m
B2/B8/B1c: Industrial (large 50,000-100,000 sq ft)		B2, B8	4.5m - 9.0m	Ground floor preferred	>10kN/m2	30-40m

### Source

LLDC Employment Space Study, 2015 We Made That and Aecom

# Appendix F

## Case Study Viability Appraisal Assumptions

# F Case Study Viability Appraisal Assumptions

## F.1 Costs and Values

### F.1.1 Rents

#### Rents

The Table opposite summarises the rents used for the calculation of Existing Use Value.

Use	Low (Tertiary) Rents (£ psf)	Medium (Secondary) Rents (£ psf)	Comments
B1a: Office (small < 5,000 sq ft)	£12.50	£15.00	Offices in this size bracket usually pay higher rents than the next size bracket. Rent determined by attractiveness of location, proximity to public transport and amenities and incentives package.
B1a: Office (Medium-Large > 5,000 sq ft)	£12.50	£15.00	As above but rents tend to be lower due to tenants taking larger floorspace.
B1c: Light Industry / Work Shop (without loading bay and yard)	£8.50	£13.00	This type of accommodation tends to only be found with older tertiary stock and does not meet the requirements of modern occupiers therefore rents tend to be lower. That said this accommodation tends to work for smaller businesses for whom it is more affordable.
B2/B8/B1c: Industrial (small <3,000 sq ft)	£12.00	£17.00	Demand is good for smaller units and units in this size bracket always pay a higher rent.
B2/B8/B1c: Industrial (small to medium 3,000-10,000 sq ft)	£10.00	£15.00	Size range where demand is highest therefore rents high.
B2/B8/B1c: Industrial (medium 10,000-50,000 sq ft)	£9.00	£14.00	Size range where demand is highest therefore rents high.
B2/B8/B1c: Industrial (large 50,000-100,000 sq ft)	£9.00	£13.00	Demand present for largest units however economies of scale from size usually means occupiers pay slightly less than units in smaller size brackets.
Open storage / car parking	n/a	n/a	Redevelopment opportunity. Scarce availability in Park Royal.

# F Case Study Viability Appraisal Assumptions

## F.1 Costs and Values

### F.1.1 Rents

#### New and Refurbished Space

Use	Refurbished Space Rents (£ psf)	New Space (Grade A) Rents (£ psf)	Use	Refurbished Space Rents (£ psf)	New Space (Grade A) Rents (£ psf)
A1 / A3: Shops / Cafes- Restaurants	£15.00	£20.00	B2/B8/B1c: Industrial (medium 10,000-50,000 sq ft)	£14.00	£15.00
B1a: Office (small < 5,000 sq ft)	£15.00	£20.00	B2/B8/B1c: Industrial (large 50,000-100,000 sq ft)	£14.00	£15.00
B1a: Office (Medium-Large > 5,000 sq ft)	£16.00	£22.50	Open storage / car parking	n/a	n/a
B1b: Research and Development	£15.00	£20.00			
B1c: Light Industry / Work Shop (without loading bay and yard)	£14.00	£16.00			
B2/B8/B1c: Industrial (small <3,000 sq ft) with yard	£17.00	£20.00			
B2/B8/B1c: Industrial (small to medium 3,000-10,000 sq ft)	15.00	£17.00			

# F Case Study Viability Appraisal Assumptions

## F.1 Costs and Values

### F.1.2 Yields

#### Yields

The Table opposite summarises the yields used for the calculation of Existing Use Value.

Use	Low (Tertiary) Yields (%)	Medium (Secondary) Yields (%)	Comments
B1a: Office (small < 5,000 sq ft)	7.50%	6.75%	Generally units that do not meet investment standards will be harder to let for a good rent, going to tenants of a lower covenant strength, resulting in a higher yield.
B1a: Office (Medium-Large > 5,000 sq ft)	7.00%	6.50%	Larger floor plate / unit sizes are more attractive to investors though ultimate end yield dependent on quality of tenant.
B1c: Light Industry / Work Shop (without loading bay and yard)	7.50%	6.50%	Generally units that do not meet investment standards will be harder to let for a good rent, going to tenants of a lower covenant strength, resulting in a higher yield.
B2/B8/B1c: Industrial (small <5,000 sq ft)	6.50%	5.50%	Higher yields due to generally lower quality of tenant covenant financial covenant, higher management requirements and smaller revenue stream per unit achievable.
B2/B8/B1c: Industrial (small to medium 5,000-10,000 sq ft)	6.00%	5.25%	Lower yields due to higher value of lots size (floorspace) and resulting revenue stream. Often bought as part of or added to an investment portfolio. Yield depends on quality of tenant covenant/ financial strength.
B2/B8/B1c: Industrial (medium 10,000-50,000 sq ft)	6.00%	5.00%	As Above.
B2/B8/B1c: Industrial (large 50,000-100,000 sq ft)	5.75%	4.75%	As Above.
Open storage / car parking		£3m per acre	Values paid for sites are often above £3m, often equating to higher than potential investment value and will depend on desire by buyer to secure site. Owner occupiers often pay more to secure their own site.

# F Case Study Viability Appraisal Assumptions

## F.1 Costs and Values

### F.1.2 Yields

#### New and Refurbished Space

Use	Refurbished Space Rents (£ psf)	New Space (Grade A) Rents (£ psf)	Use	Refurbished Space Rents (£ psf)	New Space (Grade A) Rents (£ psf)
A1 / A3: Shops / Cafes- Restaurants	6.75%	6.25%	B2/B8/B1c: Industrial (medium 10,000-50,000 sq ft)	5.00%	4.50%
B1a: Office (small < 5,000 sq ft)	5.75%	5.5%	B2/B8/B1c: Industrial (large 50,000-100,000 sq ft)	4.75%	4.50%
B1a: Office (Medium-Large > 5,000 sq ft)	6.00%	5.25%	Open storage / car parking	n/a	n/a
B1b: Research and Development	6.50%	5.50%			
B1c: Light Industry / Work Shop (without loading bay and yard)	6.50%	6.00%			
B2/B8/B1c: Industrial (small <5,000 sq ft) with yard	5.50%	5.25%			
B2/B8/B1c: Industrial (small to medium 5,000-10,000 sq ft)	5.25%	4.75%			

# F Case Study Viability Appraisal Assumptions

## F.1 Costs and Values

### F.1.3 Development Assumptions

#### Development Assumptions

#### Commercial Use Value Assumptions

The development assumptions for the study schemes have been split into rental and investment yield assumptions for the proposed commercial development by use. The appropriate rents and yields have then been input into the model based on:

- Use
- Size

Table 5 sets out the value inputs utilised within the development appraisals to calculate the residual land value (RLV). These value inputs are based on our market research and discussions with C&W agents.

Rental and yield values have been applied to new space for each use based on (i) the anticipated size of development proposals; and (ii) value bands which the market utilises to differentiate between sizes as a result of specific assumptions. For example, it is assumed that larger space is more cost efficient to build and tenants would expect a slight discount to the rent to reflect fact more space taken. In respect of yields, assuming a good quality tenant and a minimum 5 year term, larger commercial units are generally more

attractive to investors and this is reflected in a slightly lower yield.

In applying specific values to a given building elements we have sought to only account for the rents and yields that we think are achievable on a planning use basis – i.e. B1a office and B1c workshop – rather than specific types of occupiers or growth sectors that each site may accommodate. We consider this the right level of detail for this exercise. Secondly, in the round all occupiers and investors would be expected to pay the prevailing market rate at the time. These are set out in section F.1.1.

Some sites contain more than one use which have different yield assumptions. For the purpose of this exercise we have assumed that each use is a standalone asset which can be sold individually rather as a whole site.

We have assumed that these will be ultimately owned by institutions/property companies who will rent to end occupiers/tenants.

# F Case Study Viability Appraisal Assumptions

## F.1 Costs and Values

### F.1.4 Cost Assumptions

#### Construction Costs

Detailed construction costs have been supplied by C&W's cost consultancy team and have been provided on a total cost basis (as opposed to rates per sq m / sq ft) for financial modelling exercise. Estimated construction costs for each study site are set out on page 92.

Construction costs include:

- Contractor's overheads and profit (OHP)
- Prelims
- Construction contingency
- Category A (Cat A) fit out standard which includes:
  1. Raised floors and suspended ceilings
  2. Basic mechanical and electrical services
  3. Fire detection and protection services
  4. Basic finishes to Cat A

Fit out costs to generally take buildings to Cat B standard are anticipated, in the round, to be covered by the rent free period that will be offered to each new tenant.

#### Other Development Cost

#### Assumptions

##### Site Servicing Costs

Key external and enabling infrastructure costs included (based on 5% of construction costs):

- Offsite drainage and utilities
- Offsite highways infrastructure
- Internal roads
- Landscaping

##### Community Infrastructure Levy (CIL)

OPDC charging rates are from the Preliminary Draft Charging Schedule (CIL rates not yet confirmed or chargeable)

Borough and Mayoral CIL have been charged separately against all applicable uses with their respective charges against the net additional floorspace on a GIA basis.

The site lies 50:50 within two London Boroughs, Brent and Ealing. However the entire study area is within OPDC boundary charging zone. We have utilised the following OPDC CIL charging rates.

OPDC Charging Zone:

- Office: £70 psm / £6.50 psf
- Industrial: £ nil

Mayoral CIL:

- Zone 2 for London Borough Brent/ Ealing is £35 psm against all uses except health, school and education.

To calculate applicable CIL for study sites with existing buildings, we have utilised the estimated existing building footprint (as indicated in Table 4) to calculate the existing gross internal area (GIA) then adjusted we have made to the proposed floor areas to calculate CIL.

#### Other Development Costs

- All professional fees have been allocated at 10% on construction costs which we consider to be industry standard for development and exercises of this nature.
- Development contingency has been input at 5% to reflect the high level nature of the appraisal and any uncertainty of potential issues with the site having undertaken no due diligence. Additional contingency has been factored into the build cost assumptions.
- Planning fees have been entered at £100,000 per site.
- Normal purchaser's costs have not been applied for acquisition and

disposal. This is on the assumption that an owner occupier already owns the land therefore is not incurring acquisition costs to realise the development

- Normal disposal cost have been applied as follows:

1. Purchasers Costs: 5%
2. Sales Agent Fees: 1%
3. Sales Legal Fees: 0.5%
4. Letting Agent Fees: 10%
5. Letting Legal Fees: 5%

#### Marketing

We have not made an allowance for marketing of the sites on sale, as for commercial building investment sales we consider this cost to be minimal.

#### Rent Free Periods and Letting Voids

We have applied a 9 month period to account for rent free and letting void periods assuming a minimum 5 year lease term.

# F Case Study Viability Appraisal Assumptions

## F.1 Costs and Values

### F.1.4 Cost Assumptions

#### Developer Profit

Developer's profit has been input at 20% profit on cost to reflect our assessment of development risk for the proposed development.

#### Demolition

Whilst recognising that costs can vary with different types of building, for clear sites we have applied £ nil demolition costs, however for sites with existing floor space we have applied an indicative rate of £40 per cubic sq m / £3.70 for demolition.

#### Finance Assumptions

We have applied a finance rate of 6.5% to all costs incurred delivering the proposed modelled developments.

#### Phasing and Delivery Timescales

##### Timing Assumptions

For a given site the timing assumption for each site falls within a fixed timescale category as set out in the Table 5 below. The purpose of accounting for time in the financial model is to take account of when finance costs will be incurred at points where costs outpace income.

In reality is of course that timing would be more specific for a detailed assessment of an individual site, but for this high level

assessment and in order to account for the scale of development proposed C&W feel this approach is appropriate across all study sites.

- Land purchase is assumed to be fixed within the first month of the cashflow on all sites – this is the point at which the residual land value generated by each site is 'paid' and therefore realised as a cost.
- Sales and construction cost is modelled on a straight line basis.

The table below outlines the adopted timing assumptions within the development appraisal financial model. It is assumed that planning and all associated consents are in place.

Development Stage	Duration (Months)
Site Purchase	0
Pre-Construction	6
Construction	12
Letting	6
Sale	1

#### Site Specific Phasing Assumptions

The Minerva Road site has been split into two phases, Phase 1 and Phase 2. We have assumed different start dates for each phase, whereby construction of Phase 2 commences upon the sale of Phase 1. However, all other timescales for each phase, in relation to pre-construction, construction, post-development, letting and sales are the same and as per Table 4.

#### Space Assumptions

We have made the following space assumptions when estimating floor areas with Hawkins \ Brown:

- B1c workshop net lettable space (or NIA) is 90% of GIA.
- Industrial B2 / B8 space is assumed have the same NIA as GIA in line with market approach, across all sites.
- Office gross to net conversion ranges between 80% - 90% and has been done on a measured basis as opposed to a blanket % assumption across all site.

# F Case Study Viability Appraisal Assumptions

## F.1 Costs and Values

### F.1.5 Construction Costs

#### Construction Costs - New Build

B1a Office	£171 psf *
B1c Workshop	£100-£125 psf
B2/B8 Industrial and warehousing	£90 psf

#### Construction Costs - Refurbished

B1a Office	£105-£116 psf
B1c Workshop	£50-£75 psf
B2/B8 Industrial and warehousing	£53-£59 psf

\* cost manually adjusted to £171 psf at the request of OPDC therefore not attributable to C&W;). Origin Business Park space at £68 psf due to nature of likely spec and structure

# Contact

AJ100 Practice of the Year 2016  
Winner

London\  
159 St John Street  
EC1V 4QJ  
+44 (0)20 7336 8030  
[mail@hawkinsbrown.com](mailto:mail@hawkinsbrown.com)

Manchester\  
3C Tariff Street  
M1 2FF  
+44 (0)161 641 5522  
[mail@hawkinsbrown.com](mailto:mail@hawkinsbrown.com)

[hawkinsbrown.com](http://hawkinsbrown.com)